

L'Ufficio
The Office
ザ・オフィス
办公空间



L'Ufficio
The Office
ザ・オフィス
办公空间

The Office Index

SISTEMI DIREZIONALI C.E.O. OFFICE FURNITURE エグゼクティブシステムズ 扶椅办公室

- 010 Jobs
→ Rodolfo Dordoni
- 070 C.E.O. Cube
→ Lella and Massimo Vignelli
- 104 H_0
→ Claudio Silvestrin
- 132 Corinthia
→ Luca Scacchetti

PELLE FRAU® PELLE FRAU® LEATHER PELLE FRAU® ペッレフラウ® PELLE FRAU® 皮革

- 230 Pelle Frau®
→ Color System Frau®
- 232 Pelle Frau®
→ Saddle

POLTRONE UFFICIO OFFICE ARMCHAIRS オフィス用アームチェア 领导体系

- 154 DownTown
→ Jean-Marie Massaud
- 162 Ginger Ale Office
→ Roberto Lazzeroni
- 170 Chancellor
→ Lievore - Altherr - Molina
- 178 Forum
→ Poltrona Frau R. & D.
- 186 Brief
→ Emilio Ambasz
- 194 Oxford
→ Poltrona Frau R. & D.

POLTRONE CONFERENZA CONFERENCE ARMCHAIRS 会議場用アームチェア 会议扶手椅

- 202 THF
→ Tito Agnoli
- 206 Movie
→ Mario Marengo
- 210 Ring
→ Langranja
- 214 Ego
→ Pininfarina
- 218 Onda
→ Lella and Massimo Vignelli
- 222 Chancellor Conference
→ Lievore - Altherr - Molina
- 226 Forum Bridge
→ Poltrona Frau R. & D.

The Poltrona Frau Office

L'UFFICIO COME RACCONTO ABITATIVO

L'articolata collezione di Poltrona Frau trova espressione in numerosi cataloghi, diversi per contenuto tipologico ma omogenei nella filosofia. Tutto muove dalla volontà di creare ambienti raffinati e confortevoli in cui l'essere umano possa vivere piacevolmente i diversi momenti della giornata. La matrice originaria della visione di Poltrona Frau è senz'altro da individuare nell'ambiente domestico e, più precisamente, in una sofisticata idea di comfort secondo la quale le scelte materiche e di dettaglio sono in grado di condurre ciascun abitante in una dimensione rigorosa ed esclusiva. Infatti, seguendo la grande tradizione italiana del saper fare, Poltrona Frau è certa che la nobiltà dei materiali impiegati e l'accuratezza delle procedure realizzative si ponga di per sé come garanzia per la nobiltà del risultato compositivo finale. Chi si sia abituato, stando seduto in un'invitante poltrona o sdraiato su un confortevole divano, al quel tipo di ineguagliabili sensazioni tattili e percettive offerte da Poltrona Frau difficilmente potrà accettare, una volta giunto nel suo ambiente di lavoro, un livello di "ospitalità" inferiore. Per questo, quasi spontaneamente, nel corso di oltre 100 anni di storia è nato "L'Ufficio" di Poltrona Frau. La stessa morbida accoglienza, la stessa perfetta definizione dei dettagli, la stessa matericità che declina pelli sceltissime abbinandole a preziose essenze lignee, a metalli dalle finiture ricercate e a preziosi marmi e pietre e inoltre una gamma di finiture e abbinamenti talmente ampia da garantire una personalizzazione praticamente infinita, consentono di far transitare chi è abituato alla unicità della casa Poltrona Frau in un ambiente ufficio assolutamente adeguato e altrettanto unico. Il sapiente uso della Pelle Frau® in particolare, da sempre garanzia di qualità e durata, introduce nei sistemi direzionali una caratteristica veramente rara nel mondo dell'ufficio.

THE OFFICE AS A HOUSING TALE

The highly diversified Poltrona Frau collection is divided into a large number of catalogues, different in content yet all sharing the same philosophy. Their underlying common denominator is a desire to create elegant and comfortable rooms that can be enjoyed at any time of day. The roots of the Poltrona Frau vision are to be found in the home and, more specifically, in a sophisticated idea of comfort where the choice of material and detail takes users into an exclusive, discerning dimension. True to the great tradition of Italian savoir-faire, Poltrona Frau is certain that the excellence of its materials and precision of its production processes guarantee the excellence of the final effect. Anyone accustomed to the unparalleled tactile and perceptual qualities offered by Poltrona Frau when sitting in a cosy armchair or lying on a comfortable sofa, will find it difficult to accept a lower level of "hospitality" at work. This is why Poltrona Frau "Office" emerged almost spontaneously during the company's 100 years plus of history. People used to the uniqueness of a Poltrona Frau home can in this way enjoy the same total satisfaction and uniqueness in the workplace, with the same comfort, the same perfect definition of details, and the same material aspect that combines carefully selected leathers with fine woods or metals in sophisticated finishes or precious marble and stone, plus a range of finishes and combinations diverse enough to guarantee practically infinite customisation. Skilful use of Pelle Frau® leather in particular, always a guarantee of quality and durability, introduces into management systems a feature that is truly rare in the office environment.

ザ・オフィスはライフ・スタイルの表現

ポルトローナ・フラウは多岐に亘るコレクションのカタログを家具の分野別にご用意していますが、基本となるフィロソフィーは一貫しています。日々の暮らしの中のどの時間帯でも、快適にお過ごしいただけるよう、洗練された心地よい環境を生み出す事を目指しているのです。高級で、精度の高いお住まいを造り出すために素材を厳選し、ディティールにこだわって、高性能のコンフォートを提供するポルトローナ・フラウの住環境にその根本となる精神が見てとれます。イタリアの家具作りの比類無き伝統を踏襲するポルトローナ・フラウは使用する素材の質の高さ、作りの丁寧さこそが製品のハイグレードな仕上がりを約束すると確信しております。ご自宅でポルトローナ・フラウのアームチェア、シェーズロング、ソファアの掛け心地や肌触りの良さに慣れしまうと、職場でレベルの低い“住環境”を受け入れるのは難しいものです。自然な流れとして、100年を超える歴史を経た今、ポルトローナ・フラウから“L'Ufficio” ザ・オフィスのコレクションが誕生しました。他のコレクションと同様に快適な掛け心地、細部の完成度の高さ、上質な素材をお約束し、厳選されたレザー、質の高いメタル類による高級仕上げ、高貴な大理石や石材を組み合わせる事により、高級感溢れるすっきりとしたラインを描きだします。仕上げや組合せの選択肢は非常に幅広く、カスタマイズの楽しみは限り無く広がります。ご自宅でポルトローナ・フラウの比類無い住環境に慣れた方に、オフィスでもその素晴らしい環境を再現していただけるのです。特に、Pelle Frau® ベッレ・フラウ® を使用した革張りは質の高さと耐久性をお約束し、エグゼクティブのオフィスに類を見ない風格を醸し出します。

办公家居之选

Poltrona Frau 高度多元化,不同的产品目录介绍了不同的功能,并共享相同的品牌理念。那就是,创造一个完美的空间,给使用者无论何时都能享受优雅和舒适。Poltrona Frau 的办公家具精髓得益于对家用家具炉火纯青的诠释,对舒适高雅的极致追求使其非常挑剔用料和细节。Poltrona Frau 坚信,真正的意大利处世哲学,卓越的表达不外乎其对材料和生产工艺的精益求精。任何已经习惯于 Poltrona Frau 家用家具无与伦比的舒适坐感和品质的人都会很难接受在工作中有不一致的办公体验。Poltrona Frau 是成功人士之选,在品牌 100 多年的发展历程中于 90 年代开发出办公系列家具。朝九晚五的办公室生活,由于 Poltrona Frau 的细致体贴使上班变得具有满足感;与起居生活一样同样完美的细节,是通过精心挑选的皮革,精致的木材,简约的结构,珍贵的大理石台面,以及一系列细节装饰来表达的,体现高级定制的无限可能。Poltrona Frau 将炉火纯青的 Pelle Frau® 皮革娴熟运用于高级经理人办公系列,将最高品质的皮革沿用至办公体验,给予职场精英无微不至的关怀。

L'UFFICIO COME OPERA APERTA

Disegnati da alcuni tra i più celebri architetti contemporanei, gli arredi per l'ufficio Poltrona Frau prevedono, ovviamente, le predisposizioni tecnologiche più avanzate, senza tuttavia esaltare questa componente in chiave progettuale, ovvero senza trasformare, come sovente avviene nell'ambiente lavorativo, gli arredi stessi in fredde attrezzature. Le scrivanie, le cassettiere, i mobili, le sedute di Poltrona Frau risolvono quindi qualsiasi problema prestazionale continuando tuttavia a restituire un'immagine raffinata e minimale, silenziosa e curata. Ne deriva il ritratto ideale dell'ambiente di lavoro Poltrona Frau: un ambiente ove le parole chiave sono sicurezza ed equilibrio, ove l'innovazione non dimentica la tradizione e l'essere umano resta sempre al centro, con le sue specificità e le sue differenze. Proprio per rispettare ogni singola esigenza, "L'Ufficio" Poltrona Frau è in realtà modificabile a partire da alcune situazioni base: per giungere, secondo i principi più aggiornati del furniture design, a considerare questo stesso catalogo una sorta di "opera aperta", profondamente customizzabile.

THE OFFICE AS AN OPEN PLAY

Designed by some of the most famous contemporary architects, Poltrona Frau office furnishings obviously include state of the art technology, which never dominates the design, in other words without turning the furniture into the soulless equipment we often find in the workplace. Poltrona Frau's desks, chests of drawers, units and seating solutions thus meet all performance requirements, while still however elegant, minimal, understated and meticulously detailed. The result is the ideal Poltrona Frau workplace: an environment whose watchwords are safety and balance, where innovation also encompasses tradition, always focussed on people and their distinguishing traits and differences. Poltrona Frau "The Office" is actually a series of basic pieces that can be modified to meet any individual need. Indeed, following the most up-to-date principles in furniture design, we could say that this catalogue is best defined as "work in progress" with great potential for customisation.

ザ・オフィスは完成を待つ製品

デザインを手がけたのは高名な現代建築家数名。言うまでも無く、ポルトローナ・フラウのオフィス家具には先進テクノロジーが搭載されていますが、デザイン上それが強調される事は無いので、オフィスに有り勝ちな味気無い家具にはなりません。ポルトローナ・フラウのデスク、引き出し、キャビネット、チェアは機能面のあらゆる問題を解決すると同時に、洗練されたミニマルなイメージ、落ち着きと品格を感じさせます。ポルトローナ・フラウが目指すオフィス環境のキーワードは、信頼性とバランス、即ち、伝統をなおざりにする事の無いイノベーションであり、あくまでも人間本位、個性や個人差を尊重します。人それぞれのニーズに対応するために、ポルトローナ・フラウの“L'Ufficio”ザ・オフィスはかなりの変更が可能です。現代のファニチャー・デザインに則り、存分にカスタマイズしていただける選択肢をご用意いたしておりますので、このカタログは言うなれば“完成を待つ製品”としてご覧下さいませ。

办公家具革新之路

同 Poltrona Frau 的其他系列一样，办公系列也与当代最著名的建筑师们合作，设计于先进的技术永远是占主导地位的。Poltrona Frau 的书桌，抽屉，单位和座椅解决方案满足所有功能性要求，同时具有高雅，低调，细致的审美体验。Poltrona Frau 理想的办公环境是安全和平衡的，简约的设计使得单品可以随意组合以满足定制空间。按照国际家具设计的最新原则，我们认为，此产品目录最好地定义了“循序渐进的工作”以及定制办公空间的巨大潜力。

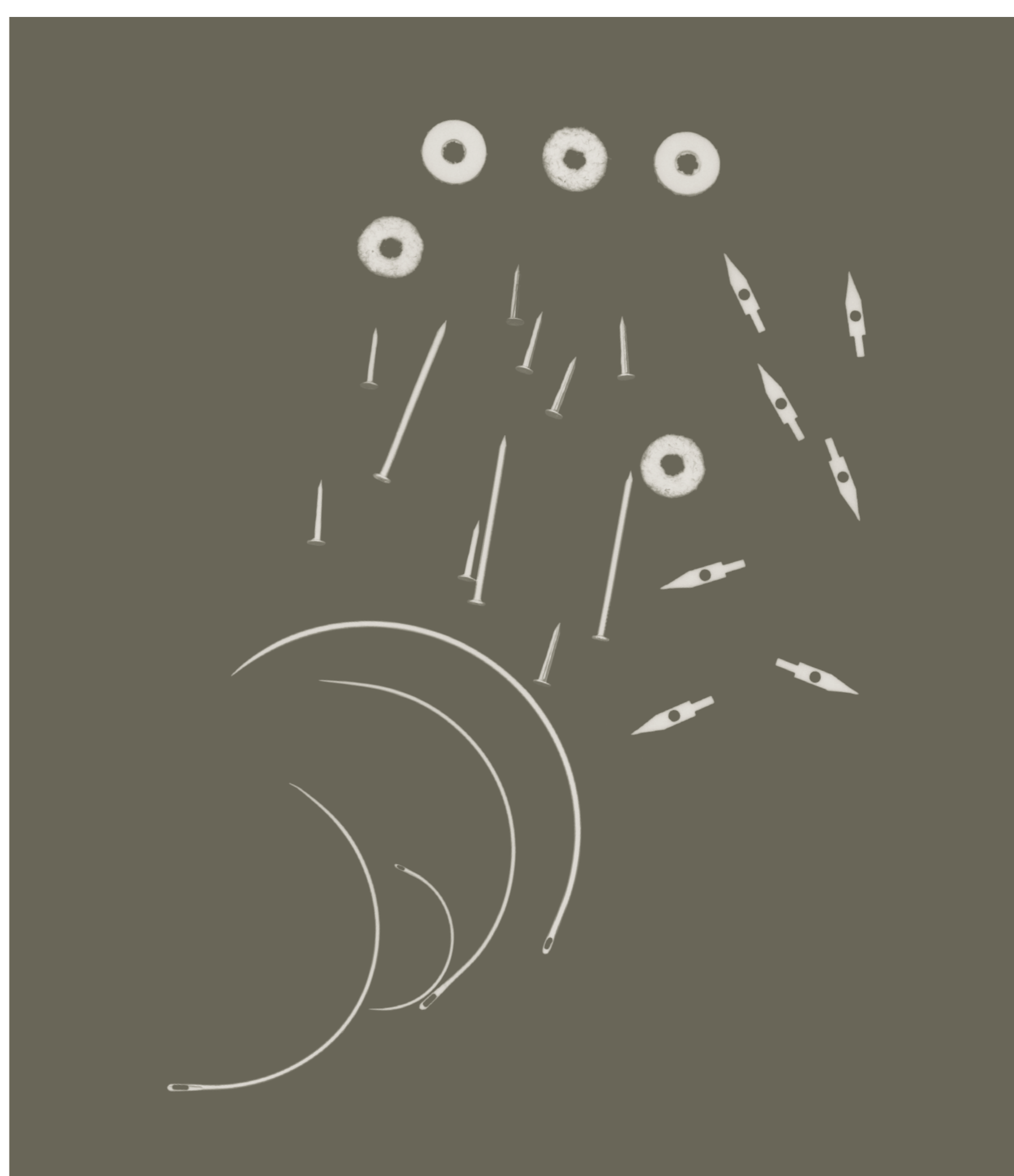

Rodolfo Dordoni

Jobs



RODOLFO DORDONI

Architetto e Designer, nasce e si laurea a Milano. Responsabile nel corso degli anni della direzione artistica di prestigiosi brand del design, disegna prodotti per numerose aziende. Dordoni Architetti, studio fondato a Milano da Rodolfo Dordoni, Luca Zaniboni e Alessandro Acerbi, opera nel campo dell'architettura e dell'interior design in ambito residenziale, commerciale ed allestitivo, sviluppando progetti di ville e abitazioni private, spazi industriali e commerciali curando la realizzazione di showrooms, stand espositivi, ristoranti, hotels.

CONCEPT

Jobs esprime in se e nel suo nome l'atto conclusivo di un percorso progettuale innovativo. Il nuovo sistema d'arredo direzionale nasce da un'attenta riflessione sull'evoluzione dei comportamenti in relazione alle nuove tecnologie e da un'accurata selezione dei materiali: pelle, legni lucidi ed opachi e strutture in metallo spazzolato arricchiscono in tono sobrio ed essenziale i differenti volumi e determinano nuove aree di lavoro.

ロドルフォ・ドルドーニ

建築家・デザイナー。ミラノ生まれ、同地で大学卒業。一流デザインブランドのアートディレクションの責任者として、多数の企業向けにデザインを手掛ける。Rodolfo Dordoni、Luca Zaniboni ルカ・ザニボーニ）、Alessandro Acerbi（アレッサンドロ・アチェルビ）がミラノに開いた建築事務所、Dordoni Architetti（ドルドーニ・アルキテッティ）は、住居、商業、展示に関連する建築・インテリアデザインの分野で活動。個人の邸宅や住宅、商業

施設や産業施設のプロジェクトを実現する一方、ショールーム、展示会のスタンド、レストラン、ホテルなどの企画も手掛けている。

コンセプト

Jobs はそれ自身、そしてその名前自体に、革新的で計画的な工程を踏むという明確な行為を表現しています。新たなエグゼクティブシステムは、新しいテクノロジーとの関係の中で起こる行動の変化についての慎重な観察と、注意深い素材の選択から生まれました。レザー、ポリッシュ加工とマット加工の木材、ブラッシュドメタル構造が、控えめに本質的なトーンの中にも多様なボリュームを生み出し新しい仕事の領域を切り開いています。

RODOLFO DORDONI

Architect and designer, Rodolfo Dordoni was born in Milan where He graduated. Responsible over the years for the art direction of numerous prestigious design brands, he has worked for many companies. Dordoni Architetti, a studio founded in Milan by Rodolfo Dordoni, Luca Zaniboni and Alessandro Acerbi, works in the field of architectural planning and interior design in the residential, commercial and exhibition areas, designing projects for private houses and villas, industrial and commercial spaces, and overseeing the realisation of showrooms, exhibition stands, restaurants, and hotels.

CONCEPT

Jobs expresses in itself and its name the final act of an innovative design path. The new managerial system has been created through careful reflection on the evolution of behaviours in relationship to new technologies and through the careful selection of materials. Leather, polished and matte woods and brushed metal structures give a sober and essential feel to the different volumes and determine new work areas.

罗多尔夫·多尔多尼

建筑师及设计师，他出生于米兰，毕业于米兰理工大学建筑专业，多年来为很多知名设计品牌担任艺术指导。多尔多尼建筑事务所由罗多尔夫·多尔多尼、卢卡·扎尼波尼 Luca Zaniboni 和阿雷桑德罗·阿切尔比 Alessandro Acerbi 创建于米兰，主要从事住宅、商业及展览领域内的室内设计及建筑业务，同时负责私人住宅和别墅，工商业空间的项目设计，监督展厅，展馆，餐厅以及酒店等项目的实施完成。

理念

Jobs 系列以其命名表达了其在创新性设计领域之路的探索。通过仔细反思人类行为的进化关系和对材质的精挑细选，创造出了新的管理系统。通过对不同体积产品之上皮革，亮光饰面，哑光饰面以及拉丝金属结构的运用，创造出全新的一种理性却不可或缺的一种感觉。









↑ Jobs Executive Desk with meeting area — meeting area ↗ Open shelving



Sistemi Direzionali — Jobs

C.E.O. Office Furniture — Jobs

エグゼクティブシステムズ — Jobs

蟹 梅様 滝 鎌 任 所 — Jobs



↑ Jobs Meeting Table 485×150 cm + Cabinet 230×52 cm, Pelle Frau® SC 28 Seppia / Lead Oakwood

Sistemi Direzionali — Jobs

C.E.O. Office Furniture — Jobs

エグゼクティブシステムズ — Jobs

蟹 樽 様 准 鎌 任 所 — Jobs

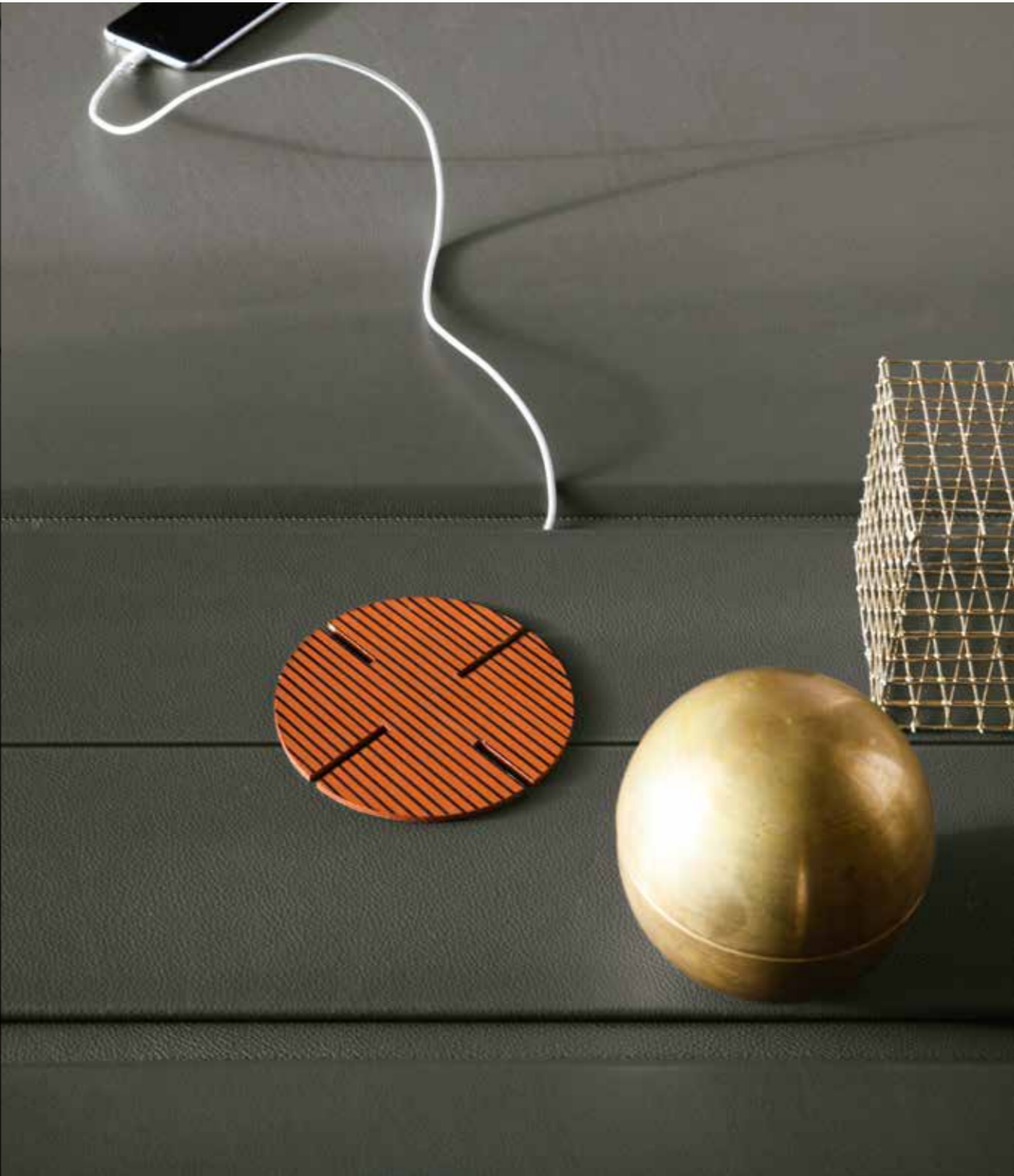

↑ Jobs Meeting Table 485×150 cm with President area — President area ↗ Hardware with central doors

Sistemi Direzionali — Jobs

C.E.O. Office Furniture — Jobs

エグゼクティブシステムズ — Jobs

監 柵様 濶 鑲 仟 仞 — Jobs





↑ Jobs Bookcase 177×182 cm + Bookcase 177×182 cm — Shelves details ↗ Harmony of materials: leather, polished and matte surfaces

Sistemi Direzionali — Jobs

C.E.O. Office Furniture — Jobs

エグゼクティブシステムズ — Jobs

蟹 梅様 濰 鎌 仟 仞 — Jobs



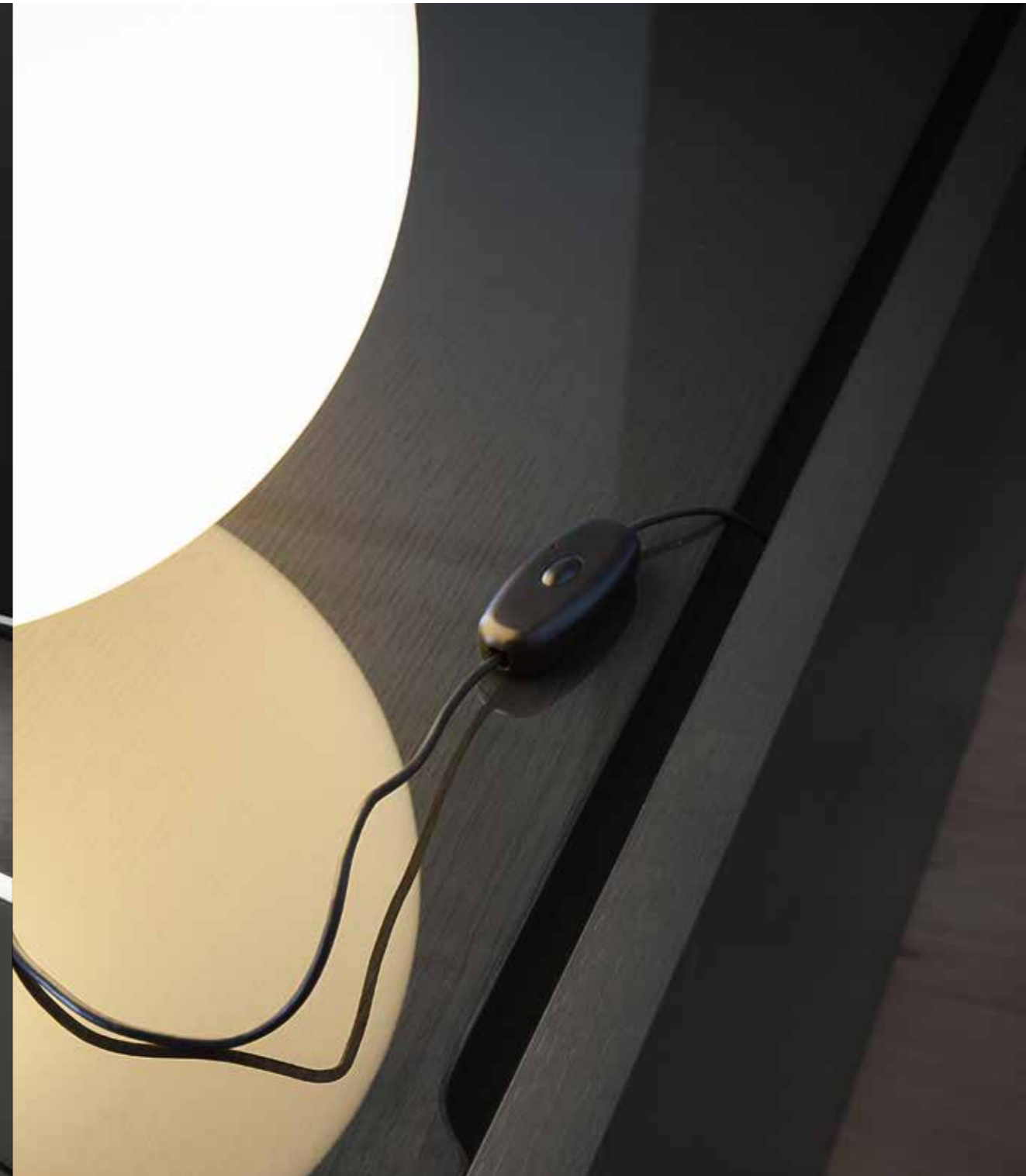

↑ Jobs Cabinet 230×52 cm — File drawers ↗ Backside folding door for cables management. Top in a polished finish

Jobs Materials

Armonia di materiali: pelle, rovere, acciaio.

Alternanza di superfici lucide e opache. Una combinazione di texture da applicare sui diversi elementi che compongono il sistema Jobs: strutture portanti, piani, basi, colonne passacavi, montanti, fessure per l'uscita dei cavi, mobili e cassettiere, "Guest area", "Meeting area" e "President area".

ACCIAIO SATINATO VERNICIATO PIOMBO

Acciaio satinato verniciato piombo con caratteristica sezione a "T" per la struttura portante di tavoli e scrivanie e per i montanti delle librerie. Stessa finitura anche per la base dei cabinet.

ROVERE PIOMBO E ROVERE TABACCO

Due differenti colori di rovere, nelle finiture lucido ed opaco. Opaco per la "Guest area" e la "Meeting area" delle Desk e i pannelli laterali della "President Area" dei tavoli, lucido per la colonna passacavi di tavoli e scrivanie e per i divisori delle Bookcase. In Rovere opaco, Piombo o Tabacco, è anche la fascia in legno che corre su tutta la lunghezza del piano delle Desk e dei tavoli che può consentire, grazie ad una fessura nascosta nel legno, l'uscita dei cavi elettrici. Mobili e cassettiere, impiallacciati in Rovere Piombo o Tabacco, abbinano finiture lucide e opache.

PELLE FRAU® COLOR SYSTEM

96 differenti nuance del Color System Frau®. 96 possibili colori di pelle con cui rivestire l'area di lavoro del piano di scrivanie e tavoli e i frontali dei cassetti di cassettiere e cabinet. Anche la "Guest area" delle Desk e la "President area" dei tavoli, a richiesta, possono essere rivestiti in pelle come il resto del piano. Nelle librerie la pelle riveste gli schienali.

L'Ufficio

Harmony of materials: leather, Oakwood and steel. Alternating polished and matte surfaces. A combination of textures to apply to the different elements composing the Jobs system: supporting frames, tops, bases, cable management columns, cable outlet slots, cabinets and chests of drawers, Guest, Meeting and President area.

BRUSHED STEEL WITH A LEAD PAINTED FINISH

Brushed steel with a lead painted finishing with "T" section characteristic for tables and desks' structures and bookcases' pillars. Same finishing for cabinets' bases too.

LEAD OAKWOOD AND TOBACCO OAKWOOD

Two different colours of Oakwood, with polished and matte finishes. Matte for Guest and Meeting Area of the desks and lateral panels of the tables' President Area, and polished for the cable management columns of Tables and Desks and Bookcases' partitions. A matte-finish oak strip in Lead or Tobacco runs the entire length of the top of the Desks and Tables allowing the electric cables exit, thanks to a wood hiding crack. Cabinets and chests of drawers are oak veneered in Lead or Tobacco with glossy and matte finishes.

PELLE FRAU® COLOR SYSTEM

Color System Frau® offers 96 different shades. 96 possible leather colours for upholstering desks and tables' work Tops and drawers and cabinets' fronts. On request, the Desk's "Guest area" and the Table's "President Area" can be also upholstered in leather like the rest of the top. In the Bookcases the leather upholsters the backsides.

The Office

素材の調和: レザー、オーク、スチールポリッシュ加工とマット加工の組み合わせ Jobs システムを構成する複数の要素として採用されるテクスチャーのコンビネーション: 耐力構造、天板、台、ケーブルモール、支柱、ケーブル用の溝、家具や引き出し、「ゲストエリア」、「ミーティングエリア」及び「プレジデントエリア」

鉛色のサテン仕上げスチール

デスク及びテーブル、本棚、キャビネットの台の支柱の構造は、断面が特徴的な“T”構造。

鉛色オークと黄褐色オーク

オークには2色あり、ポリッシュ加工もしくはマット加工が施されています。マット加工はデスクの「ゲストエリア」と「ミーティングエリア」並びに、テーブルの「プレジデントエリア」のサイド・パネルに使われ、ポリッシュ加工はテーブルとデスクのケーブルモール及びブックケースの仕切りに使用。デスクやテーブルの作業台の長さにあわせた木製の平縁は、鉛色もしくは黄褐色のマット仕上げオークで、木材の内に隠してある溝を通して電気配線を取ることが可能です。家具とキャビネットは鉛色もしくは黄褐色のオークで化粧張りされ、ポリッシュ加工もしくはマット加工が施されます。

PELLE FRAU® COLOR SYSTEM ペツラフのカラーシステム

Color System Frau® のカラーシステム(レザー)の 96 種類の異なるユアンス。デスクやテーブルの天板部の作業台や、チェストとキャビネットの引き出しの正面部分を覆うレザーの色に 96 つの可能な選択肢があります。デスクの「ゲストエリア」及びテーブルの「プレジデントエリア」、リクエストがあれば、卓上の他の部分と同じレザーにすることが可能。本棚は背板部がレザー張り。

ザ・オフィス

和质的材料: 皮革、栎木、钢材。光滑与哑光表面交替。各种质地的组合应用于组成 Jobs 系统的不同元素之上: 承重结构、平面、底座、走线柱、框架、出线槽、家具及抽屉柜、“宾客区”、“会议区”和“总裁区”。

鉛色漆轧光钢材

鉛色漆轧光钢材，“T”字截面独具特色，用于桌子和写字台的支撑结构，以及书架的框架。橱柜的底座采用同样的表面处理。

鉛色栎木和烟草色栎木

两种不同颜色的栎木，有光亮和哑光两种表面效果。哑光的用于 Desk 的“宾客区”和“会议区”，以及桌子的“总裁区”；而光亮的则用于桌子和写字台的走线柱，以及书柜的隔板。一个哑光栎木条，铅色或烟草色，贯穿了 Desk 和桌子台面的整个长度，利用隐藏在木板中的细槽，用来将电线引出。家具和抽屉也采用的铅色或烟草色的栎木镶板，并配有光亮和哑光的表面效果。

PELLE FRAU® COLOR SYSTEM 皮革色系

Color System Frau® 拥有 96 种色调。96 种颜色的皮革可用于装饰写字台和桌子台面的工作区，以及抽屉、抽屉柜和橱柜的面板。根据需要，Desk 的“宾客区”和桌子的“总裁区”也可如台面的其余部分以皮革装饰。在书架上，皮革可用于装饰后部衬板。

办公空间



Sistemi Direzionali — Jobs

C.E.O. Office Furniture — Jobs

エグゼクティブシステムズ — Jobs

監 柵様濰 鑲任仟 — Jobs

Jobs President Desk

Piano e "Guest area" in Pelle Frau® SC 28 Seppia. Mobile in Rovere Piombo.

Top and "Guest area" in Pelle Frau® leather SC 28 Seppia. Lead Oak Cabinet.

Pelle Frau® SC 28 Seppia (ベッレフラウ® SC 28 セビア)の作業台と"Guest area" (ゲストエリア)。Piombo (鉛色)のオーク製家具。

桌子台面和会客区块采用 Pelle Frau® SC 28 Seppia 皮革,柜体采用铅色橡木饰面。

Piano in Pelle Frau® SC 28 Seppia. "Guest area" e mobile in Rovere Piombo.

Top in Pelle Frau® leather SC 28 Seppia. "Guest area" and cabinet in Lead Oakwood.

Pelle Frau® SC 28 Seppia (ベッレフラウ® SC 28 セビア)の作業台。Piombo のオーク製 "Guest area" と引き出しの筐体。

桌子台面采用 Pelle Frau® SC 28 Seppia 皮革, 会客区块和柜体采用橡木。

Il mobile può essere montato a destra o a sinistra della scrivania rispetto alla posizione del fruitore determinandone il verso.

The cabinet can be assembled to the right or left of the desk, based on the user's preference

引き出しの筐体は、利用者の位置から見てデスクの左右どちらかに方向を決めて設置します

柜体可以根据客户需求组装在左侧和右侧。



Jobs President Desk Large

Piano e "Guest area" in Pelle Frau® SC 28 Seppia. Mobile in Rovere Piombo.

Top and "Guest area" in Pelle Frau® leather SC 28 Seppia. Lead Oakwood Cabinet.

Pelle Frau® SC 28 Seppia (ベッレフラウ® SC 28 セビア)の作業台と"Guest area" (ゲストエリア)。Piombo (鉛色)のオーク製引き出しの筐体。

桌子台面和会客区块采用 Pelle Frau® SC 28 Seppia 皮革,柜体采用铅色橡木饰面。

Piano in Pelle Frau® SC 28 Seppia. "Guest area" e mobile in Rovere Piombo.

Top in Pelle Frau® leather SC 28 Seppia. "Guest area" and cabinet in Lead Oakwood.

Pelle Frau® SC 28 Seppia (ベッレフラウ® SC 28 セビア)の作業台。Piombo のオーク製 "Guest area" と引き出しの筐体。

桌子台面采用 Pelle Frau® SC 28 Seppia 皮革, 会客区块和柜体采用橡木。

Il mobile può essere montato a destra o a sinistra della scrivania rispetto alla posizione del fruitore determinandone il verso.

The cabinet can be assembled to the right or left of the desk, based on the user's preference.

引き出しの筐体は、利用者の位置から見てデスクの左右どちらかに方向を決めて設置します。

柜体可以根据客户需求组装在左侧和右侧。



Jobs Executive Desk Small / Executive Desk

Piano e "Guest area" in Pelle Frau® SC 80 Bruno Havana.

Top and "Guest area" in Pelle Frau® leather SC 80 Bruno Havana.

Pelle Frau® SC 80 Bruno Havana (ペッレフラウ® SC 80 ハバナブラウン)の作業台と"Guest area" (ゲストエリア)。

桌子台面和会客区块采用 Pelle Frau® SC 80 Bruno Havana 皮革,柜体采用铅色橡木饰面。



Piano in Pelle Frau® SC 80 Bruno Havana. "Guest area" in Rovere Tabacco.

Top in Pelle Frau® leather SC 80 Bruno Havana. "Guest area" in Tobacco Oak.

Pelle Frau® SC 80 Bruno Havana (ペッレフラウ® SC 80 ハバナブラウン)の作業台。"Guest area" は Tabacco (黄褐色)のオーク。

桌子台面采用 Pelle Frau® SC 80 Bruno Havana 皮革, 会客区块和柜体采用橡木。



La colonna passacavi è in Rovere Tabacco lucido e può essere montata a destra o a sinistra della scrivania rispetto alla posizione del fruitore.

The cable management column is in polished Tobacco Oakwood and can be assembled to the right or left of the desk in relation to the position of the user.

ケーブルモールはポリッシュ加工を施した Tabacco のオークで、利用者から見てデスクの左右どちらにでも設置できます。

柜体可以根据客户需求组装在左侧和右侧。



Jobs Executive Desk Large

Piano e "Guest area" in Pelle Frau® SC 80 Bruno Havana.

Top and "Guest area" in Pelle Frau® leather SC 80 Bruno Havana.

Pelle Frau® SC 80 Bruno Havana (ペッレフラウ® SC 80 ハバナブラウン)の作業台と"Guest area" (ゲストエリア)。

桌子台面和会客区块采用 Pelle Frau® SC 80 Bruno Havana 皮革,柜体采用铅色橡木饰面。



Piano in Pelle Frau® SC 80 Bruno Havana. "Guest area" in Rovere Tabacco.

Top in Pelle Frau® leather SC 80 Bruno Havana. "Guest area" in Tobacco Oakwood.

Pelle Frau® SC 80 Bruno Havana (ペッレフラウ® SC 80 ハバナブラウン)の作業台。"Guest area" は Tabacco (黄褐色)のオーク。

桌子台面采用 Pelle Frau® SC 80 Bruno Havana 皮革, 会客区块和柜体采用橡木。



La cassettera è sempre posizionata sul lato opposto alla colonna passacavi.

The chest of drawers is always positioned on the opposite side to the cable management column.

引き出しは常にケーブルモールの反対側に設置。

柜体可以根据客户需求组装在左侧和右侧。



Jobs Executive Desk with Meeting Area

Piano e "Guest area" in Pelle Frau® SC 80 Bruno Havana. "Meeting area" in Rovere Tabacco.

Top and "Guest area" in Pelle Frau® leather SC 80 Bruno Havana. "Meeting area" in Tobacco Oakwood.

Pelle Frau® SC 80 Bruno Havana (ペッレフラウ® SC 80 ハバナブラウン) の作業台と "Guest area" ゲストエリア。"Meeting area" (ミーティングエリア) は、Tabacco (黄褐色) のオーク。

桌子台面和会客区块采用 Pelle Frau® SC 80 Bruno Havana 皮革，会议区块采用烟草色橡木饰面。



Jobs Easy Desk with Meeting Area

La "Meeting area" può essere installata esclusivamente sul lato dove è presente la colonna passacavi.

The "Meeting area" can only be installed on the side of the cable management column.

"Meeting area" (ミーティングエリア) はケーブルモール側のみ設置可能。

会议区块只可以安装在电缆管理管道侧面。

La colonna passacavi è in Rovere Tabacco lucido.

The cable management column is in polished Tobacco Oakwood.

ケーブルモールは、ポリッシュ加工を施した Tabacco (黄褐色) のオーク製。

电缆管理管道采用亮光烟草色橡木饰面。



Jobs

Easy Desk Small / Easy Desk

Piano e "Guest area" in Pelle Frau® SC 80 Bruno Havana.

Top and "Guest area" in Pelle Frau® leather SC 80 Bruno Havana.

Pelle Frau® SC 80 Bruno Havana (ペッレフラウ® SC 80 / ヴィバナブラウン)の作業台と"Guest area" (ゲストエリア)。

桌子台面和会客区块采用 Pelle Frau® SC 80 Bruno Havana 皮革。



Piano in Pelle Frau® SC 80 Bruno Havana. "Guest area" in Rovere Tabacco.

Top in Pelle Frau® leather SC 80 Bruno Havana. "Guest area" in Tobacco Oakwood.

Pelle Frau® SC 80 Bruno Havana (ペッレフラウ® SC 80 / ヴィバナブラウン)の作業台。"Guest area" は、Tabacco (黄褐色)のオーク製。

桌子台面采用 Pelle Frau® SC 80 Bruno Havana 皮革，会客区块采用烟草色橡木饰面。



Colonna passacavi in Rovere Tabacco lucido.

The cable management column is in polished Tobacco Oakwood.

ケーブルモールは、ポリッシュ加工を施した Tabacco のオーク製。

电缆管理管道采用亮光烟草色橡木饰面。



Jobs

Easy Desk Large

Piano e "Guest area" in Pelle Frau® SC 80 Bruno Havana.

Top and "Guest area" in Pelle Frau® leather SC 80 Bruno Havana.

Pelle Frau® SC 80 Bruno Havana (ペッレフラウ® SC 80 / ヴィバナブラウン)の作業台と"Guest area" (ゲストエリア)。

桌子台面和会客区块采用 Pelle Frau® SC 80 Bruno Havana 皮革。



Piano in Pelle Frau® SC 80 Bruno Havana. "Guest area" in Rovere Tabacco.

Top in Pelle Frau® leather SC 80 Bruno Havana. "Guest area" in Tobacco Oakwood.

Pelle Frau® SC 80 Bruno Havana (ペッレフラウ® SC 80 / ヴィバナブラウン)の作業台。"Guest area" は、Tabacco (黄褐色)のオーク製。

桌子台面采用 Pelle Frau® SC 80 Bruno Havana 皮革，会客区块采用烟草色橡木饰面。



La colonna passacavi può essere montata a destra o a sinistra della scrivania rispetto alla posizione del fruitore.

The cable management column can be assembled to the right or left of the desk in relation to the position of the user.

ケーブルモールは利用者から見てデスクの左右どちらにでも設置できます。

电缆管理管道可以根据用户需求安装在左边或者右边。





Vano interno al piano di lavoro corredato di vassoio portapenne e equipaggiato centralmente con un dispositivo di elettrificazione da acquistare separatamente.

Inner compartment of the work surface complete with pen tray and equipped with a central electrification device that is purchased separately.

作業台内部の空間には、ペン置き用のトレーが備えられ、中心には別途販売されている電化装置を装備できます。

工作区块的内部隔断可以放置钢笔托盘，安装充电插口，需要单独采购。

Jobs President Desk — Dettaglio tecnico del passaggio cavi — Technical details of the cable passage — ケーブル配線に関する技術的詳細 — 电缆管道的技术细节

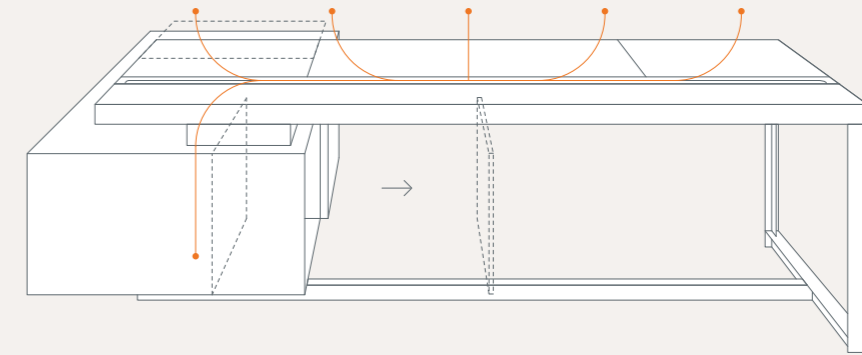

Jobs Executive Desk — Dettaglio tecnico del passaggio cavi — Technical details of the cable passage — ケーブル配線に関する技術的詳細 — 电缆管道的技术细节

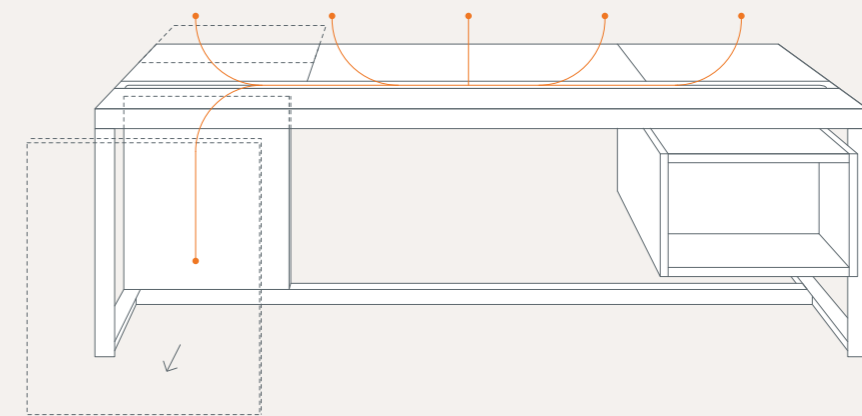

Jobs Modular Meeting Table

Jobs Meeting Table è composto di tre elementi: struttura portante in acciaio satinato verniciato piombo con sezione a "T", piano in Pelle Frau® del Color System e una colonna che cela il passaggio dei cavi elettrici in Rovere con finitura lucida. Il piano in pelle è disponibile con l'area centrale in Rovere, Piombo o Tabacco, con finitura opaca o in Pelle Frau® del Color System.

The Jobs Meeting Table is made up of three elements: a supporting frame in brushed lead-coloured steel with T cross-section, a large top surface in Pelle Frau® leather, and an Oak wooden column with polished finish, which conceals electric cables. The leather top is available with the central part either in Lead Oak or Tobacco Oak veneer with matt finish or covered in Pelle Frau® Color System leather.

Jobs Meeting Table は、3つのエレメントで構成されています。これらのエレメントは、「T」字型セクション付き、リードカラー塗装およびサテン加工されたスチール製の支持構造、Pelle Frau® ベツレ・フラウ® レザー使用の天板、および光沢のあるオーク材使用のケーブル通しが内部にある支柱です。レザー製の天板は、オークかマット加工されたリードカラーおよびタバコカラー、または Pelle Frau® Color System ベツレロフラウ® カラーシステムのバージョンがあります。

Jobs会议桌由三个部分组成：支撑结构采用“T”字截面铅色漆面轧光钢材，台面采用 Color System 的 Pelle Frau® 皮革，一根光亮表面的栎木立柱将电线隐藏其中。皮革台面的中心区域可选配栎木镶板，铅色或烟草色，哑光表面效果，或使用 Color System 的 Pelle Frau® 皮革包裹。



I tavoli da riunione modulari sono disponibili in sette diverse dimensioni che spaziano da 266 cm a 704 cm, tutte attrezzabili a richiesta con President area nelle varianti legno o pelle.

The modular meeting tables are available in seven different sizes ranging from 266 cm to 704 cm. All can be equipped with President area in Oakwood or leather.

モジュラー式の会議用テーブルは、最も小さい 266cm から最大 704cm までの7つの大きさから選ぶことができ、必要に応じて木材、またはレザー使用のプレジデント・エリアを追加することが可能です。

模块化会议桌，从 266cm 到 704cm 共有7种不同尺寸可供选择，所有规格均可根据要求配备木材或皮革的总裁区。

Nelle foto il rivestimento è in Pelle Frau® SC 80 Bruno Havana rispettivamente nelle versioni senza President area e con President area, nelle varianti in Rovere tabacco o Pelle Frau® SC 56 Siena.

In the photos the upholstery is in Pelle Frau® leather SC 80 Bruno Havana in the versions without President area and with President area in Tobacco Oakwood or in Pelle Frau® SC 56 Siena.

写真には Pelle Frau® SC 80 Bruno Havana ベツレ・フラウ® SC 80 ブレーノ・ハバナ、リードカラーのオークバージョンが載っています。最後の写真のタイプには Pelle Frau® SC 56 Siena ベツレ・フラウ® SC 56 シエーナが使用されています。

照片中的款式采用 Pelle Frau® SC 80 Bruno Havana 雪茄色皮革包裹，可配有烟草色栎木或 Pelle Frau® 56 Siena 皮革的总裁区，如最后一张照片所示。

Jobs Modular Meeting Table





La "president area" è prevista, a scelta, in uno dei due lati corti dei Meeting Table. Per questa variante il pannello centrale è rivestito in Pelle Frau® del Color System mentre i due pannelli laterali sono disponibili sia in Rovere con finitura opaca sia rivestiti in Pelle Frau® del Color System. Lo spessore del piano, alle due estremità del tavolo, è rifinito con una cornice incassata in fibra di legno a media densità impiallacciata Rovere Piombo o Rovere Tabacco con finitura opaca.

The Meeting Tables can include a "president area" at one end. In this case, the central panel is covered in Pelle Frau® Color System leather, while the two side panels are available either in Lead Oak or Tobacco Oak veneer MDF with matt finish or covered in Pelle Frau® Color System leather. The two short ends of the table top have recessed edging in Lead Oak or Tobacco Oak veneer MDF with matt finish.

「プレジデント・エリア」は、お好みにより Meeting Table の両サイドのいずれかの部分に追加できます。このバージョンのセンターパネルは、Color System の Pelle Frau® でカバーされ、その反面サイドパネルは、マット加工のオーク材または Color System の Pelle Frau® 使用の 2 つのバージョンからえらべます。テーブルの両サイドのパネルの厚み部分の仕上げは、リードカラーのオーク材で化粧張りされた中密度ウッドファイバー、またはマット加工のタバコカラーのオーク材です。

可选择将会议桌的一个短边设置为“总裁区”。对于此款，中部镶板采用Color System 的 Pelle Frau® 皮革进行包覆，而两个侧板即可配上哑光效果的栎木，也可选用 Color System 的 Pelle Frau® 皮革包覆。桌子台面的两端的厚度方向，采用嵌入到中密度纤维板中铅色或烟草色哑光表面栎木饰板封边。



Jobs

Modular Meeting Table

Con pannelli centrali

With central panels

センター・パネルから

中央面板

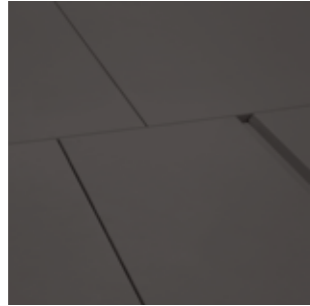

Con pannelli centrali e borchie passacavi

With central panels and cable tidy grommets

センター・パネルと配線用メタル・パーツを通して

带电线收纳管的中央面板



Con sportelli centrali

With central doors

センターの開口部から

可开合中央面板



Sono disponibili 3 versioni Hardware diversamente attrezzabili per il passaggio dei cavi elettrici.

They are available in 3 Hardware versions that can be furnished in different ways to accommodate electrical cables.

ケーブル通しとして異なるコンポーネントで構成できる3つのハードウェアを取り扱っています。

3种五金件版本,用于不同的走线方式设置。



Jobs Meeting Table

Dettaglio tecnico del passaggio cavi - Technical details of the cable passage - Détail technique pour le passage des câbles - Technische Zeichnung der Kabelführung

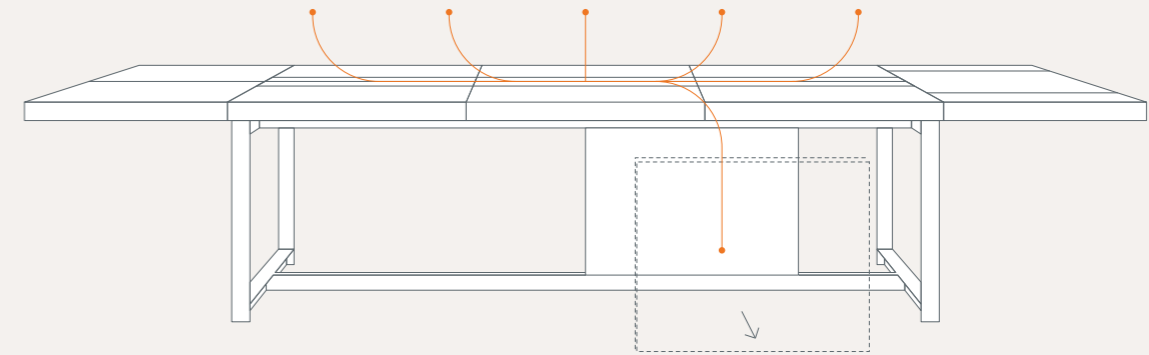



La versione Hardware con pannelli centrali è dotata di un tunnel passacavi di lamiera di metallo traforata e verniciata di colore nero. La versione Hardware con pannelli centrali e passacavi presenta una serie di borchie passacavi in metallo inserite al centro di ciascun pannello centrale e disponibili nella versione verniciata nera. La versione Hardware con sportelli è attrezzata con sportelli che danno accesso ad un vano interno dotato di una borchia passacavi in metallo cromata o verniciata nera.

The Hardware with central panels version is equipped with a cable tidy tunnel in perforated sheet metal and painted black. The Hardware with central panels and cable tidies version has a series of metal cable tidy grommets inserted in the centre of each central panel and available in the version painted black. The Hardware with doors version is equipped with doors that can be used to access an internal compartment equipped with a cable tidy grommet in chrome-plated metal or painted black.

センターパネル付きハードウェア・バージョンは、ブラックカラー塗装加工されたパンチ加工が施された鉄版製のケーブル通しが付いています。センターパネルとケーブル通しつきのハードウェア・バージョンは、各センターパネルの中心部分に、ケーブル通し用のブラックカラー塗装のメタル製飾り紙が取り付けられています。ドアつきハードウェア・バージョンに関しては、ドアから内部にアクセスし、ケーブル通し用のクローム加工、またはブラックカラー塗装のメタル製飾り紙があります。

带有中心镶板的五金件版本，配有金属板制成的走线槽，上有打孔，黑色漆面。带有中心镶板和穿线环的五金件版本，配有一系列的金属穿线环，分布于每块中心镶板的中部，黑色漆面。带有中心盖门的五金件版本，设有盖门，内部配有镀铬或黑漆金属穿线环。

Jobs Bookcase 177×182 cm

Jobs Bookcase è una libreria "Freestanding", bifacciale a configurazione fissa disponibile anche nella variante "Wall" per essere avvicinata alla parete. Nelle foto le librerie sono proposte nella variante Pelle Frau® SC 28 Seppia abbinata al Rovere Piombo, nelle finiture lucida e opaca.

The Jobs Bookcase is a Freestanding, double-sided bookcase with fixed configuration, also available in the "Wall" version to be closer to the wall. In the images libraries are proposed in Pelle Frau® leather SC 28 Seppia combined with Lead Oak, in polished and matte finishes.

Jobs Bookcase は、フリースタンド式の本箱です。固定式であり、両サイドから利用できます。「Wall」バージョンは、壁に近づけることができます。写真は、Pelle Frau® SC 28 Seppia ベッレ・フラウ® SC 28 セビアとリードカラーのオーク(グロス、およびマットタイプ)がペアになっているバージョンです。

Jobs书架是一款独立式书架，双面开放，配有固定装置；也可提供“Wall”款，可贴墙安放。照片中的书架采用了Pelle Frau® SC 28 Seppia 皮革与铅色栎木组合装饰，光亮和哑光表面效果。



Jobs Bookcase 234×145 cm

Elementi divisorii a "T", composti da un pannello verticale in legno laccato lucido e pannello di fondo in Pelle Frau® del Color System, sono disposti sulle mensole con schema irregolare. Montanti a "T" in acciaio satinato verniciato piombo, elementi identificativi della collezione, sono fissati alle estremità della libreria.

"T"-shaped dividing elements made up of a vertical panel in gloss lacquer wood and lower panel in Pelle Frau® leather from the Color System are arranged in an irregular fashion on the shelves. The "T" cross-sections with lead-coloured brushed steel uprights, distinctive features of the collection, are attached to the ends of the bookcase.

「T」字型のディバイダー・エレメントは、グロスラッカー加工が施された垂直パネルとColor SystemのPelle Frau® leather ベッレ・フラウ®レザー使用のパックパネルで構成されています。ディバイダーは、変則的に棚に設置されます。このコレクションの特徴であるリードカラーのスチール製「T」字型支柱は、本箱の先端部分に取り付けられています。

「T」字型隔断由垂直的漆面木饰板和Color System的Pelle Frau®皮革衬板组成，在隔架上不规则分布。该系列的标志性元素「T」字型支撑结构采用铅色漆面轧光钢材，固定在书架的各端。





Gli elementi verticali dei divisori sono in legno multistrato di betulla impiallacciato Rovere Piombo o Rovere Tabacco con finitura lucida disposti perpendicolarmente alla lunghezza dei ripiani e pannelli con rivestimento in Pelle Frau® del Color System disposti parallelamente alla lunghezza dei ripiani. Le mensole con spessore importante sono in Rovere Piombo o Tabacco opaco.

The vertical elements of the dividers are in Rovere Piombo or Rovere Tabacco veneered birch plywood with glossy finish and are perpendicular to the lengths of the shelves and panels upholstered in Pelle Frau® leather from the Color System arranged in parallel to the length of the shelves. Jobs Bookcase has thick shelves in mat Rovere Piombo or Tabacco.

デバイダーの垂直パネルは、グロス加工が施されたリードカラー、またはタバコカラーのオーク材で化粧張りされたカバの木の積層板を使用しています。このタイプのデバイダーは、棚の長さに対し垂直に設置されています。その反面、Color System の Pelle Frau® leather ベッレ・フラウ®レザー使用のパネルは、棚の長さに対し、平行に設置されています。厚みのある棚は、リードカラー、またはタバコカラーのオーク材を使用。

垂直隔板采用桦木胶合板，配以光亮表面的铅色或烟草色栎木饰板，沿层板的整个长度垂直排列；与层板的长度方向平行的，配以 Color System 的 Pelle Frau® 皮革包覆面板。而较厚的架板则为哑光效果的铅色或烟草色栎木饰板。



Jobs

Low Cabinet L284 / L230

Top in Rovere Piombo lucido.

Lead Oakwood top with polished finish.

上部はポリッシュ加工を施した Piombo (鉛色) のオーク製。

桌子台面采用亮光铅色橡木饰面。



Il rivestimento frontale dei cassetti e dell'anta è in Pelle Frau® SC 28 Seppia.

Drawer fronts upholstered in Pelle Frau® leather SC 28 Seppia.

引き出しと扉の上張りは Pelle Frau® SC 28 Seppia (ベッレフラウ® SC 28 セビア) 製。

抽屉面板采用 Pelle Frau® SC 28 Seppia 皮革软包。



Jobs

Drawer Unit

Top in Rovere Piombo opaco.

Lead Oakwood top with matte finish.

上部はマット加工を施した Piombo (鉛色) のオーク製。

桌子台面采用哑光铅色橡木饰面。



Frontali in Pelle Frau® SC 28 Seppia.

Fronts in Pelle Frau® leather SC 28 Seppia.

正面は Pelle Frau® SC 28 Seppia (ベッレフラウ® SC 28 セビア) 製。

前面采用 Pelle Frau® SC 28 Seppia 皮革软包。



La base è verniciata nero testurizzato antigraffio e dotata di 4 ruote piroettanti

The base is painted black with a texturized scratch-resistant finish and has four castors.

台はアンチスクラッチ加工とテクスチャー加工を施したブラックカラーで、4つのキャスター付き。

底座采用黑色纹理防划饰面，带四个脚轮。



Il retro del mobile è dotato di uno sportello ribaltabile che consente l'accesso ad un piccolo vano interno utile alla fuoriuscita dei cavi che, dal pavimento, salgono fino al top attraverso la fessura presente lungo tutta la lunghezza del piano.

The back of the Cabinet is equipped with a folding door that offers access to a small interior compartment. This compartment allows cables, which come up from the floor and reach the top of the desk, to come out through the slot that runs along the entire length of the top.

床からの配線がボード沿いの溝を通してトップまで達するための通り道となる小さな穴を抜けるよう、蓋付の入り口が家具の後ろ側に付いています。

柜子的背后有一面小门通向内部小室，电线等可以从地面穿过小室通到桌面。

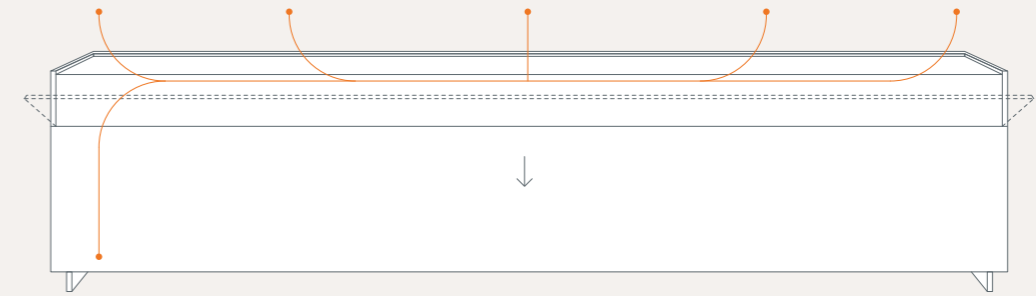

Jobs President Desk — “Guest area” in Pelle Frau® SC leather

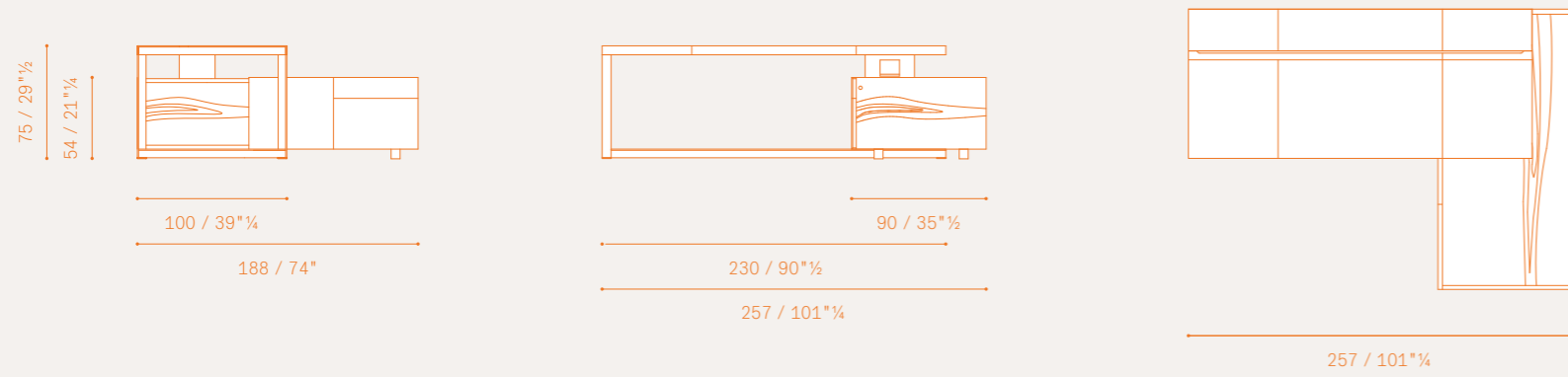

Jobs President Desk — “Guest area” in Oakwood

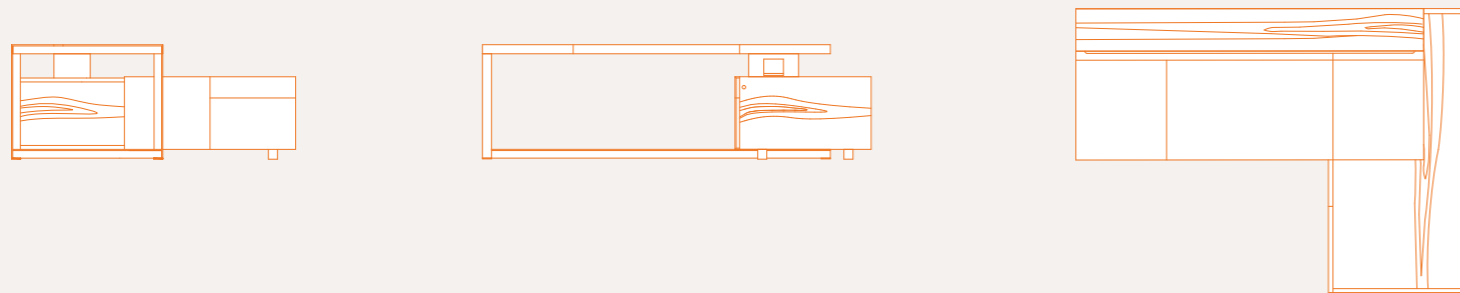

Jobs President Desk Large — “Guest area” in Pelle Frau® SC leather

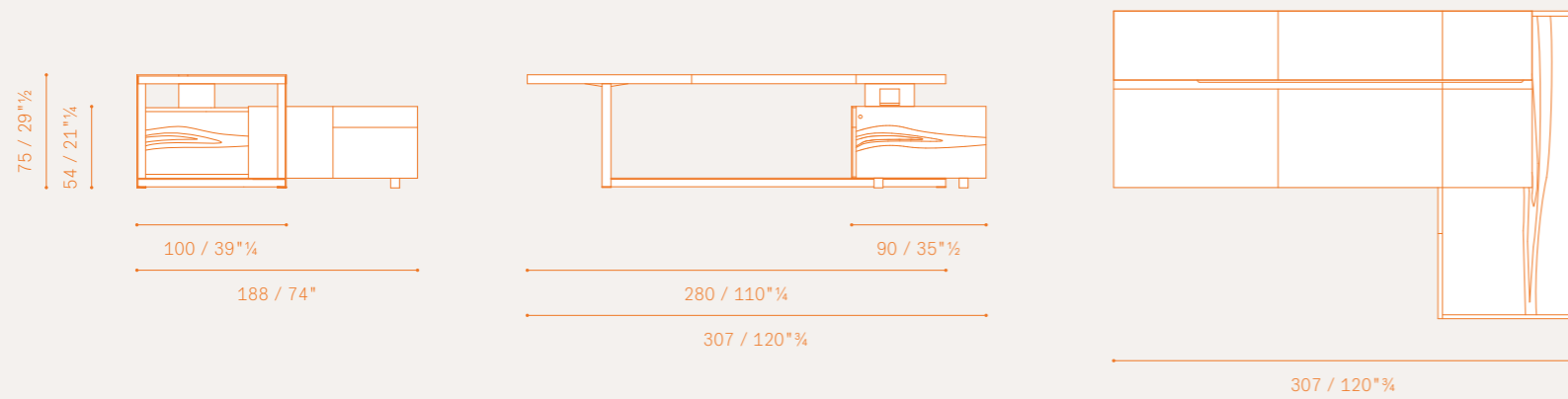

Jobs President Desk Large — “Guest area” in Oakwood

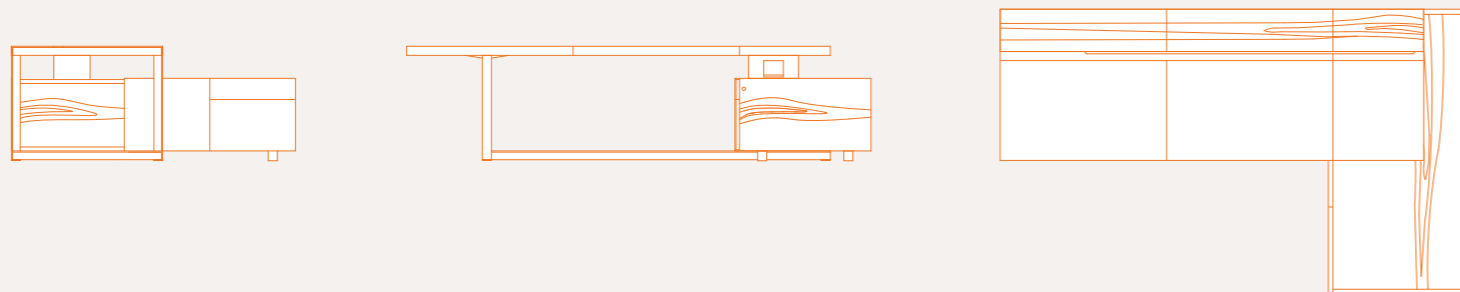

Jobs Executive Desk Small — “Guest area” in Pelle Frau® SC leather

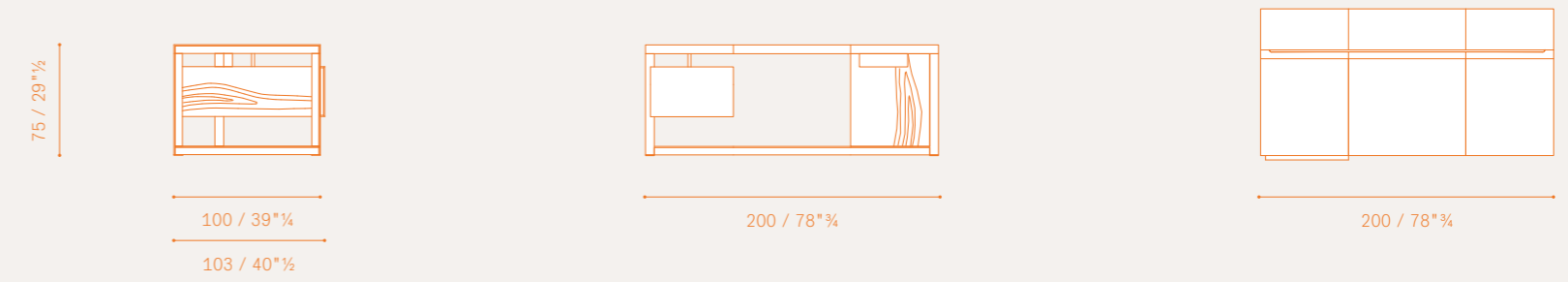

Jobs Executive Desk Small — “Guest area” in Oakwood

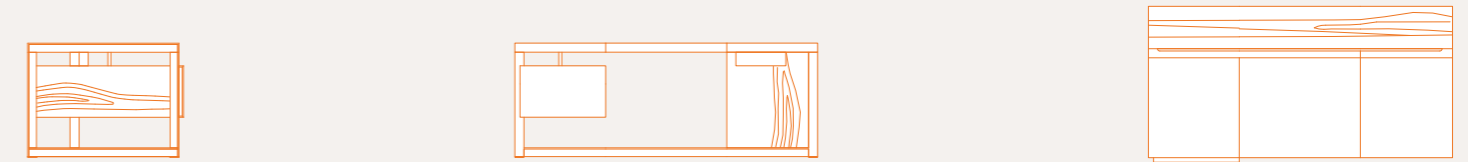

Jobs Executive Desk — “Guest area” in Pelle Frau® SC leather

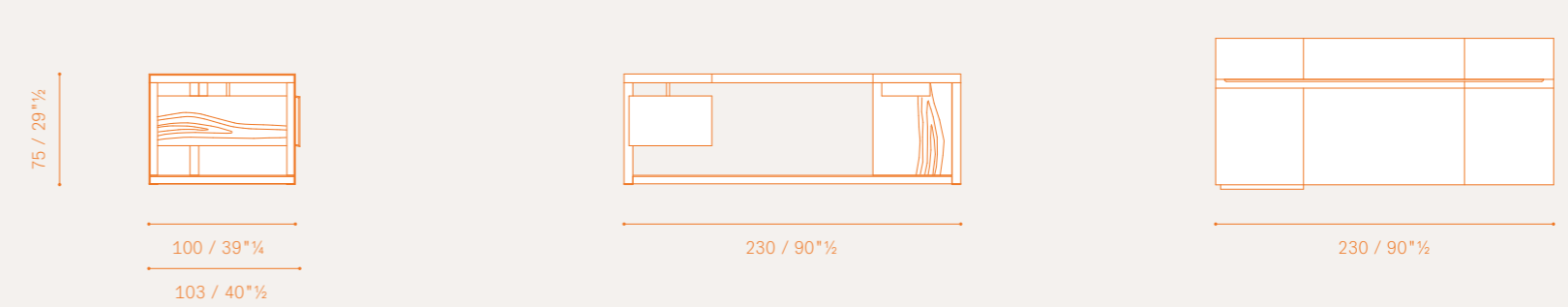

Jobs Executive Desk — “Guest area” in Oakwood

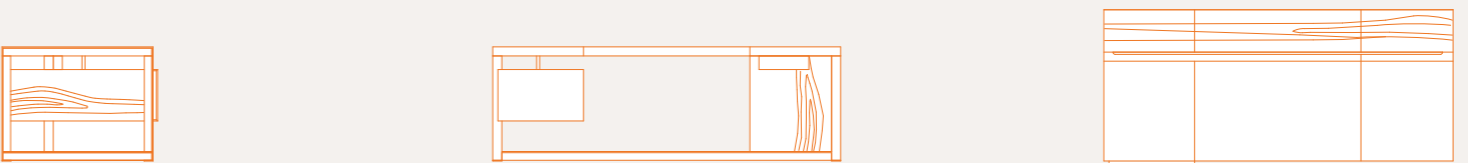

Jobs Executive Desk with "Meeting area" — "Guest area" in Pelle Frau® SC leather

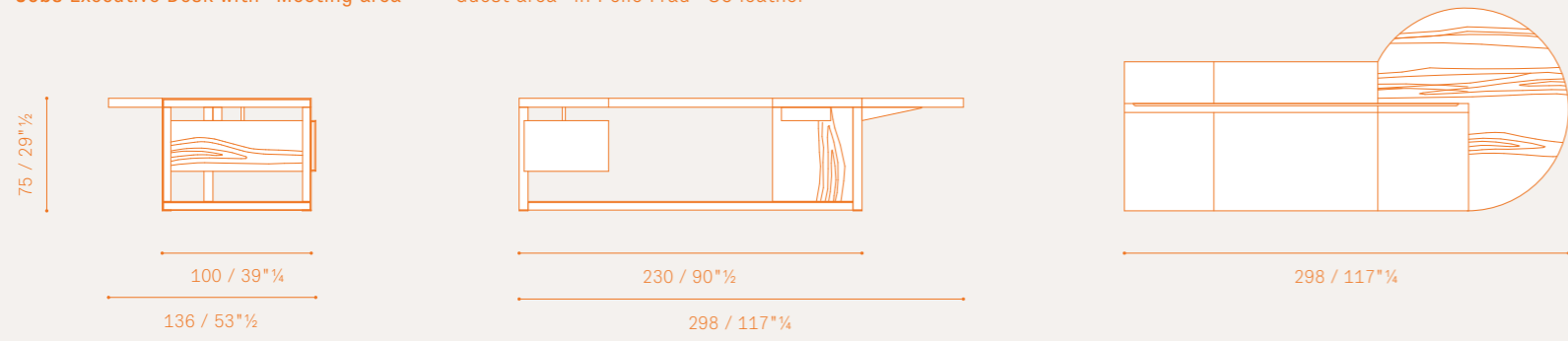

Jobs Executive Desk with "Meeting area" — "Guest area" in Oakwood

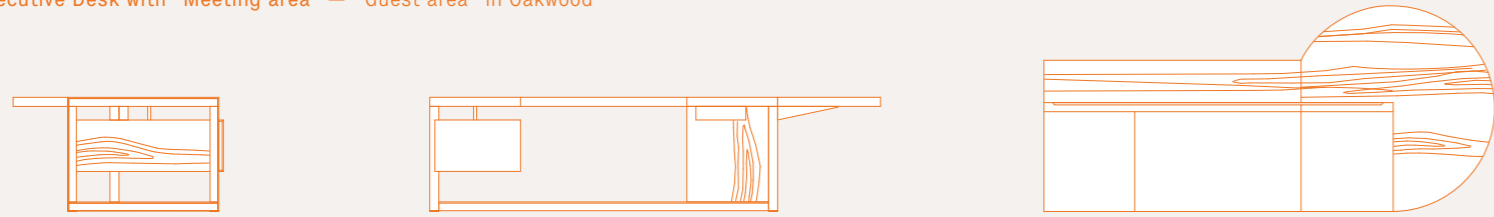

Jobs Easy Desk Small — "Guest area" in Pelle Frau® SC leather

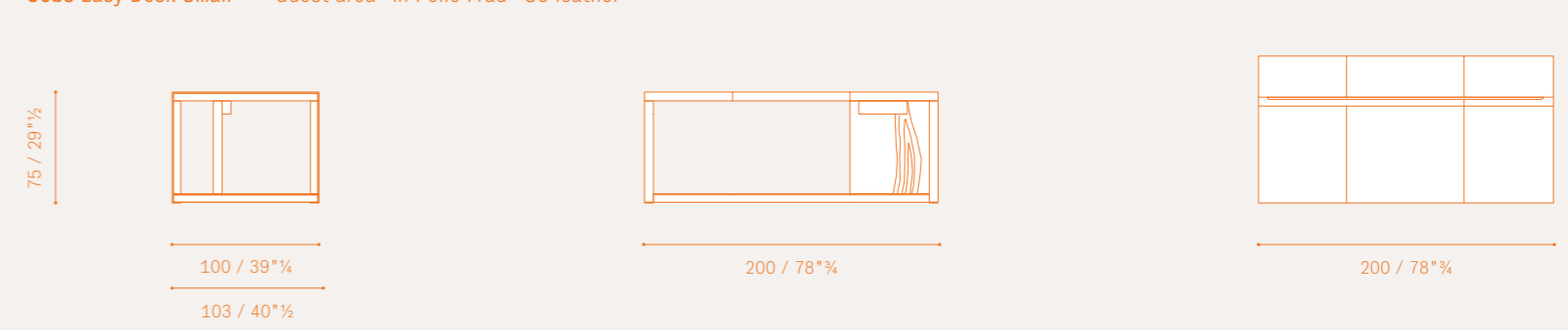

Jobs Easy Desk with Small — "Guest area" in Oakwood

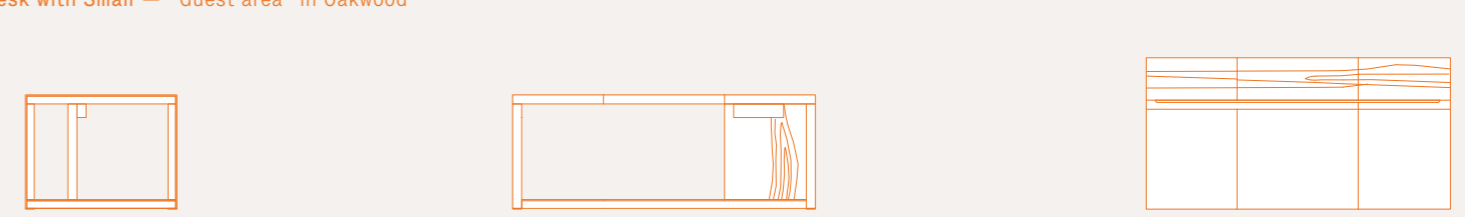

Jobs Executive Desk Large — "Guest area" in Pelle Frau® SC leather

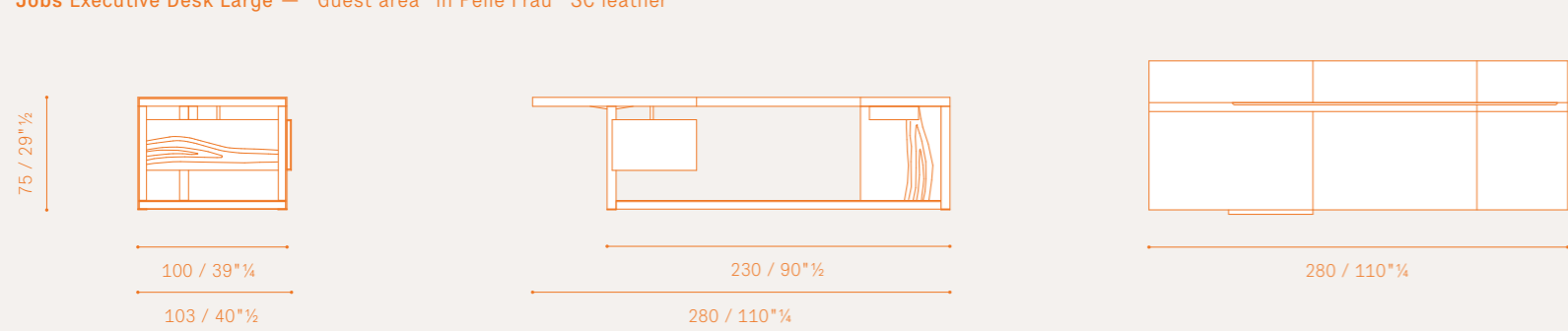

Jobs Executive Desk Large — "Guest area" in Oakwood



Jobs Easy Desk — "Guest area" in Pelle Frau® SC leather

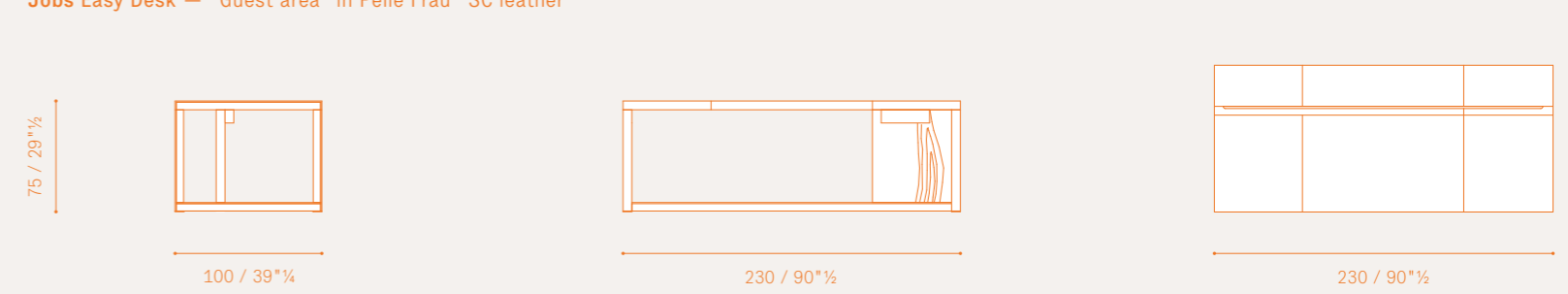

Jobs Easy Desk — "Guest area" in Oakwood

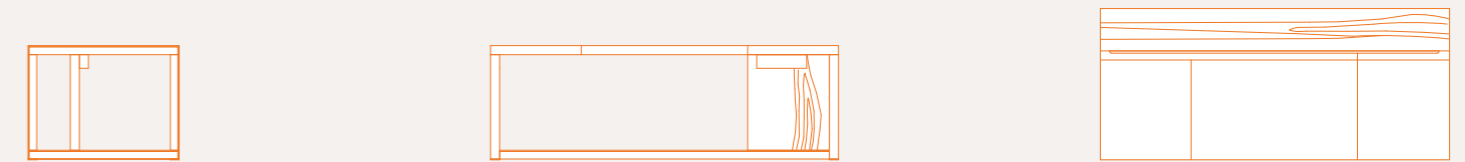

Jobs Easy Desk with "Meeting area" — "Guest area" in Pelle Frau® SC leather

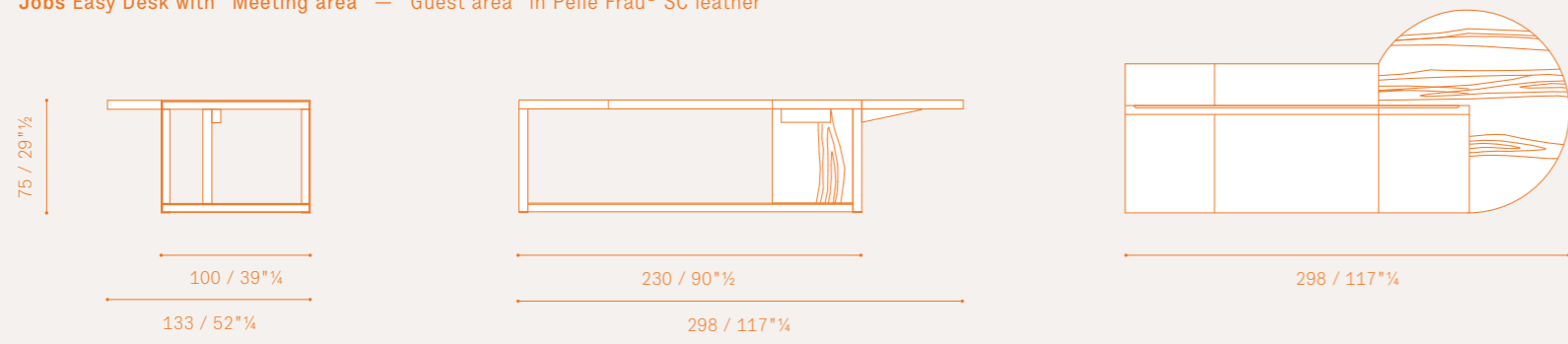

Jobs Easy Desk with "Meeting area" — "Guest area" in Oakwood

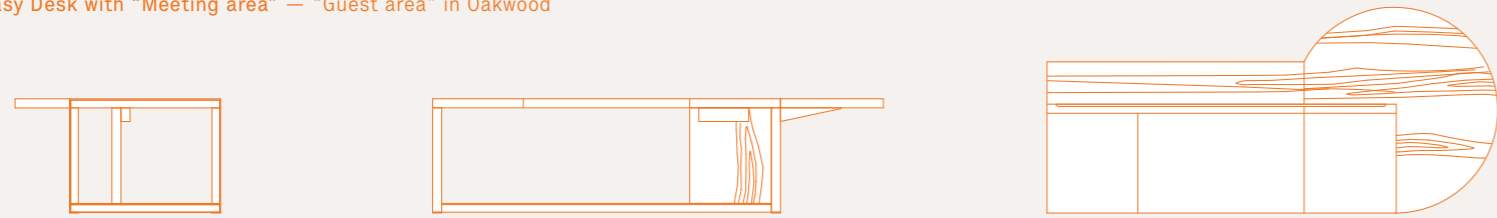

Jobs Easy Desk Large — "Guest area" in Pelle Frau® SC leather

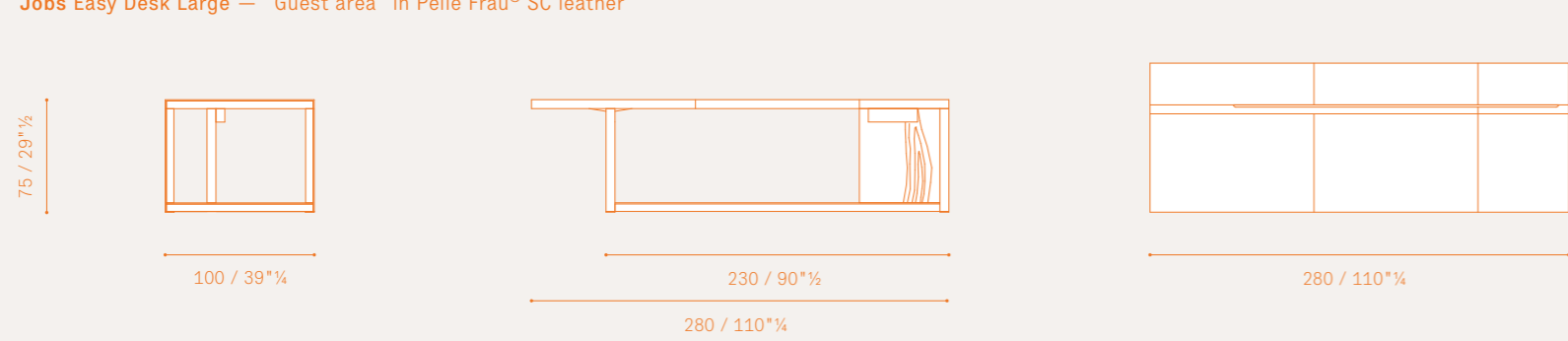

Jobs Easy Desk Large — "Guest area" in Oakwood

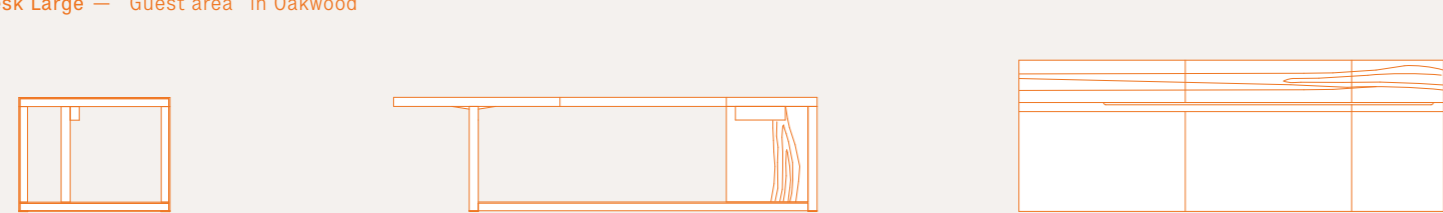

Jobs Meeting Table 266x150 cm — Pelle Frau® SC leather / Oakwood

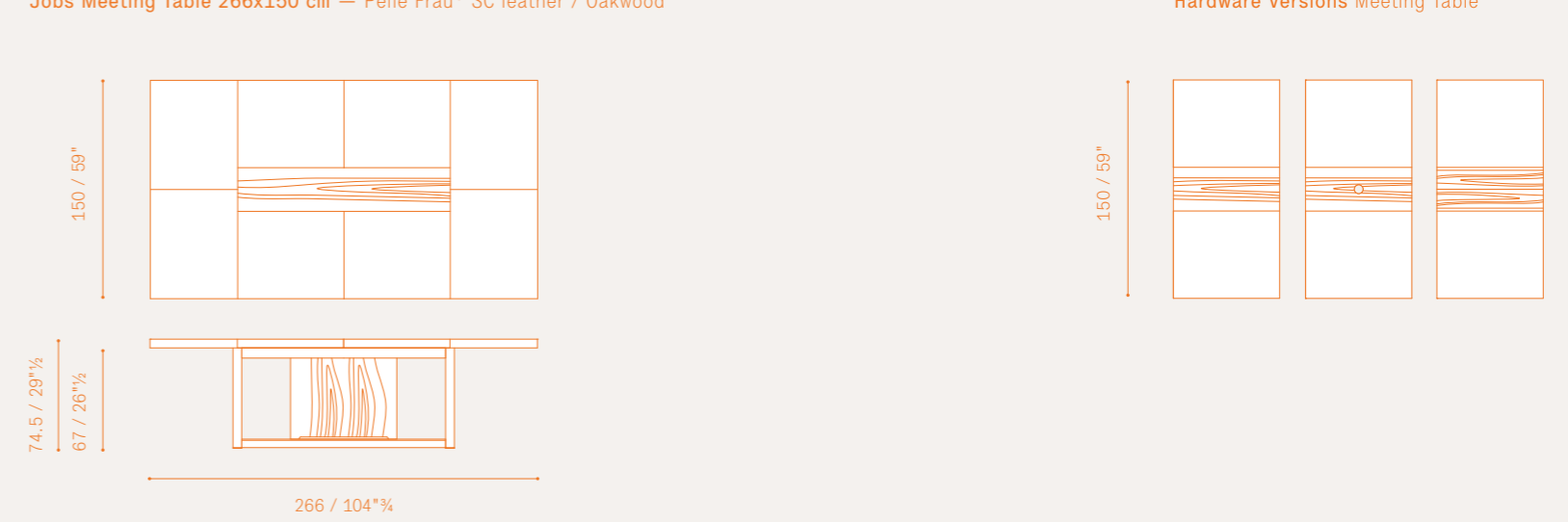

Jobs Meeting Table 339x150 cm — Pelle Frau® SC leather / Oakwood

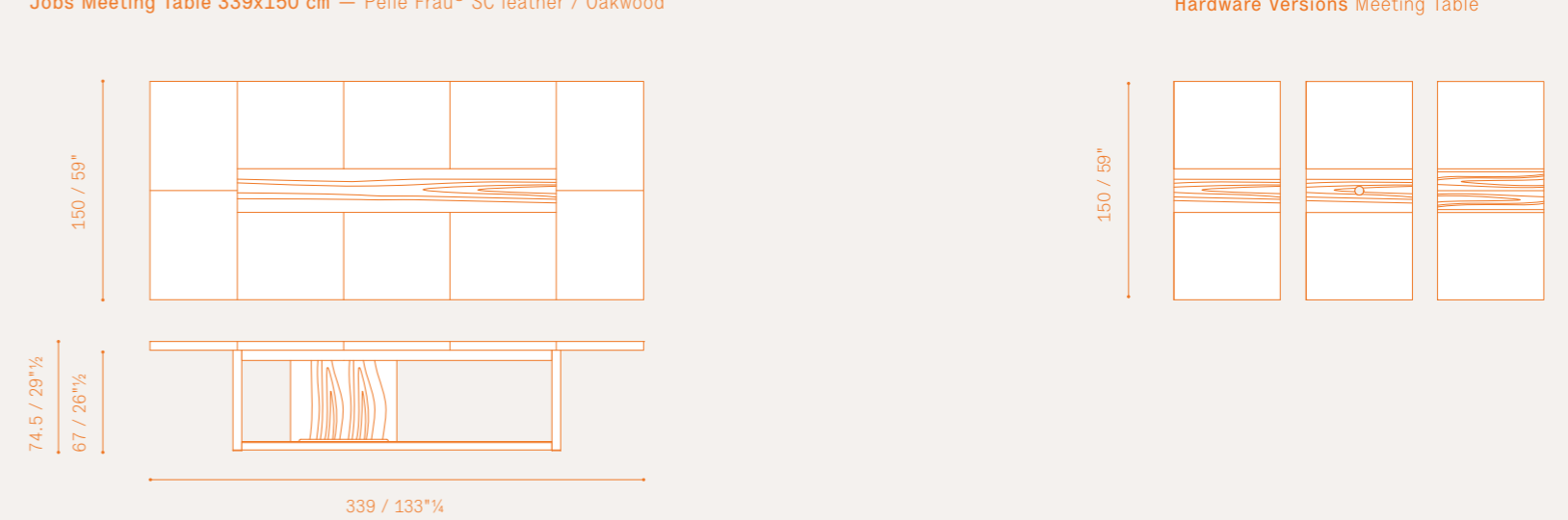

Jobs Meeting Table 412x150 cm — Pelle Frau® SC leather / Oakwood

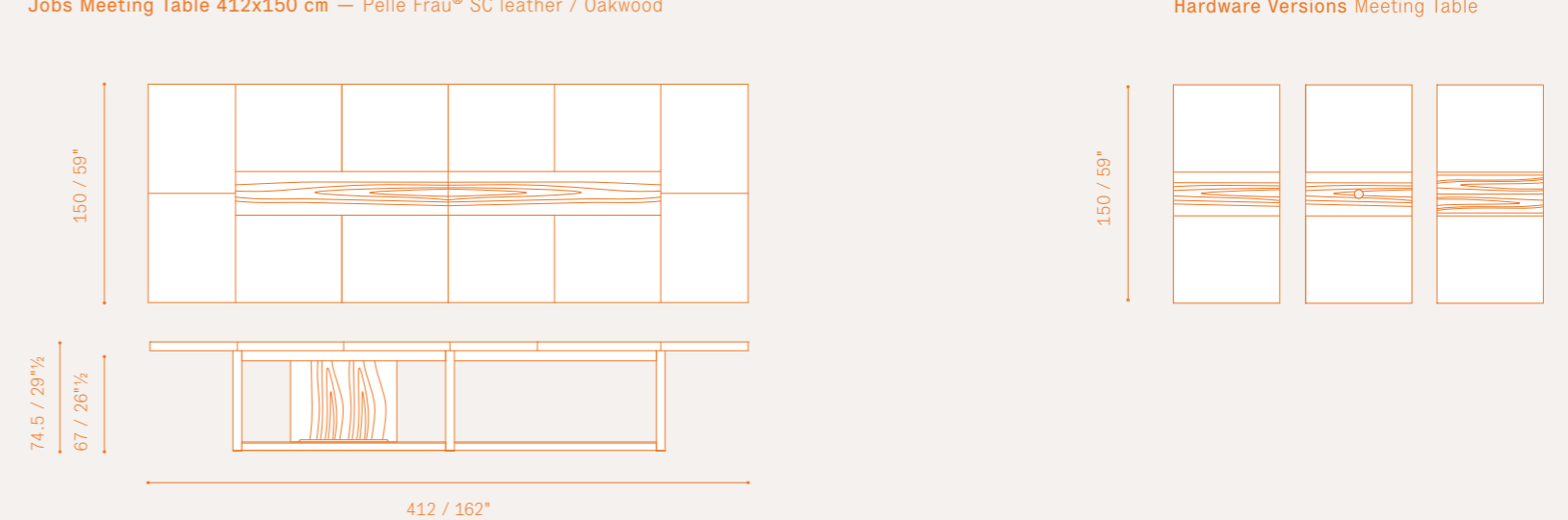

Jobs Meeting Table 485x150 cm — Pelle Frau® SC leather / Oakwood

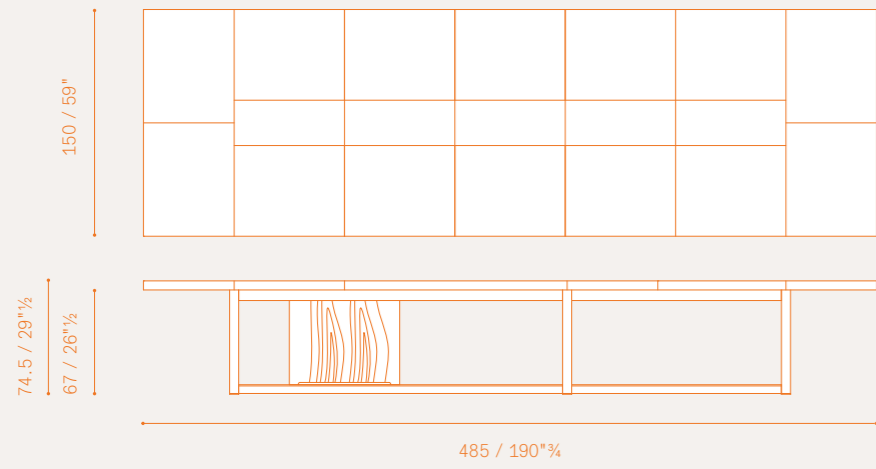

Hardware Versions Meeting Table

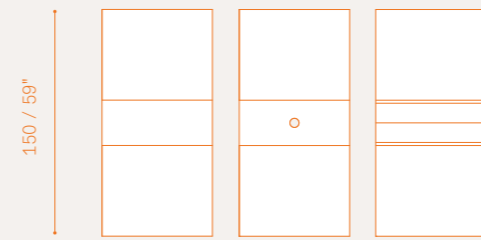

Jobs Meeting Table 704x150 cm — Pelle Frau® SC leather / Oakwood

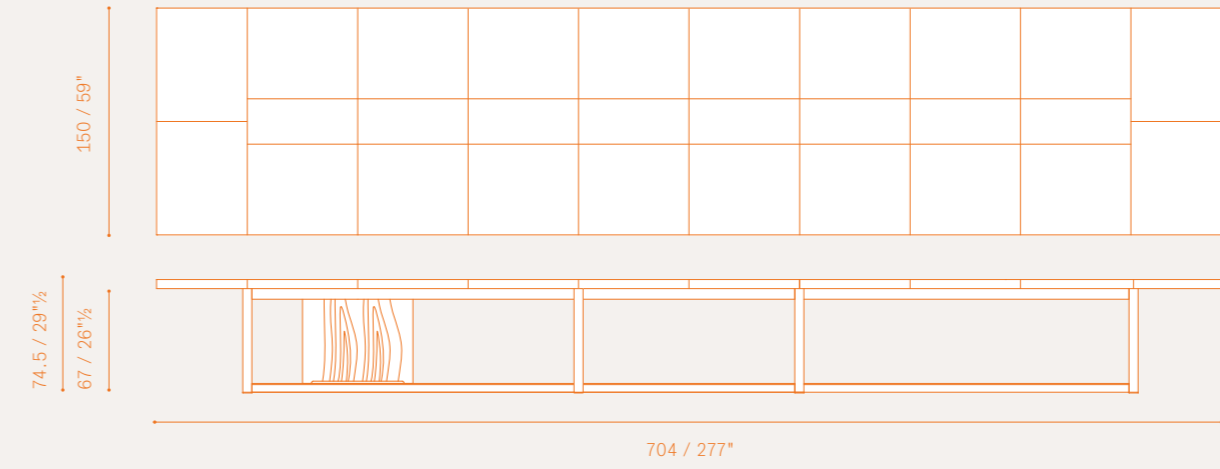

Optional: President Area

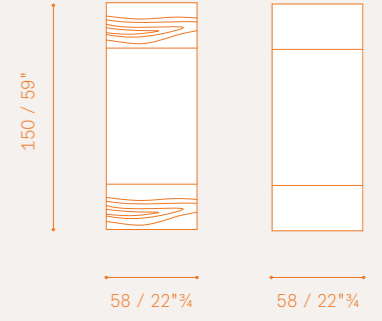

Jobs Meeting Table 558x150 cm — Pelle Frau® SC leather / Oakwood

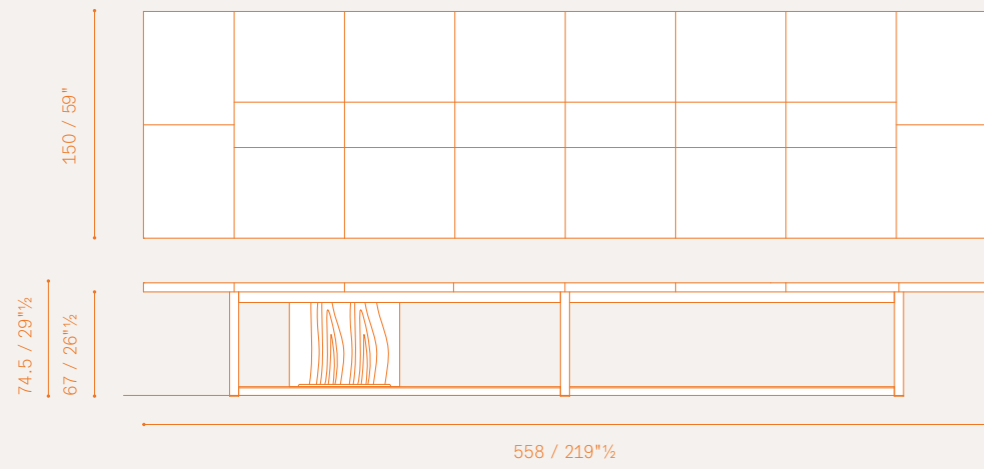

Hardware Versions Meeting Table

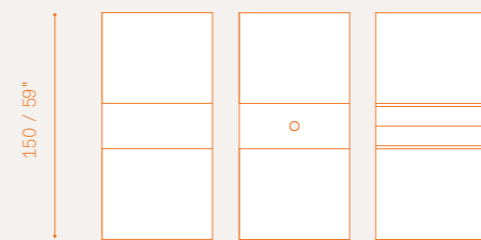

Jobs Meeting Table 631x150 cm — Pelle Frau® SC leather / Oakwood

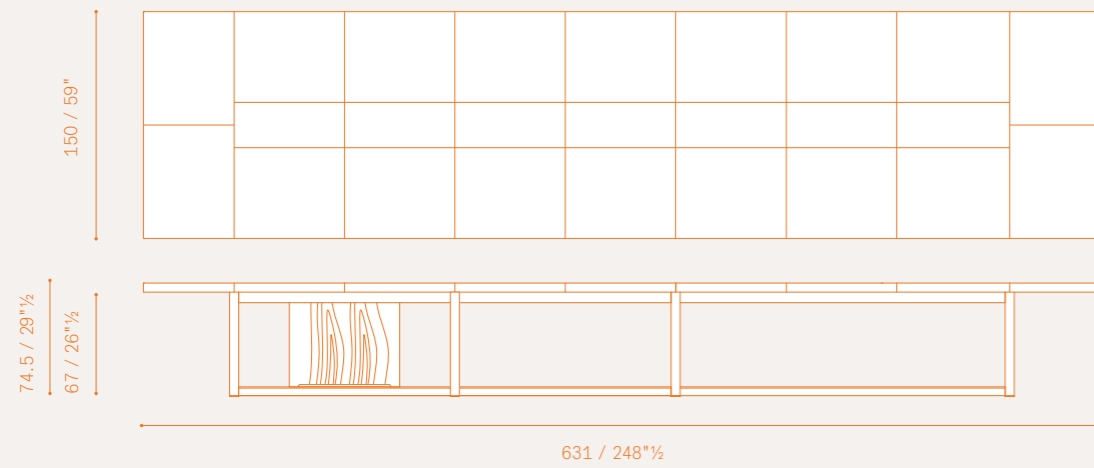

Hardware Versions Meeting Table

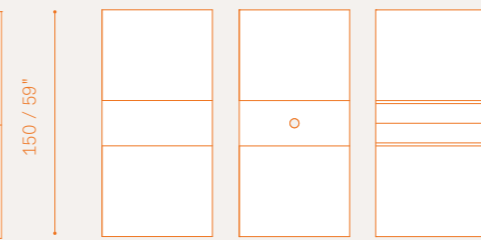

Jobs Bookcase Freestanding 177x145 cm — Pelle Frau® SC leather / Oakwood

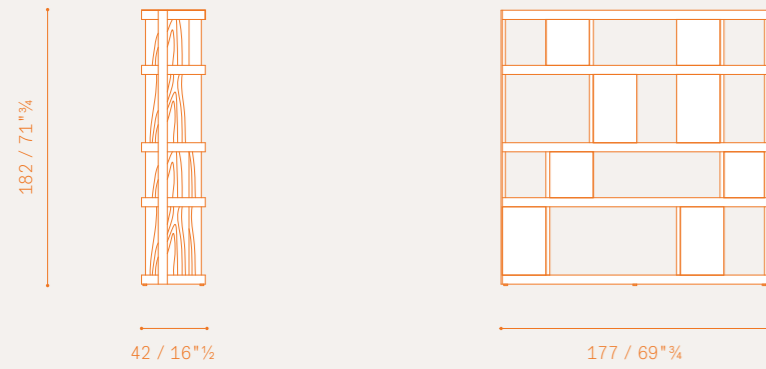

Jobs Bookcase Freestanding 234x145 cm — Pelle Frau® SC leather / Oakwood

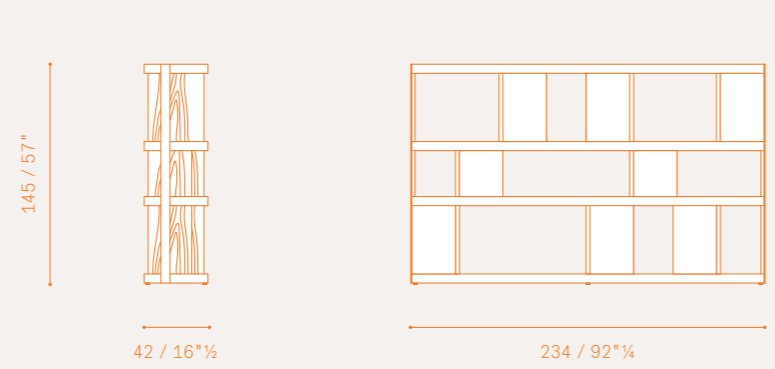

Jobs Bookcase Wall 177x145 cm — Pelle Frau® SC leather / Oakwood

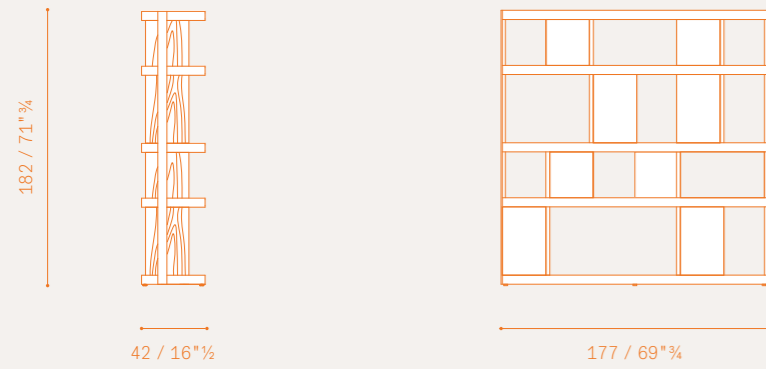

Jobs Bookcase Wall 234x145 cm — Pelle Frau® SC leather / Oakwood

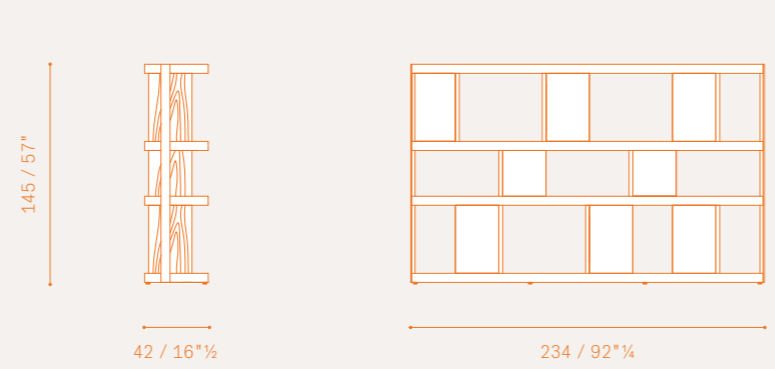

Jobs Low Cabinet 284 cm — 2 drawers and 2 filing cabinets and 1 compartment door / 3 compartments door

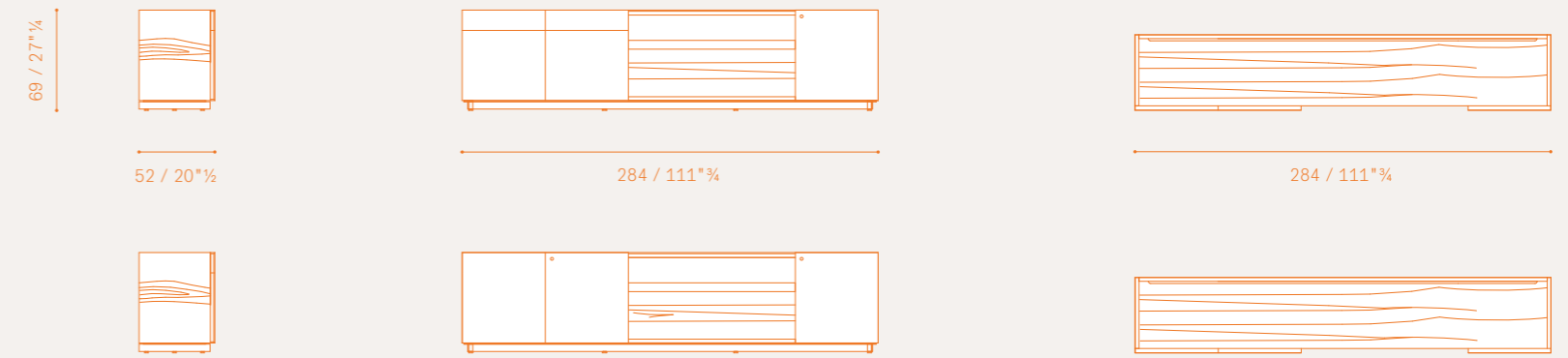

Jobs Low Cabinet 230 cm — 2 drawers and 2 filing cabinets / 2 compartments door

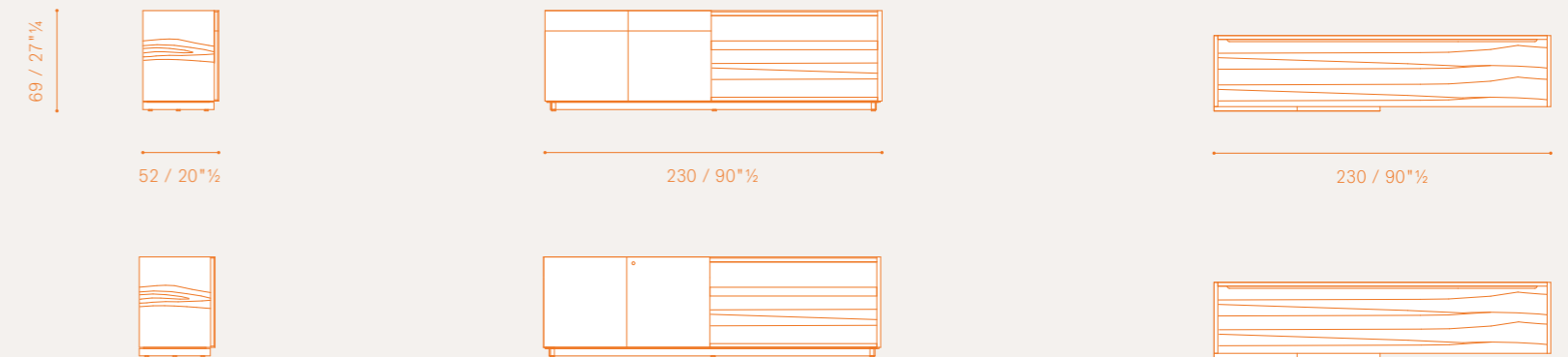

Jobs Drawer Unit

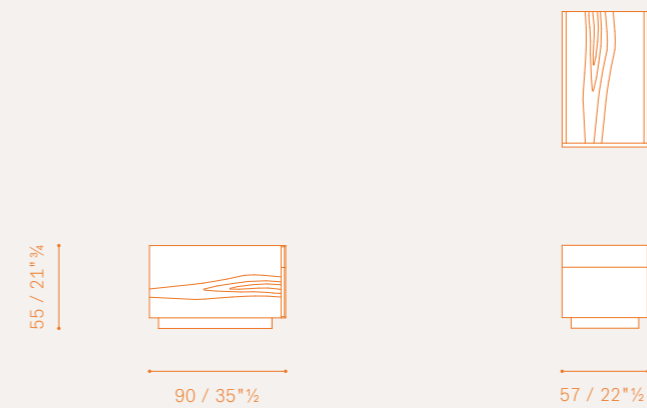

Lella and Massimo Vignelli

C.E.O. Cube



LELLA E MASSIMO VIGNELLI

Lella Vignelli è nata a Udine, si è laureata in architettura a Venezia. Massimo Vignelli è nato a Milano nel 1931, ha studiato architettura a Milano e a Venezia. Svolgono attività nel campo della grafica, programmi d'immagine coordinata per l'industria, segnaletica, disegno industriale; progettano mobili, interni e allestimenti. Originariamente a Milano e dal 1965 a New York, lo studio collabora con alcune fra le più importanti industrie e istituzioni americane e europee.

CONCEPT

La nuova linea esprime il desiderio di superfici leggere consono alle espressioni architettoniche contemporanee. Il contrasto tra il volume della cassettera-libreria e le superfici sottili del piano di scrittura ed il pannello di supporto, conferisce alla scrivania snellezza ed autorità, elementi caratteristici del management contemporaneo. Il tavolo riunioni riprende lo stesso linguaggio in dimensioni variabili, rettangolare, quadrato o tondo.

LELLA AND MASSIMO VIGNELLI

Lella Vignelli レッラ・ヴィニェッリはウディネで生まれ、ヴェネツィアで建築学の学位を取得。Massimo Vignelli マッシモ・ヴィニェッリ (1931-2014) はミラノで生まれ、ミラノとヴェネツィアで建築を学ぶ。Vignelliヴィニェッリ・アソシエイツ・スタジオをミラノで創設、1965年ニューヨークに移りアメリカやヨーロッパの有名企業や団体の仕事を手掛ける。二人はグラフィック、コーポレート・イメージ、ロゴやシンボル・マークのデザイン、インダストリアル・デザインの分野で活躍。オブジェ、家具調度品、インテリア、展示会場のデザイン設計も手掛けている。

LELLA AND MASSIMO VIGNELLI

Lella Vignelli was born in Udine and graduated in architecture in Venice. Massimo Vignelli was born in Milan in 1931 and studied architecture in Milan and Venice. Their work includes graphic design, corporate image work for industry, signs and industrial design; they design furniture, interiors and exhibition installations. Originally based in Milan and since 1965 in New York, the studio works with some of the most important American and European companies and institutions.

CONCEPT

スリムさで特徴を出す現代的な構成のデザイン。引き出しと本棚のキャビネットのボリュームとデスクの天板とそれを支えるパネルの薄さのコントラストが現代のエグゼクティブに求められるスマートさと威厳を感じさせる。会議用テーブルも同じコンセプトでデザインされ、長方形、正方形、円形、サイズも豊富。

CONCEPT

The new series epitomises the desire for light surfaces that are in keeping with contemporary architectural expression. The contrast between the volume of the drawer chest-bookcase and the slender surfaces of the desktop and the supporting panel gives the desk a streamlined and authoritative feel, distinctive characteristics of contemporary management. The meeting table adopts the same language in variable dimensions, rectangular, square or round.

LELLA AND MASSIMO VIGNELLI

Lella Vignelli 出生于意大利乌迪内，毕业于威尼斯建筑学院。Massimo Vignelli (1931-2014) 出生于米兰，并在米兰和威尼斯深造建筑学。一开始活跃于米兰，1965年起把工作重心转移到纽约，Vignelli 联合设计工作室与各个重量级的欧美公司都有着密切的合作关系。Lella 和 Massimo Vignelli 的工作范畴包括 图形设计、企业形象设计、标志及工业设计；同时他们也涉足配饰、家具、室内与展会装置设计。

理念

这一全新系列集中体现了对轻盈外观的渴望，表达建筑的当代性。抽屉柜与书柜的巨大体量与纤薄的桌面形成了鲜明反差，配合支撑侧板的设计，赋予这款办公桌流畅的外观与庄重的气场，塑造了一个当代管理者的性格特征。会议桌的理念也如出一辙，长方形、正方形或圆形的桌面款式有多种尺寸可供选择。





↑ C.E.O. Cube President Desk — Furniture Unit ↗ lower top and leg detail



Sistemi Direzionali — C.E.O. Cube

C.E.O. Office Furniture — C.E.O. Cube

エグゼクティブシステムズ — C.E.O. Cube

賢 椅様 漣 鏡 仟 仟 — C.E.O. Cube





↑ C.E.O. Cube Meeting Table Hardware with central doors — Top and leg detail ↗ President Area

Sistemi Direzionali — C.E.O. Cube

C.E.O. Office Furniture — C.E.O. Cube

エグゼクティブシステムズ — C.E.O. Cube

賢 椅様 濶 鑲 任 仔 — C.E.O. Cube

C.E.O. Cube Materials

La forma pura, la sintesi della materia, la solidità di una struttura tecnicamente avanzata. L'essenzialità geometrica unita all'esaltazione dei materiali, la Pelle Frau®, il legno, le leghe di alluminio.

PELLE FRAU® COLOR SYSTEM

Materia principale della serie C.E.O. Cube, la Pelle Frau® Color System esalta l'architettura dei tavoli riunione, delle scrivanie direzionali, dei contenitori e della libreria con vani a giorno. 96 possibili colori di pelle con cui rivestire il sottomano delle scrivanie o l'intero piano di lavoro, in abbinamento o in contrasto, il mobile cubo e il pannello di cortesia. Ma anche gambe e piano dei tavoli meeting, la cassettera, i cabinet e la bookcase sono interamente rivestiti in pelle.

NOCE CANALETTO

Finitura esclusiva delle desk, il noce Canaletto può essere scelto per le fasce laterali del piano di lavoro diversificandole dal sottomano in pelle. In questo caso anche le gambe sono in essenza come il piano.

ALLUMINIO LUCIDO

I dettagli che fanno la differenza. Il cubo che sostiene un lato della scrivania è dotato di due cassetti e un classificatore con maniglie in alluminio lucido completi di serratura. Sul lato esterno è dotato di un vano a giorno interamente rivestito in pelle e diviso da una griglia di ripiani in alluminio lucido. Anche il pannello di cortesia, rivestito in pelle, è in alluminio.

The pure form, the blend of materials, the solid, technically-advanced structure, the soul of Poltrona Frau. A combination of clear-cut geometric design and fine materials, from noble Pelle Frau® leather to wood and aluminium alloys.

PELLE FRAU® LEATHER FROM THE COLOR SYSTEM

The main material of the C.E.O. Cube series, the Pelle Frau® leather from the Color System exalts the architecture of the meeting tables, the executive desks, the storage units and the bookcase with open compartments. 96 possible colours of leather with which to upholster the desk pad or the entire desktop, matching or contrasting, the cube and the modesty panel. The legs and the surface of the meeting tables, the drawer chest, the cabinets and the bookcase are also completely upholstered in leather.

CANALETTO WALNUT VENEER

An exclusive finish for the desks, the Canaletto walnut veneer can be chosen for the edges of the work surface to differentiate them from the leather desk pad. In this case the legs are also in wood, like the desk surface.

POLISHED ALUMINIUM

It is the details that make the difference. The cube that supports one side of the desk is fitted with two drawers and a filing cabinet with handles in polished aluminium, complete with lock. Externally, there is an open compartment entirely upholstered in leather divided up by a grid of polished aluminium shelves. The leather-upholstered modesty panel is also in aluminium.

すっきりとしたフォルム、先進的技術を駆使した構築の中で異素材の組合せを活かす。エッセンシャルなデザインが Pelle Frau® ペッレ・フラウ、ウッド、アルミ合金という素材の美しさを際立たせる。

PELLE FRAU® COLOR SYSTEM ペッレ・フラウ® カラー・システム

C.E.O. Cube の主な素材である Pelle Frau® Color System ペッレ・フラウ® カラー・システムが会議用テーブル、エグゼクティブ・デスク、キャビネット類、本棚のデザインの美しさを際立たせる。立方体および使用者の脚を隠す目隠しパネルの革張りと同色又はコントラスト・カラーを 96 色の中から選び、デスクパッドやテーブルトップ全体を革張りする事が可能。会議用テーブルの脚、天板、引き出し、キャビネット、ブックケースも総革張り。

NOCE CANALETTO カナレット・ウォールナット

デスクの高級仕上げ。革張りのデスクパッドを中心に、天板の両サイドの帯状部分に Canaletto カナレット・ウォールナットを組み合わせる事もできる。この場合、脚もウッドとなる。

光沢仕上げのアルミニウム

違いはディティールから生まれる。デスクの片側を支える立方体には光沢仕上げアルミ製の取っ手が付いた引き出しが2つとファイリング・キャビネットが付いており、錠前付き。外側に向いた面は覆いが無く、総革張りで、光沢仕上げアルミ製の格子状棚板で仕切られている。使用者の脚を隠すための目隠しパネルもアルミ製の革張り。

纯粹的外形，丰富的材质，扎实高科技的框架结构，汲取 Poltrona Frau 的精髓。这款桌子是简洁剪裁的几何外形设计与精细材质的完美结合，从引以为豪的 Pelle Frau® 皮革到木材，再到铝合金。

PELLE FRAU® 色彩系统中的皮革

C.E.O. Cube 系列中最主要的材质便是从 Pelle Frau® 色彩系统中精选出的皮革，进一步提升了会议桌、办公桌、储物单元以及开放式的书柜单元的建筑感。96 种皮革色彩可供挑选，用来包裹桌面的写字区域，甚至是整张桌面，即可以同色，也可以玩转对比撞色，为立方体的储物柜或朴实的侧板选择不同色彩。会议桌、抽屉柜、储物柜以及书柜的支撑脚和表面均包裹皮革。

CANALETTO WALNUT VENEER CANALETTO 胡桃木贴皮

作为这款办公桌的独特饰面，Canaletto 胡桃木贴皮可以适用于办公区域表面的边缘，用来与写字区域做区隔。在这个款式中，桌脚会采用与桌面一样的木饰面。

POLISHED ALUMINIUM 抛光铝合金

细节制胜，与众不同。支撑办公桌一侧的立方体单元配备有2个抽屉与1个文件抽，均使用抛光铝质把手，并安装了锁扣系统。不仅如此，我们还额外设计了一个开放式的储物单元，全部包裹皮革，内置网格状的铝合金搁板隔断。在皮革包裹下的侧板也为铝合金材质。



C.E.O. Cube Desk

Le scrivanie Desk hanno struttura asimmetrica con telaio portante in tubolare e traverse di lamiera di metallo. Nelle foto, il rivestimento della Desk è tutto in Pelle Frau® SC 99 Carrubo.

The Desks are asymmetric in design with supporting structure in tubular metal and crossbars in sheet metal. In the photos, the Desk is entirely upholstered in SC 56 Siena Pelle Frau® leather.

Desk デスクはアシンメトリー、パイプ材の支柱とメタル製の板の梁で支えている。写真の Desk の革張りは Pelle Frau® SC 56 Siena ベッレ・フラウ® SC 56 シエナ。

这款办公桌拥有不对称的设计，支撑结构为管状金属以及由金属片组成的横档组成而成。图示款中，办公桌整体包裹 SC 56 Sieno Pelle Frau® 皮革。

Il piano e la gamba sono realizzati con doppia pannellatura a bordo smussato, rivestiti sul lato esterno in Pelle Frau® del Color System oppure impiallacciati in noce Canaletto. Il sottomano è sempre in pelle.

The desktop and leg are produced with double-panelling with rounded edges, upholstered on the outside with Pelle Frau® leather from the Color System or finished in Canaletto walnut veneer. The desk pad is in leather.

天板と脚はパネルを二重にしており、縁に丸みをつけている。外側は Pelle Frau® del Color System カラー・システムのベッレ・フラウ® で革張り又は Canaletto カナレット・ウォールナット。デスクパッドは常に革張り。

桌面与桌腿采用圆滑棱角的双面镶板制造而成，外侧包裹从 Pelle Frau® 的色彩系统中精选出的皮革，或选用 Canaletto 胡桃木贴皮。写字区域为皮革软包。



C.E.O. Cube Desk

Nella foto il rivestimento della desk è in Pelle Frau® SC 23 Tortora per sottomano e cubo. I pannelli laterali del piano di lavoro e la gamba sono impiallacciati in noce Canaletto. Qui nella versione con pannello di cortesia.

In the photo, the desk pad and cube are upholstered in SC 23 Tortora Pelle Frau® leather. The lateral panels of the desktop and the leg have a Canaletto walnut veneer. This version comes with modesty panel.

写真の Desk のデスクパッドと立方体の革張りは Pelle Frau® SC 23 Tortora ベッレ・フラウ® SC 23 トルトラ。テーブルトップのサイド・パネルと脚は Canaletto カナレット・ウォールナット。写真の製品は使用者の脚を隠すための目隠しパネル付。

图示款中，桌面的写字区域与储物立方体包裹 SC 23 Tortora Pelle Frau® 皮革。桌子的侧板与桌腿为 Canaletto 胡桃木贴皮。此款办公桌为带背板式。

Il cubo che sostiene un lato della scrivania è dotato di un sistema che consente la rotazione su se stesso e può essere montato a destra o a sinistra della scrivania.

The cube that supports one side of the desk is fitted with a system allowing it to rotate about itself, and can be mounted to the left or right of the desk.

デスクの片側を支える立方体は軸を中心として回転するので、デスクの右側にも左側にも取り付けの事が可能。

以储物立方体为桌面一边支撑的款式中，安装了中轴系统，可以让立方体围绕自身轴心旋转，也可以根据需要安装在桌子的左侧或右侧。



C.E.O. Cube Easy Desk

Nella foto, scrivania Easy Desk in noce Canaletto con sottomano rivestito in Pelle Frau® SC 23 Tortora

In the photo, Easy Desk with Canaletto walnut veneer and desk pad in Pelle Frau® SC 23 Tortora leather.

写真の製品は Canaletto カナレット・ウォールナットの Easy Desk、デスクパッドの革張りは Pelle Frau® SC 23 Tortora ベッレ・フラウ® SC 23 トルトラ。

图示款中，这款电脑桌为Canaletto胡桃木贴皮，写字区域覆盖 Pelle Frau® SC 23 Tortora 皮革。



L'Easy Desk ha una struttura a "C" rovesciata e può essere attrezzata con una cassettera con ruote.

The Easy Desk has an upturned "C" structure and can be equipped with an additional wheeled drawer unit.

Easy Desk は "C" を逆にした形、キャスター付の引き出しキャビネットを加える事も可能。

这款电脑桌外形设计为一个上下翻转的倒 "C" 型结构，还可以额外配备一个带脚轮的抽屉柜。



C.E.O. Cube Easy Desk

Nella foto sopra la scrivania Easy Desk è rivestita in Pelle Frau® bicolore: piano di lavoro e gambe in SC 64 Cannella e sottomano in Pelle Frau® SC 69 Iroko.

In the above photo the Easy Desk is upholstered in two-tone Pelle Frau® leather: desktop and legs in SC 64 Cannella leather and desk pad in SC 69 Iroko leather.

写真の Easy Desk の革張りは Pelle Frau® bicolore ベッレ・フラウ® のバイカラー。天板と脚の色は SC 64 Cannella カンネッラ、デスクパッドの色は Pelle Frau® SC 69 Iroko ベッレ・フラウ® SC 69 イロコ。

上图所示的电脑桌款式包裹双色拼接的 Pelle Frau® 皮革：分别是桌面与桌腿的部分为 SC 64 Cannella 皮革，写字区域为 SC 69 Iroko 皮革。



Nella foto sotto la scrivania Easy Desk è totalmente rivestita in Pelle Frau® SC 64 Cannella.

In the photo below the Easy Desk is entirely upholstered in SC 64 Cannella Pelle Frau® leather.

下の写真の Easy Desk は Pelle Frau® SC 64 Cannella ベッレ・フラウ® SC 64 カンネッラで全体を革張り。

下图所示的电脑桌款式整体包裹 SC 64 Cannella Pelle Frau® 皮革。





Vista zenitale del piano di lavoro della scrivania con dettaglio del vano adibito al passaggio cavi e della fuoriuscita sul piano attraverso auna borchia metallica.

Overhead view of the desktop with detail of the compartment designed to accommodate cables and their emergence on the tabletop through the use of a metal grommet.

デスクの天板を上から見ると配線のためのコードが通るスペースと天板に抜ける部分のメタル・パーツが見て取れる。

桌面顶视图，俯视电线收纳部件设计，通过使用金属环扣可以使线缆通到桌面上。

C.E.O. Cube Desk — Dettaglio tecnico del passaggio cavi — Technical details of the cable passage — ケーブル配線に関する技術的詳細 — 电缆管道的技术细节

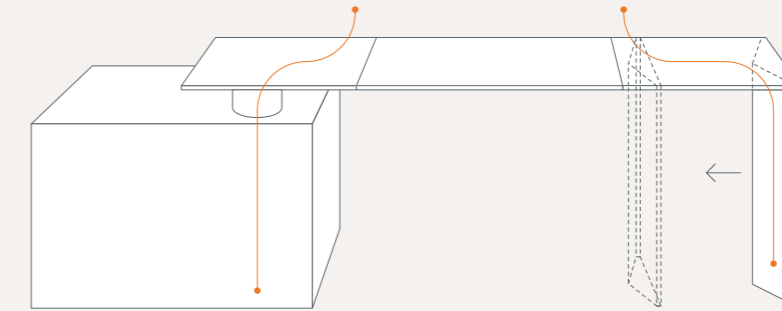

C.E.O. Cube Easy Desk — Dettaglio tecnico del passaggio cavi — Technical details of the cable passage — ケーブル配線に関する技術的詳細 — 电缆管道的技术细节

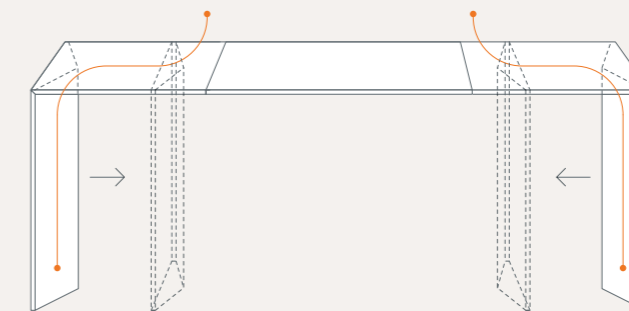

C.E.O. Cube Round Meeting Table ø180cm / ø150cm

Tutti i tavoli Meeting hanno grandi gambe cilindriche in tubolare metallico, leggermente imbottite e rivestite in pelle. La versione rotonda è disponibile in due dimensioni, ø 180 cm e ø 150 cm, declinate in due diverse altezze, h. 75 cm e h. 50 cm.

Nelle foto il rivestimento è in Pelle Frau® SC 28 Seppia per la versione grande e SC 128 Carminio per la versione più piccola.

All of the Meeting tables have large cylindrical tubular metal legs, lightly padded and upholstered in leather. The round version is available in two sizes, ø 180 cm and ø 150 cm, which come in two different heights, h. 75 cm and h. 50 cm. In the photos the large version is upholstered in SC 28 Seppia Pelle Frau® leather and the smaller version in SC 128 Carminio leather.

すべての Meeting テーブルには中空のメタル製円筒に薄くパッドを巻いて革張りした脚が付いている。円形のモデルには2つのサイズ、ø 180 cm と ø 150 cm、それぞれ高さは 75 cm と 50 cm。写真の製品の大きいサイズの革張りは Pelle Frau® SC 28 Seppia ベッレ・フラウ® SC 28 セビア、小さいサイズは SC 128 Carminio カルミニオ。

所有的会议桌都拥有圆柱形金属桌腿，部分以皮革软包加以装饰点缀。圆形的款式有两种尺寸可供选择，分别是 ø 180 cm 和 ø 150 cm，它们各自对应不同的高度，h. 75 cm and h. 50 cm。图示款中的大尺寸办公桌软包 SC 28 Seppia Pelle Frau® 皮革；而小尺寸办公桌则覆盖 SC 128 Carminio 皮革。

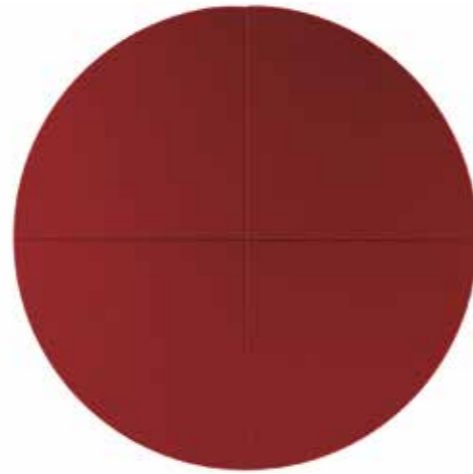

C.E.O. Cube Square Meeting Table

La versione quadrata ha dimensioni 150 cm x 150 cm. Nella foto il rivestimento è in Pelle Frau® SC 53 Creta.

The square version is 150 cm x 150 cm. In the photo, SC 53 Creta Pelle Frau® leather is used for the upholstery.

正方形のモデルのサイズは 150 cm x 150 cm。写真の製品の革張りは Pelle Frau® SC 53 Creta ベッレ・フラウ® SC 53 クレタ。

方形款的尺寸为 150 cm x 150 cm。图示款中，软包套面为 SC 53 Creta Pelle Frau® 皮革。



C.E.O. Cube Modular Meeting Table

Il piano dei tavoli Meeting è leggermente imbottito e supportato da un pannello inferiore in fibra di legno verniciato nero texturizzato e predisposto per il passaggio cavi. Nel vano interposto e sulle cavità delle gambe sono predisposti specifici alloggiamenti per i cablaggi. Nelle foto il tavolo è in Pelle Frau® SC 28 Seppia.

The surface of the Meeting tables is lightly padded and supported by a wood fibre panel below in a textured black finish designed to accommodate cables. The compartment and hollow legs have been specifically designed to accommodate cables. In the photos, the table is upholstered in SC 28 Seppia Pelle Frau® leather.

会議用テーブルの天板は薄いパッド入りで、ウッド・ファイバー板にブラック塗装とテクスチャーを施したパネルで下から支え、配線を通すこともできるようになっている。配線を通すスペースや脚の窪みには配線用の溝が切り込んである。写真のテーブルの革張りは Pelle Frau® SC 28 Seppia ベッレ・フラウ® SC 28 セビア。

这款会议桌的表面以皮革软包稍加修饰，底下由木纤维板支撑，表面为黑色纺织纹理饰面，预先设计有电线收纳功能。隔断与中空桌腿都是特别设计用来收纳或通过线缆。图示款为整体包裹 SC 28 Seppia Pelle Frau® 皮革。

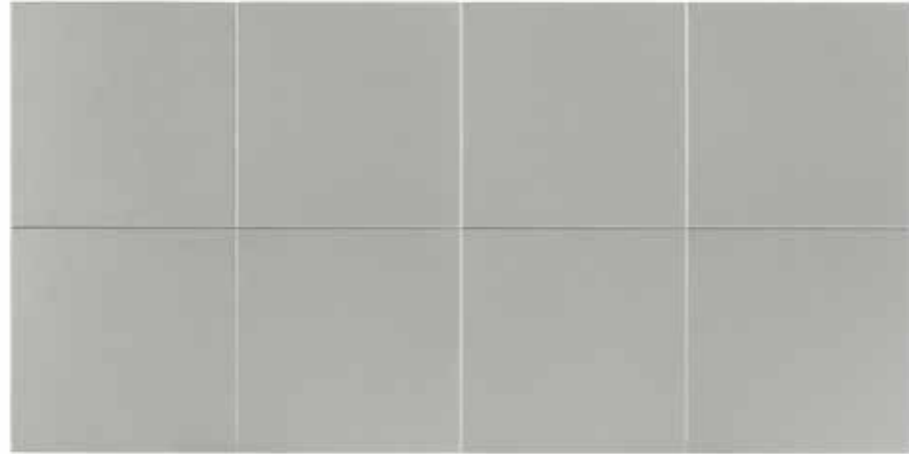

I tavoli da riunione modulari, nelle versioni rettangolare e ovale, sono disponibili in sette diverse dimensioni che spaziano da 296 cm a 734 cm. Nelle foto il rivestimento è in Pelle Frau® SC 3 Grigio.

The modular meeting tables, in the rectangular and oval versions, are available in seven different sizes ranging from 296 cm to 734 cm. In the photos they are upholstered in SC 3 Grigio Pelle Frau® leather.

モジュラー式会議用テーブルには長方形とオーバルがあり、296 cm から 734 cm まで 7 つのサイズが用意されている。写真の製品の革張りは Pelle Frau® SC 3 Grigio ベッレ・フラウ® SC 3 グレー。

模块化的会议桌，长方形及椭圆形的款式分别有从 296 cm 到 734 cm 的 7 种不同尺寸可供挑选。图示款为包裹 SC 3 Grigio Pelle Frau® 皮革。

Tavolo rettangolare con President Area rivestita in Pelle Frau® SC 28 Seppia

Rectangular meeting table with President Area upholstered in SC 28 Seppia Pelle Frau® leather.

Pelle Frau® SC 28 Seppia ベッレ・フラウ® SC 28 セビアでプレジデント・エリアを革張りした長方形のモデル。

长方形款，行政区域包裹 SC 28 Seppia Pelle Frau® 皮革。

C.E.O. Cube Modular Meeting Table Oval / Rectangular



C.E.O. Cube Modular Meeting Table Hardware

Con pannelli centrali

With central panels

センター・パネルから

中央面板



Con pannelli centrali e borchie passacavi

With central panels and cable tidy grommets

センター・パネルと配線用メタル・パーツを通して

带电线收纳管的中央面板



Con sportelli centrali

With central doors

センターの開口部から

可开合中央面板



Sono disponibili 4 versioni: la versione standard con piano semplice e 3 versioni Hardware diversamente attrezzabili per il passaggio dei cavi elettrici.

They are available in 4 versions: the standard version with straightforward surface and 3 Hardware versions that can be furnished in different ways to accommodate electrical cables.

4つのバージョンが用意されている: スタンダード・バージョンはシンプルな天板。ハードウェア・バージョンが3種類あり、それぞれ配線の通し方が異なる。

有4种款型可供挑选: 标准款为平直的桌面设计, 另有3款可按照不同摆放需要安装相应五金件, 用来收纳电线, 它们分别是。



C.E.O. Cube Meeting Table — Dettaglio tecnico del passaggio cavi — Technical details of the cable passage — ケーブル配線に関する技術の詳細 — 电缆管道的技术细节

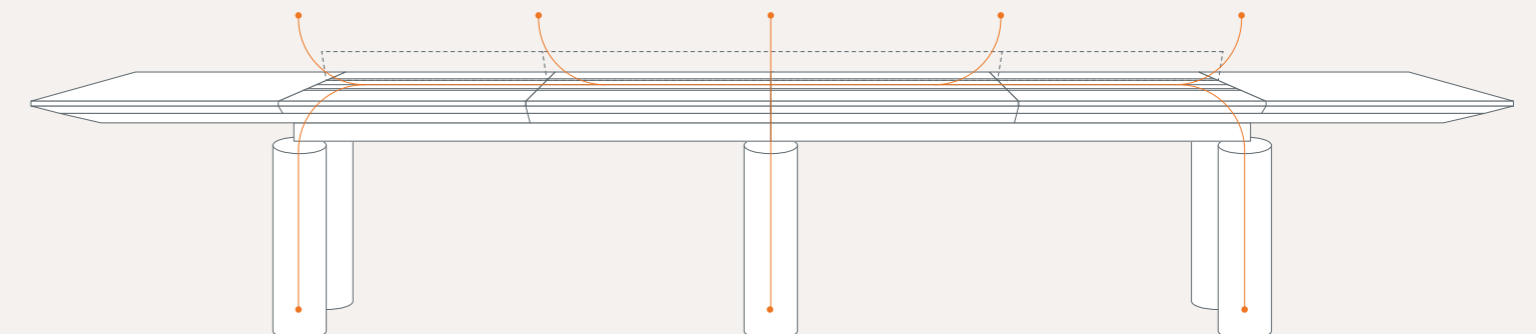
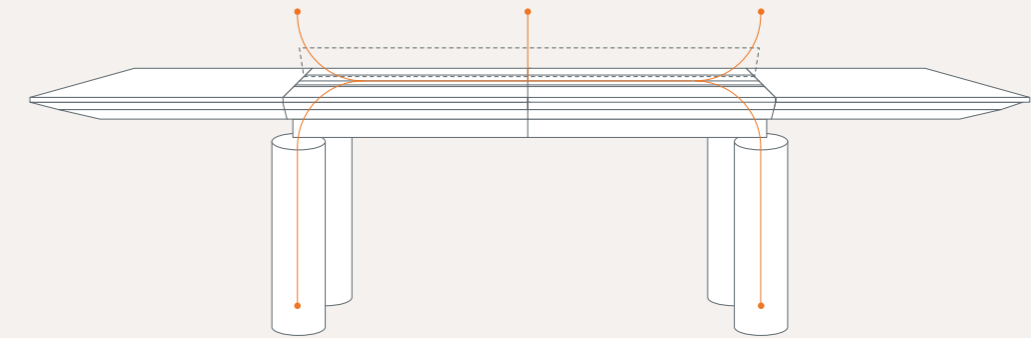

C.E.O. Cube Modular Meeting Table Hardware

Vista in sezione del piano di lavoro di un tavolo riunione versione Hardware con sportelli con evidenza del vano sotto piano predisposto per accogliere i cavi.

Cross-section of the work surface of a Hardware version meeting table with doors, highlighting the compartment located under the tabletop designed to accommodate cables.

ハードウェアバージョンの会議用テーブルの開口部がある天板の断面。天板の下に配線を通すスペース。

此图为带开合面板的会议桌款式中，工作台面的横截面，突出了安装在台面下用来收纳线缆的隔断细节。



C.E.O. Cube Low Cabinet / Small Cabinet

210 cm o 120 cm. Entrambi i cabinet sono dotati di ante apribili con leggera pressione e hanno l'interno dei vani ed il retro laccati nero opaco. Top, fianchi ed ante rivestiti in Pelle Frau® Color System. Il rivestimento dei cabinet nelle foto è in Pelle Frau® SC 98 Ribes

210 cm or 120 cm. Both cabinets have touch-latch doors and the interiors and the backs are painted in matt black. Top, sides and doors are upholstered in Pelle Frau® leather from the Color System. The cabinets in the photos are upholstered in SC 98 Ribes Pelle Frau® leather.

210 cm もしくは 120 cm。どちらのキャビネットも軽く押しただけで開く扉。内部と裏側はマットなブラック塗装。外側はトップもサイドも扉も Pelle Frau® Color System カラー・システムのベッレ・フラウ® で革張り。写真のキャビネットの革張りは Pelle Frau® SC 98 Ribes ベッレ・フラウ® SC 98 リーベス。

210 cm or 120 cm two sizes of cabinet. Any one of the styles is equipped with touch-latch doors, interior surfaces and back panels are painted with matt black. Top, sides and doors are upholstered with Pelle Frau® leather selected from the Color System. The cabinet in the photo is upholstered with SC 98 Ribes Pelle Frau® leather.



C.E.O. Cube Bookcase

Zoccolo in acciaio verniciato nero con piedini regolabili. Top, interno dei vani a vista e retro laccati nero opaco. Fianchi e apertura centrale rivestiti in Pelle Frau® del Color System. Nella foto il rivestimento è in Pelle Frau® SC 21 Amianto.

Black painted steel base equipped with adjustable feet. Top, interiors and backs of the open compartments are painted matt black. Sides and central opening upholstered in Pelle Frau® leather from the Color System. In the photo the upholstery is in Pelle Frau® SC 21 Amianto.

ブラック塗装仕上げスチール製の台は調節可能な足付。トップ、内側に見える部分と裏側はマットなブラック塗装。サイドと中央部の革張りは Pelle Frau® del Color System カラー・システムのベッレ・フラウ®。写真の製品の革張りは Pelle Frau® 21 Amianto ベッレ・フラウ® 21アミアント。

黑色漆面钢结构底座，配备可调节垫脚。顶面，以及开放式单元的内部表面与背板均内部表面以及背板涂刷黑色哑光漆。侧板与中央的镂空部分包裹 Pelle Frau® 色彩系统中精选出的皮革。

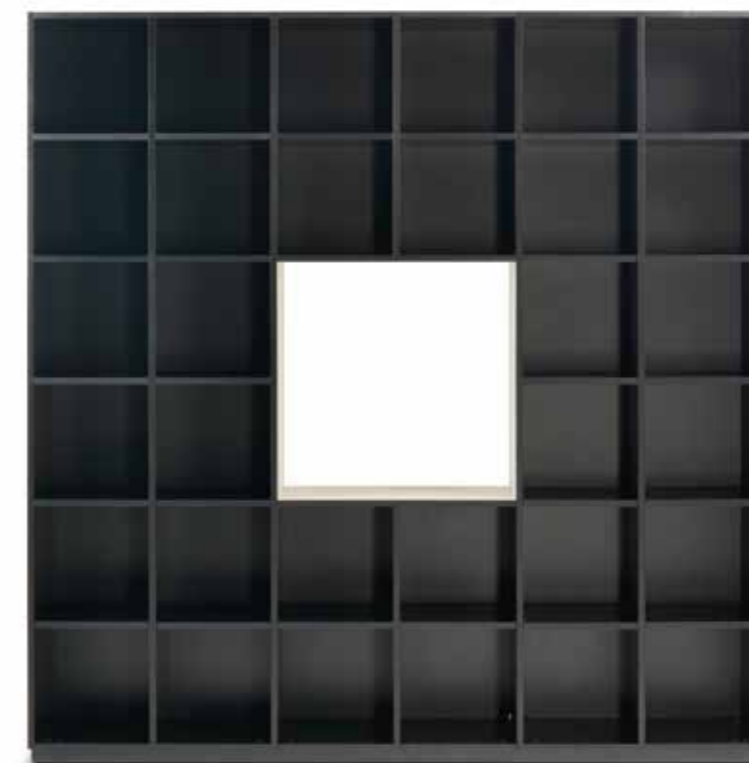

C.E.O. Cube Desk — Pelle Frau® SC leather

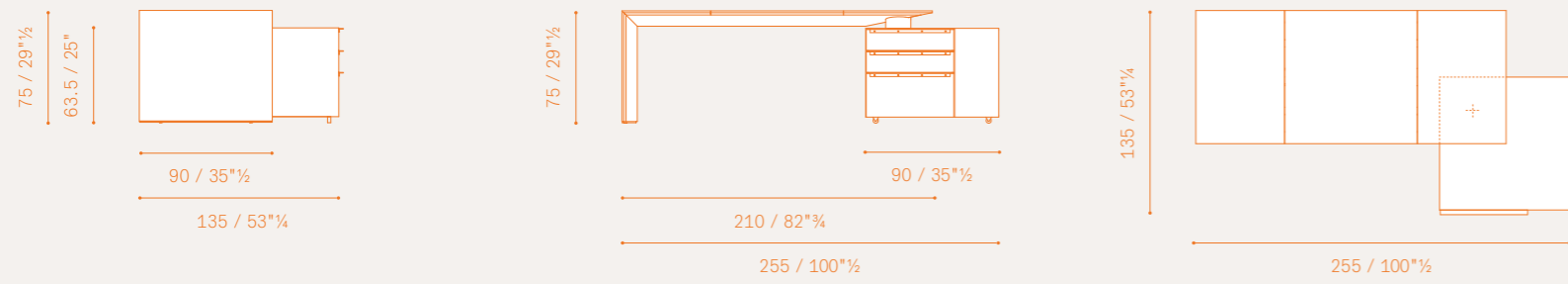

C.E.O. Cube Desk — Canaletto walnut / Pelle Frau® SC leather

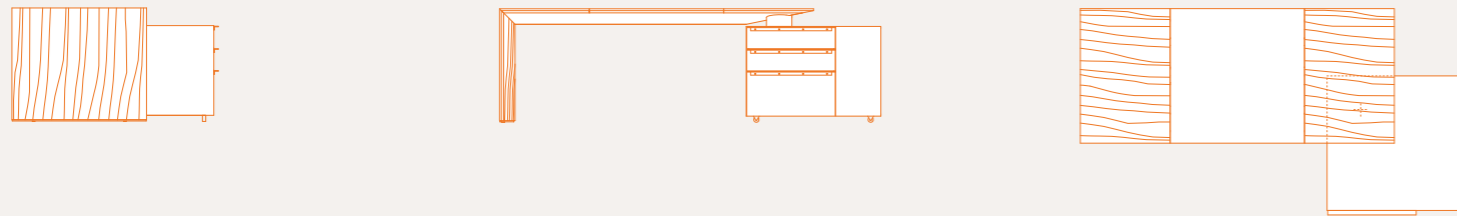

C.E.O. Cube Desk with modesty panel — Pelle Frau® SC leather

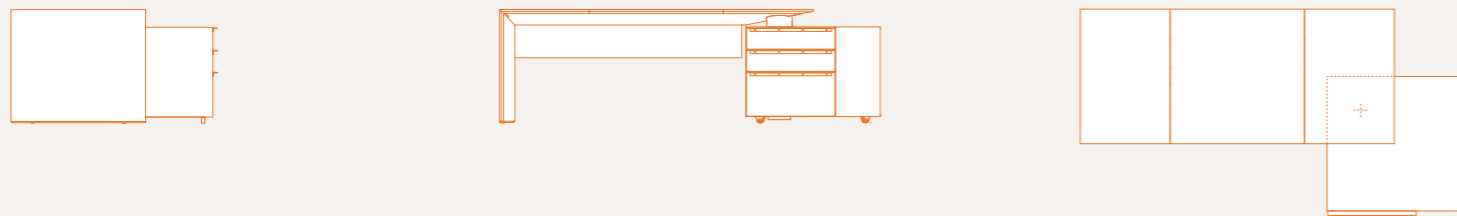

C.E.O. Cube Desk with modesty panel — Canaletto walnut / Pelle Frau® SC leather

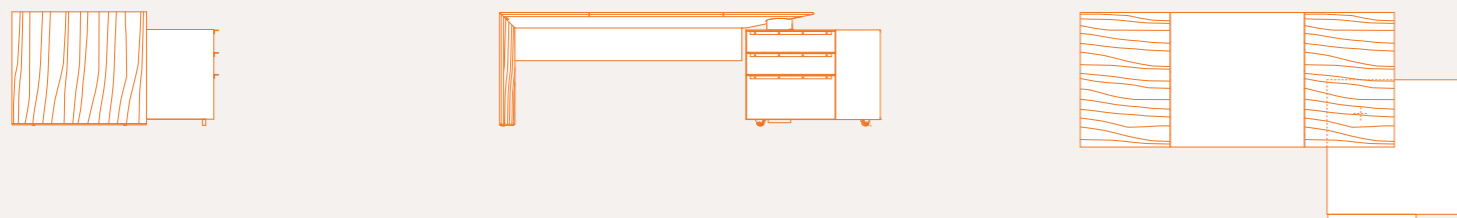

C.E.O. Cube Easy Desk — Pelle Frau® SC leather

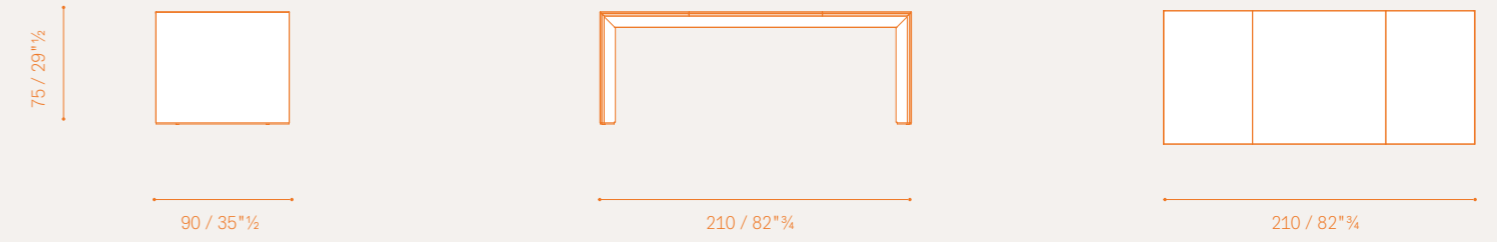

C.E.O. Cube Easy Desk — Canaletto walnut / Pelle Frau® SC leather

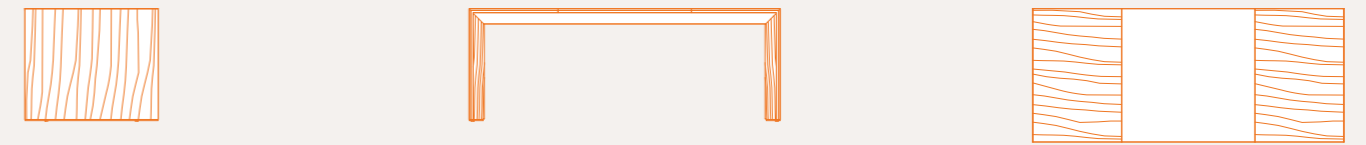

C.E.O. Cube Easy Desk with modesty panel — Pelle Frau® SC leather



C.E.O. Cube Easy Desk with modesty panel — Canaletto walnut / Pelle Frau® SC leather



C.E.O. Cube Meeting Table Round meeting table ø 180 — Pelle Frau® SC leather

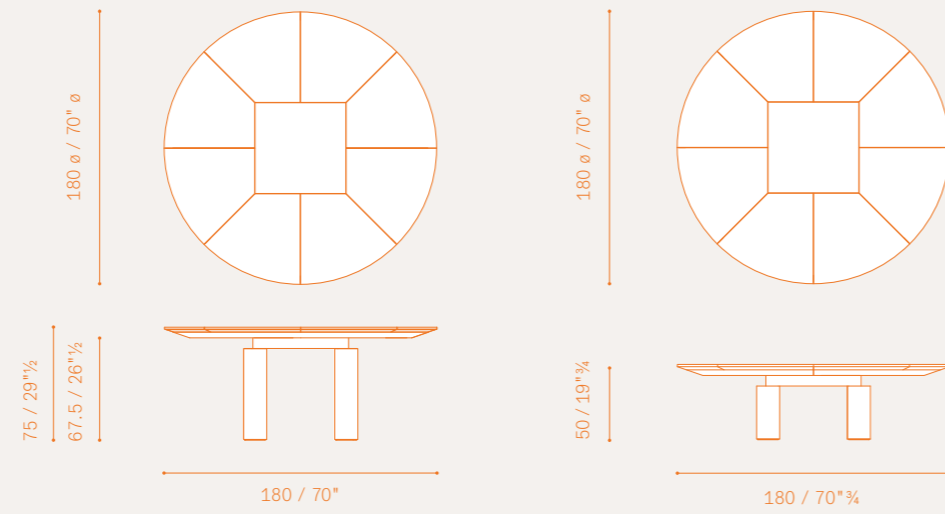

C.E.O. Cube Meeting Table Round meeting table ø 150 — Pelle Frau® SC leather

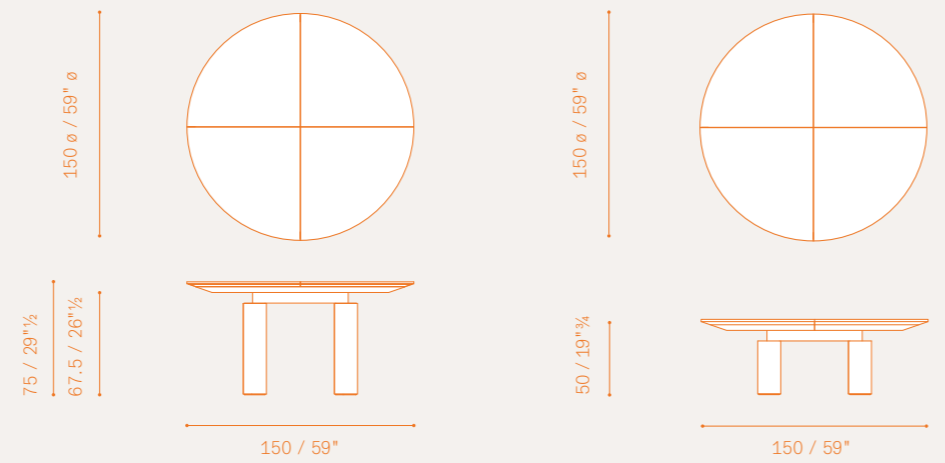

C.E.O. Cube Meeting Table Square meeting table — Pelle Frau® SC leather

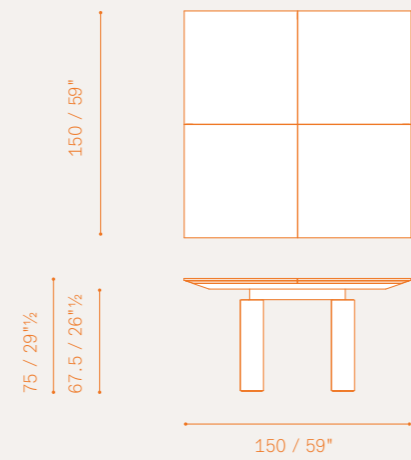

C.E.O. Cube Meeting Table 296x150cm Oval / Rectangular / with President Area — Pelle Frau® SC leather

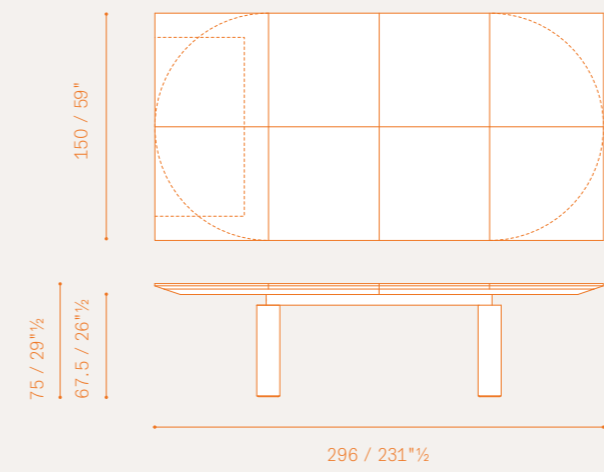

Hardware Versions Meeting Table

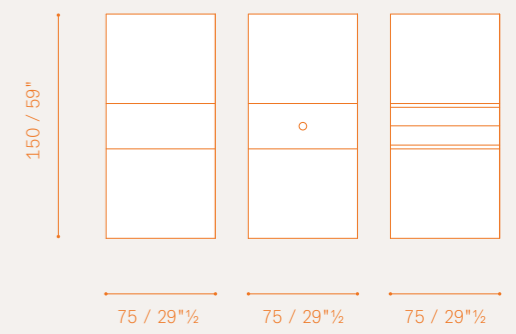

C.E.O. Cube Meeting Table 396x150cm Oval / Rectangular / with President Area — Pelle Frau® SC leather

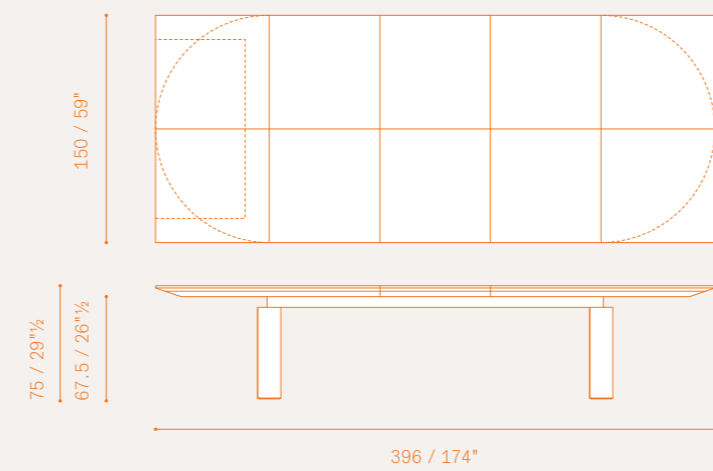

Hardware Versions Meeting Table

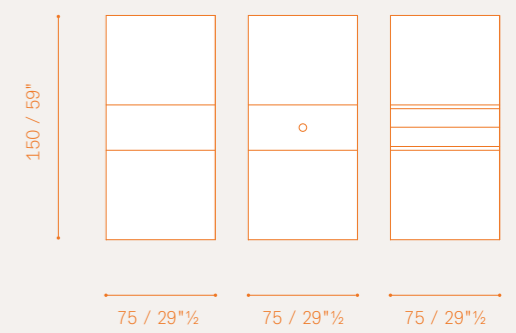

C.E.O. Cube Meeting Table 442x150cm Oval / Rectangular / with President Area — Pelle Frau® SC leather

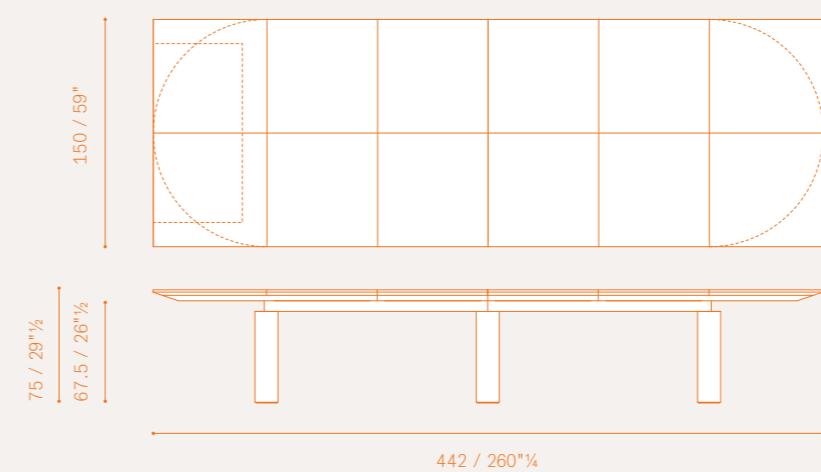

Hardware Versions Meeting Table

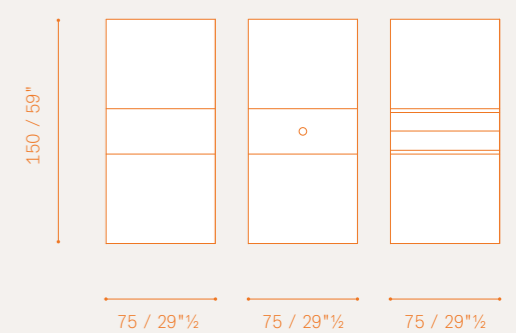

C.E.O. Cube Meeting Table 515x150cm Oval / Rectangular / with President Area — Pelle Frau® SC leather

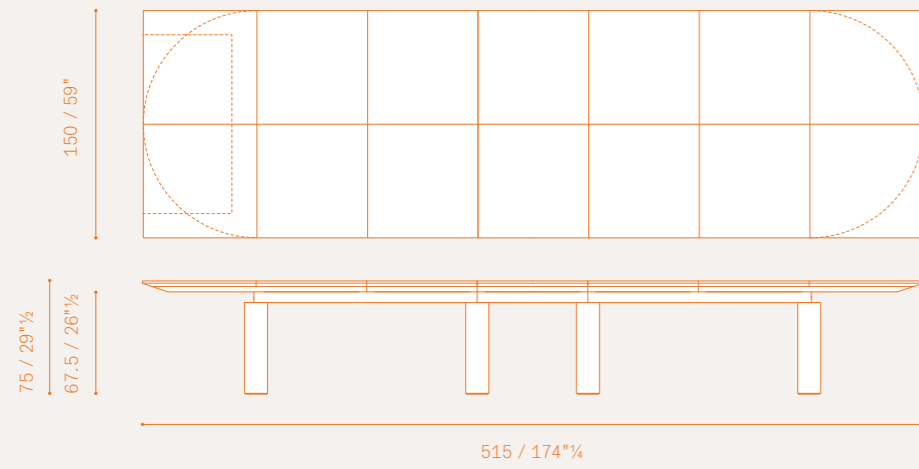

Hardware Versions Meeting Table

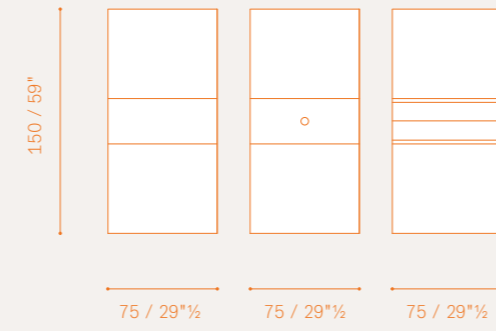

C.E.O. Cube Meeting Table 734x150cm Oval / Rectangular / with President Area — Pelle Frau® SC leather

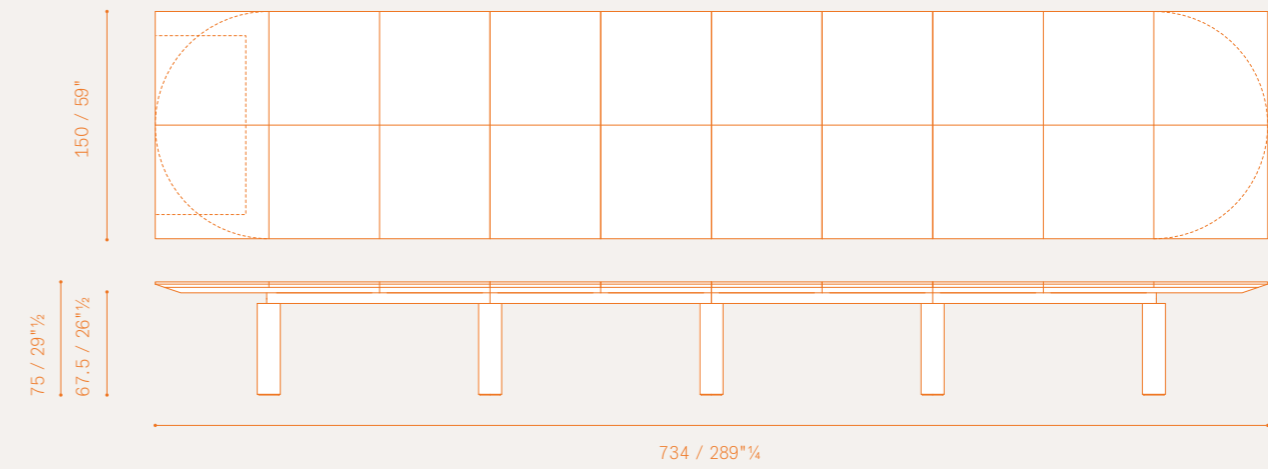

C.E.O. Cube Meeting Table 588x150cm Oval / Rectangular / with President Area — Pelle Frau® SC leather

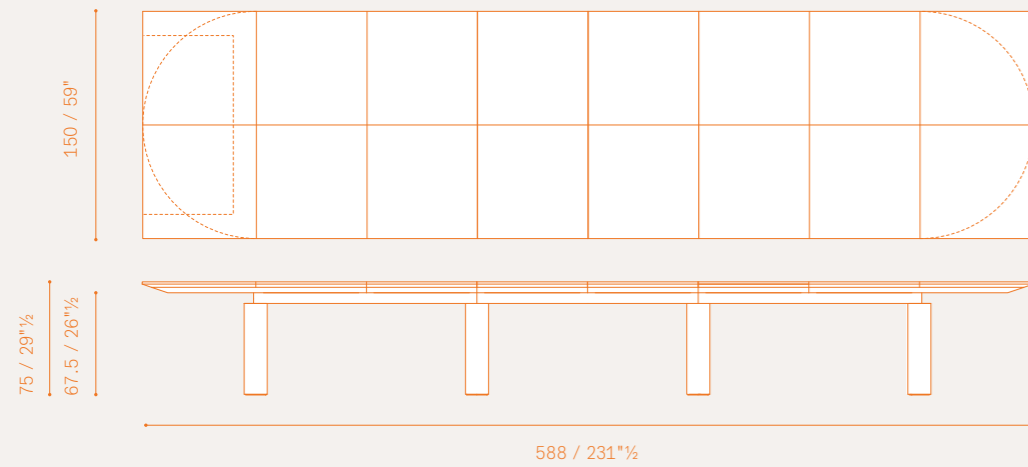

Hardware Versions Meeting Table

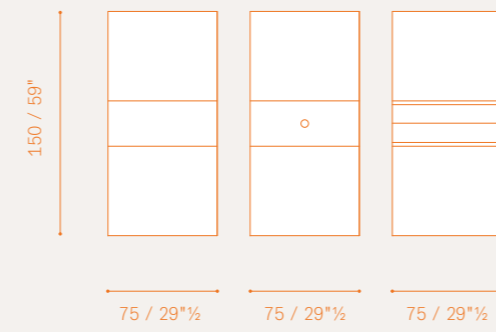

C.E.O. Cube Low Cabinet — Pelle Frau® SC leather / Small Cabinet — Pelle Frau® SC leather

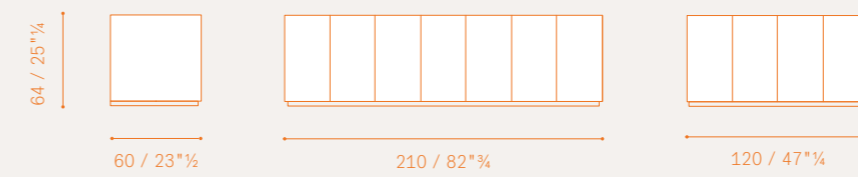

C.E.O. Cube Meeting Table 661x150cm Oval / Rectangular / with President Area — Pelle Frau® SC leather

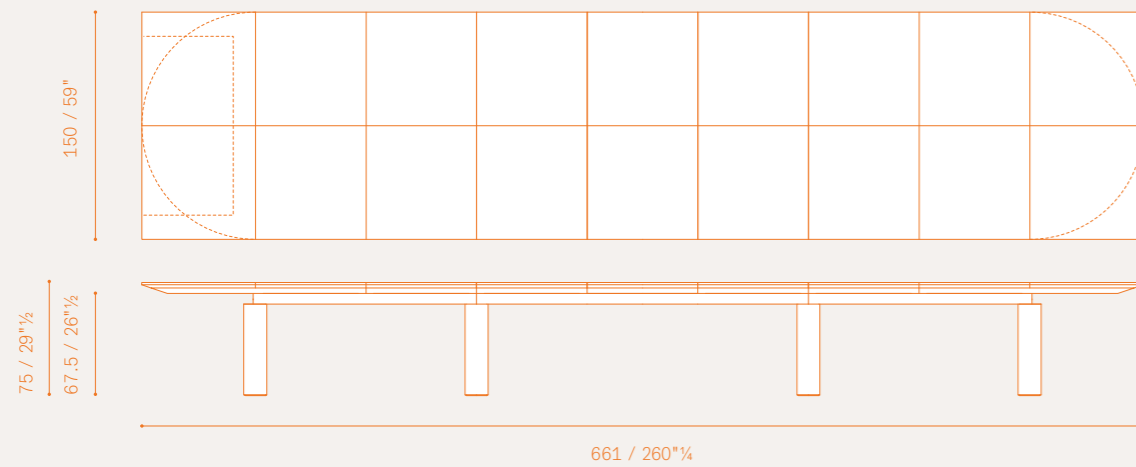

Hardware Versions Meeting Table

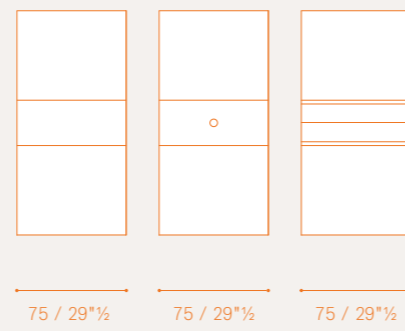

C.E.O. Cube Bookcase — Pelle Frau® SC leather

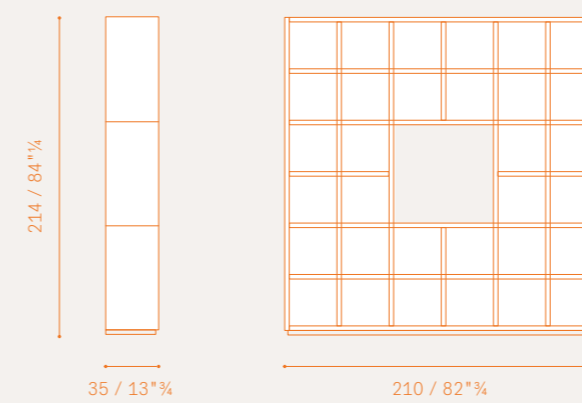

Claudio Silvestrin

H_0



CLAUDIO SILVESTRIN

Nato nel 1954, Claudio Silvestrin ha studiato a Milano e ha completato la sua formazione a Londra dove oggi lavora. Si occupa di interni domestici e commerciali, di musei e spazi espositivi e di design per brand prestigiosi. Il suo design austero, ma non estremo, contemporaneo e tuttavia senza tempo, persegue un minimalismo che non è uno stile, ma un modo di essere, una reazione forte al rumore e al disordine. Il suo lavoro è senza tempo, nobile e piacevole, intellettuale e sensibile, solare e tranquillo, attento alla perfezione di ogni dettaglio.

CONCEPT

Natura e design. Nuovi equilibri materici e un lusso mai ostentato. Incentrato sulla bellezza naturale di materiali della tradizione artigiana più antica, come pelle, pietra, legno e un design attento alle proporzioni armoniche fra le parti. Il programma H_0 rimanda a una rinnovata attitudine ad avere cura e piacere per la qualità unica di arredi esclusivi.

CLAUDIO SILVESTRIN

Born in 1954, Claudio Silvestrin studied in Milan and completed his training in London where he now works. He specialises in domestic and commercial interiors, museum and exhibition space interiors and designs for top brands. His designs, austere but not extreme, contemporary and yet timeless, pursue a form of minimalism. This is not really a style, but a modus operandi, a strong reaction to noise and chaos. His work is timeless, noble and pleasant, intellectual and sensitive, bright and calm, attentive to the perfection of every detail.

CONCEPT

Nature and design. New material balances and a luxury that is never ostentatious. Focused on the natural beauty of the most time-honoured materials of the artisanal tradition, such as leather, stone and wood, and designs that pay close attention to the harmonious proportions of the various elements. The H_0 programme is a return to taking care and pleasure in the unique quality of exclusive furnishings.

クラウディオ・シルヴェストリン

1954年生まれ。クラウディオ・シルヴェストリンはミラノで学んだ後、ロンドンで学業を終え、現在もロンドンで仕事をしている。住居や店舗のインテリア、ミュージアムや展示会場のデザイン設計、高級ブランドのためのデザインを手掛ける。装飾を抑えたデザインだが極端では無く、コンテンポラリーでありながらタイムレス。ミニマリズムを様式としてでは無く、騒音と無秩序への強い反発を示す生き方として追求している。シルヴェストリンの作品は

タイムレスで気品があり心地良く、知性的で感性豊か、明るくて落ち着きがあり、あらゆるディティールの完成度にこだわっている。

コンセプト

自然とデザイン。素材の新しいパランス、ひけらかさないラグジュアリー。レザー、石材、ウッドのような、古来の伝統工芸で使われて来た素材のナチュラルな美しさを活かし、デザインにおいては各部分が調和のとれた均衡を保つよう配慮する。H_0 プログラムは他に類を見ないほど質の高い家具を作るために手間をかけ、質の高さに喜びを見出す姿勢を新たに示す。

罗多尔夫・多尔多尼

Claudio Silvestrin 出生于 1954 年，曾就读于米兰，在伦敦完成训练指导课程并工作至今。他致力于家庭及商业室内空间设计、博物馆及展厅室内空间设计，并为众多一线品牌提供设计。他的设计风格质朴严肃，从不剑走偏锋，充满当代精神却又经得起时间考验，追求形式上的极简主义。这并非是一种风格，更像是一种特立独行的行为方式，对嘈杂混沌的强烈反应。他的作品是那样经典，高贵、令人愉悦；充满着睿智，明快，有一种让人平静的力量；对每一处细节都追求尽善尽美。

理念

自然与设计并存。新材料之间的相互平衡，营造出奢华却不浮夸的感觉。重点突出手工艺传统中那些历经时间洗刷的材质的自然之美，比如皮革，石头或木材，宣扬对于不同元素的应用比例拿捏得恰如其分的设计之美。H_0 项目是一种回归，对于与众不同的家具给予独一无二的品质关怀与用心。



↑ H_0 Executive Desk Lac, Pelle Frau® leather SC 30 Africa / Glossy bordeaux lacquered wood top / Slate column

Sistemi Direzionali — H_0

C.E.O. Office Furniture — H_0

エグゼクティブシステムズ — H_0

監 荷様准 鏡任所 — H_0



↑ H_0 Executive Desk Lac — Slate column ↗ Top and desk pad detail

Sistemi Direzionali — H_0

C.E.O. Office Furniture — H_0

エグゼクティブシステムズ — H_0

監 榎様 鎌 任 所 — H_0



↑ H_0 President Desk, dark version — Caffé Saddle Leather / Louro Preto / Valcamonica Porphyty

Sistemi Direzionali — H_0

C.E.O. Office Furniture — H_0

エグゼクティブシステムズ — H_0

監 梅様 鎌 任 所 — H_0

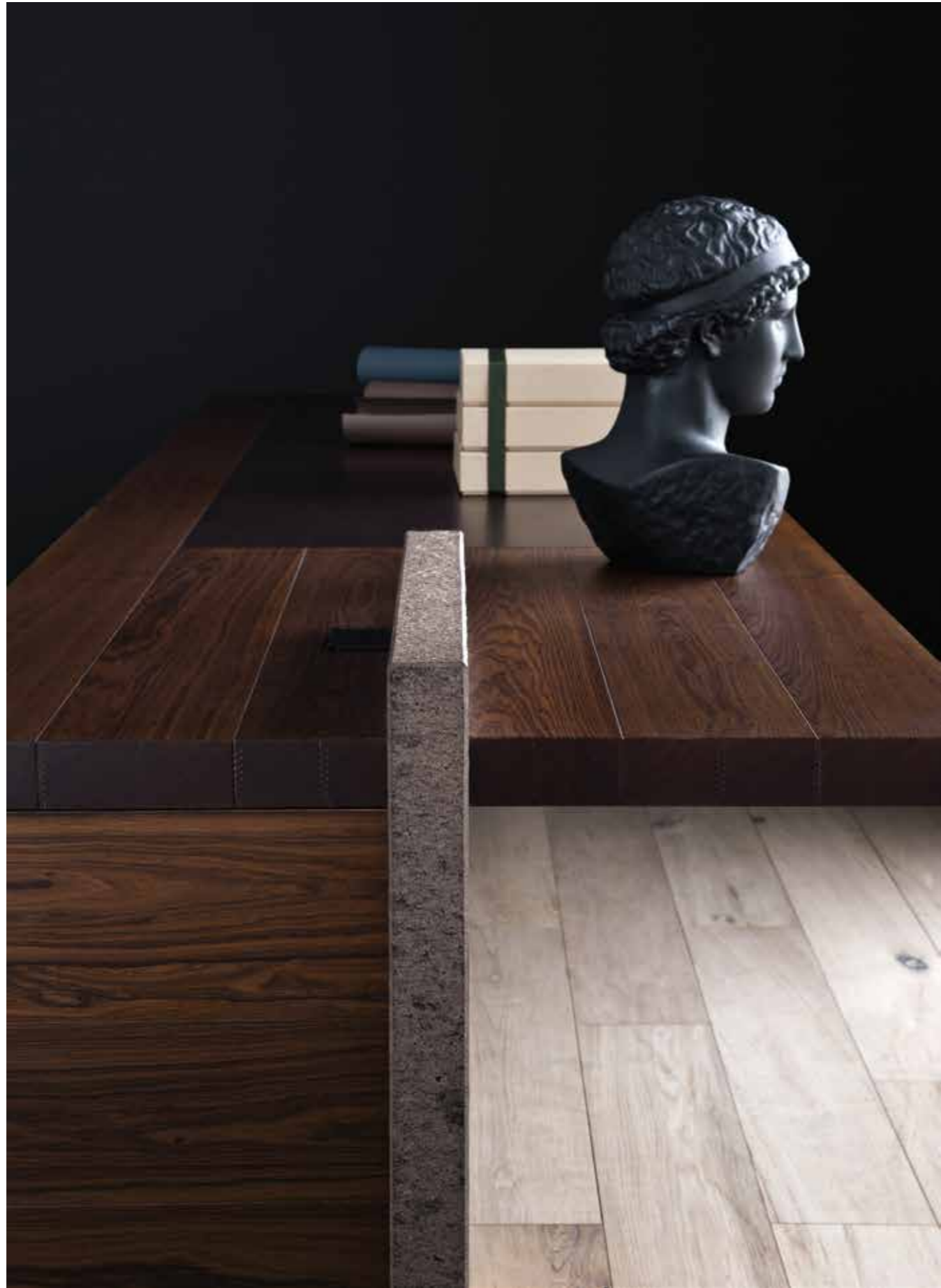

↑ H_0 President Desk — Valcamonica Porphyty column ↗ Drawer Unit



Sistemi Direzionali — H_0

C.E.O. Office Furniture — H_0

エグゼクティブシステムズ — H_0

監 柵様 濶 鎌 仟 折 — H_0

H_0 Materials

Il cuoio o la pelle, tre diverse tipologie di pietra, il legno, in essenza e laccato lucido. Scrivanie, tavoli riunione e mobili contenitori.

PELLE FRAU® COLOR SYSTEM E CUOIO SADDLE

La tattilità del cuoio, lavorato artigianalmente, si esprime nel pattern a quadri, “square”, ben visibile sui piani di tavoli e scrivanie e sulle facciate verticali di cabinet, consolle e libreria. Due i colori disponibili, Tortora e Caffè, anche nella versione “liscia”. La matericità della Pelle Frau® SC si manifesta invece nella versione “Lac” delle desk come rivestimento per sottomano e gamba di sostegno. Anche il cabinet può essere in pelle.

PORFIDO, TRAVERTINO E ARDESIA

La bellezza naturale del porfido si riconosce nelle colonne di sostegno di scrivanie e tavoli. Due le pietre utilizzate: Porfido Valcamonica, con colorazioni marrone/viola e Porfido Bianco, con colorazioni bianco/beige. L’eleganza della pietra ritorna anche nelle desk “Lac” con l’uso del Travertino bianco o dell’Ardesia per le colonne di sostegno.

ROVERE TORTORA, LOURO PRETO E LEGNO LACCATO LUCIDO

Le venature del legno, in tutti gli elementi del sistema, vengono proposte nelle due varianti, Rovere tortora per gli accostamenti con le tonalità chiare di cuoio e pietra, o Louro Preto nelle varianti scure della collezione. Nelle Desk “Lac” solo la cassetiera può essere scelta in essenza. Il piano di lavoro è in legno laccato bianco o nero lucidi in contrasto con il sottomano in pelle. A richiesta è possibile richiedere una laccatura lucida a campione.

皮革、三種の異なる石材、ウッドは木目仕上げと光沢ラッカー仕上げ。デスク、会議用テーブル、キャビネット類。

PELLE FRAU® COLOR SYSTEM ベツレフラウ®のカラーシステム CUOIO SADDLE クオイオ・サドル

テーブルやデスクの天板、キャビネット、コンソール、本棚の正面にはつきりと見て取れる“スクエア”のチェッカー・パターンを通して職人の技で鞣したレザーならではの風合いが表現力を発揮する。色は Tortora ダヴ・グレー と Caffè カフェの2色展開、“スムーズ”タイプのレザーでも同じ2色。Pelle Frau® ベツレ・フラウ®SCの素材感デスクの “Lac” ラックのタイプのデスクパッドや脚部のレザー張りでも活かされる。キャビネットもレザー張りが可能。

斑岩、トラバーチン、スレート

デスクやテーブルの支柱には斑岩のナチュラルな美しさが活かされる。使用される石材は 2 種類: Profido Valcamonica イタリアのカモニカ渓谷産の茶／紫色の斑岩および Profido Bianco 白／ベージュ色の白斑岩。“Lac” ラックのデスクでは Travertino bianco ホワイト・トラバーチンもしくは Ardesia スレートが支柱に使われ、石材のエレガンス際立つ。

ダヴグレー・オーク、ルーロプレト、光沢ラッカー仕上げのウッド

ウッドの木目はどのアイテムでも2色展開、レザーと石材の明るい色調に組合せるには Rovere Tortora ダヴグレー・オーク、また、コレクション中の濃い色調と組合せるなら Louro Preto ルーロプレト。“Lac” ラックのデスクでは引き出しにのみ木目仕上げを選ぶ。天板はウッドのホワイト・ラッカー光沢仕上げ、もしくは、ブラック・ラッカー光沢仕上げに、コントラストの組合せでレザーをデスクパッドに部分使いする。サンプルに則して光沢ラッカー仕上げを注文する事も可能。

皮革以及超厚皮革，3 种不同质地的石材，贴面为亮光烤漆或木饰面。有桌子，办公桌及其他家具单元组成。

从色彩系统中挑选的 PELLE FRAU® 皮革以及 CUOIO SADDLE 超厚皮革

无论是桌面或茶几台面 上显而易见的方形图案内，还是在橱柜，控制台或书柜的垂直面上，随时可以感受到手工打磨的原皮触感。有两种颜色 - 驼色或咖啡色 - 同样也有“光滑”的皮革套面款式可供挑选。于此同时，对于 Pelle Frau® SC 皮革的触感来自 “Lac” 款式办公桌的前端，用该皮革包裹桌面的办公区域及桌腿。储物单元也同样软包皮革。

斑岩、孔石及板岩

斑岩的自然之美从办公桌与茶几的支撑立柱上可见一斑。这其中，运用了两种斑岩：棕色或紫色的为火山斑岩，而呈现出白色或米色的部分则运用了白斑岩。石材的优雅也体现在 “Lac” 款式的办公桌的选材上，其支撑立柱采用了白色的孔石或板岩。

灰色橡木，柏图木以及亮光烤漆木饰面

家具系统中的所有元素都包含两种不同的木质纹理，灰白色的橡木与色调明快的皮革或石头组合运用，而深色纹理的柏图木则与系列中其他深色元素搭配。在 “Lac” 办公桌的款式中，只有斗柜单元能选择木质。工作台表面为白色烤漆或黑色亮光木饰面，与皮革软包的工作区域形成视觉对比。这块区域同样也能根据要求以高光烤漆处理。



H_0 President Desk

La versione scura delle desk H_0, nelle foto, presenta la gamba e il sottomano in Cuoio Saddle "square" color Caffè, il piano e la cassetiera in Louro Preto e la colonna in Porfido Valcamonica.

In the photos the dark version of the H_0 desks, has Caffè-coloured "square" Cuoio Saddle leather leg and desk pad, top and chest of drawers in Louro Preto and a Valcamonica Porphyry column.

H_0 デスクのダーク・カラーのタイプ、写真の製品は脚部とデスクパッドが Cuoio Saddle クアイオ・サドルの"スクエア"で色は Caffè カフェ、天板と引き出しは Louro Preto ルーロプレト、支柱は Profido Valcamonica カモニカ溪谷産斑岩。

图示为深色款的 H_0 桌，咖啡色的方形桌腿包裹 Cuoio Saddle 超厚皮革，桌面的工作区域，顶面，以及斗柜都采用了柏图木，以及火山斑岩支柱。

Nelle versioni "square" il rivestimento base è realizzato con un motivo "tono su tono" a scacchi di 16×16 cm. Il pannello di cortesia, optional, è sempre in Cuoio Saddle liscio abbinato.

In the "square" versions, the basic cover includes a 16×16 cm "ton sur ton" chessboard motif. The optional modesty panel is in matching Cuoio Saddle leather, always in the smooth variant.

"スクエア"のタイプでは、ベースは"トーン・オン・トーン" 16×16 cm のチェッカー・モチーフでレザーが張られており、使用者の脚を隠すためのレザー張りのパネルはオプションで、スムーズの Cuoio Saddle クアイオ・サドルで色をコーディネート。

在方形的款式中，16×16 cm 见方的跳色棋盘格构成了最基本的图案。可另外添置的私密活动挡板为了搭配 Cuoio Saddle 超厚皮革，总是采用光滑的纹理。



H_0 President Desk Lac

La Desk "Lac" nella foto presenta il piano in legno laccato lucido bianco in contrasto al sottomano in Pelle Frau® SC 30 Africa con colonna in Ardesia e cassetiera in essenza di Louro Preto. Anche la gamba è in Pelle Frau® SC30 Africa.

The "Lac" Desk in the photo has a white gloss lacquer wood top which contrasts with the Pelle Frau® leather SC 30 Africa desk pad with Slate column and drawer unit in Louro Preto. The leg is also in Pelle Frau® leather SC 30 Africa.

"Lac" ラックのデスクの写真では、天板はウツドのホワイト・ラッカー光沢仕上げ、デスクパッドは Pelle Frau® ペッレ・フラウ® SC 30 Africa アフリカ色でコントラスト、支柱は Ardesia スレート、引き出しは Louro Preto ルーロプレト。脚部も Pelle Frau® ペッレ・フラウ® SC 30 Africa アフリカ色。

图中的 "Lac" 办公桌拥有白色亮光烤漆的木质台面，与用 SC 30 Africa Pelle Frau® 皮革软包的工作区域形成鲜明的色彩对比，板岩支撑柱，以及用柏图木打造的抽屉单元。桌腿同样采用 SC 30 Africa Pelle Frau® 皮革软包。

La cassetiera di tutte le Desk H_0, normale e "Lac", può essere posta a destra o a sinistra rispetto alla posizione del fruitore ed è attrezzabile con un cassetto e un vano sportello, in alternativa, un classificatore.

The drawer unit of all of the H_0 Desks, both normal and "Lac", can be placed to the right or left of the user and is equipped with a drawer and a cabinet or, alternatively, a filing cabinet.

標準のものも "Lac" ラックも、すべての H_0 デスクの引き出しは使用者から見て右側にも左側にも配置する事ができ、引き出し一つにキャビネット、もしくは、整理箱をつける事ができる。

H_0 办公桌的斗柜单元，无论是通常款还是 "Lac" 款，都可以根据需要安置于用户的左手或右手边；标配一个抽屉，一个储物柜，后者也可以替换为一个档案柜。

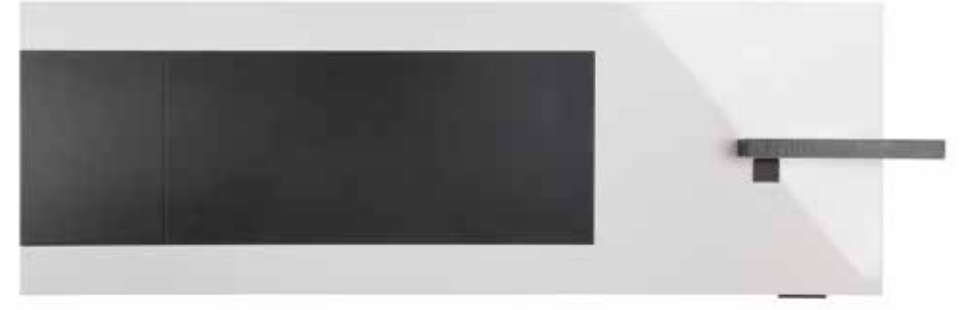

H_0 Executive Desk

La versione chiara delle desk H_0 prevede il sottomano e la gamba in Cuoio Saddle color Tortora, liscio o "square", il piano e la cassettera in Rovere Tortora e la colonna in Porfido bianco.

The light version of the H_0 desks have desk pad and leg in smooth or "square" Tortora-coloured Cuoio Saddle leather top and drawer unit in Ash-Tinted Oak and column in White Porphyry.

H_0 デスクのライト・カラーのタイプでは、Tortora ダヴ・グレー色のスムーズもしくは"スクエア"の Cuoio Saddle クオイオ・サドルをデスクパッドと脚部に使う。天板と引き出しは Rovere Tortora ダヴグレー・オーク、支柱は Profido Bianco 白斑岩。

H_0 办公桌的的浅色款拥有光滑或带有方形图案的驼色 Cuoio Saddle 超厚皮革包裹的工作区域或桌腿，顶面以及抽屉单元采用灰色橡木打造，白斑岩支柱。

Il pannello di cortesia, optional, è sempre in cuoio liscio abbinato.

The optional modesty panel is always in matching smooth saddle leather version.

使用者の脚を隠すためのパネルはオプションで、コーディネイト・カラーのスムーズ・レザー張り。

可另外添置的私密活动挡板总是能搭配光滑的 Saddle 超厚皮革。



H_0 Executive Desk Lac

La Desk "Lac" nella foto presenta il piano in legno laccato lucido a campione, qui in RAL 3004, con sottomano e gamba di appoggio in Pelle Frau® SC 26 Topo e colonna in Ardesia.

The "Lac" Desk in the photo has a gloss lacquer wood top according to sample, here in RAL 3004 with desk pad and supporting leg in Pelle Frau® leather SC 26 Topo and Slate column.

写真の "Lac" ラックのデスクの天板はサンプルにある光沢ラッカー仕上げのウッド、この場合は RAL 3004、デスクパッドと脚部は Pelle Frau® ペッレ・フラウ SC 26 Topo トープ色のレザー張り、支柱は Ardesia スレート。

图示中的 "Lac" 办公桌根据样品应为高光烤漆木质桌面，而此处的办公区域采用了 RAL 3004，支撑腿包裹 Pelle Frau® SC 26 Topo 皮革，采用板岩支撑立柱。

La cassettera è in Louro Preto e posizionata a destra rispetto alla posizione del fruitore.

The drawer unit is in Louro Preto and placed to the right of the user.

引き出しは Louro Preto ルーロプレト、使用者から見て右側に配置される。

柏图木打造的抽屉单元置于用户的右手边。





Dettaglio della borchia passacavi che permette ai cavi elettrici di salire dalla colonna sino al piano di lavoro.

Detail of the grommet of the cable tidy that rises from the column up to the desktop.

電気の配線を支柱から天板に通す金具のディテール。

细节图: 带金属垫圈的电线收纳管通过支撑柱通往桌面。

H_0 President Desk Lac — Dettaglio tecnico del passaggio cavi — Technical details of the cable passage — ケーブル配線に関する技術的詳細 — 电缆管道的技术细节



H_0 Executive Desk Lac — Dettaglio tecnico del passaggio cavi — Technical details of the cable passage — ケーブル配線に関する技術的詳細 — 电缆管道的技术细节

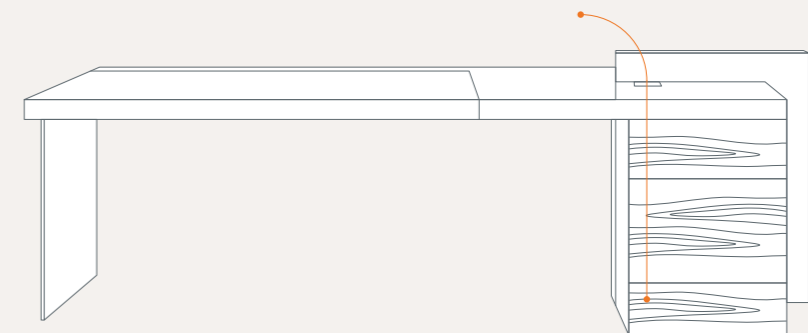

H_0 Low Round Meeting Table ø 160cm h 50cm

La versione scura del tavolo basso H_0, nelle foto, presenta il piano in Cuoio Saddle "square" color Caffè, gambe di appoggio in Louro Preto e colonna in Porfido Valcamonica. I round table sono disponibili anche nella versione in Cuoio Saddle liscio.

In the photos the dark version of the H_0 low round table has a Caffè-coloured "square" Cuoio Saddle leather top, supporting leg in Louro Preto and column in Valcamonica Porphyry. The round tables are also available in the smooth Cuoio Saddle leather version.

H_0,ロー・テーブルのダーク・カラーのタイプ、写真の天板は Cuoio Saddle クオイオ・サドル"スクエア"のカフェカフェ色レザー張り。脚部は Louro Preto ルーロプレト、支柱は Porfido Valcamonica カモニカ溪谷産斑岩。ラウンド・テーブルは Cuoio Saddle クオイオ・サドルのスムーズ・レザー張りのタイプも有る。

图示款为深色 H_0 圆形矮桌，咖啡色“方形”图案 Cuoio Saddle 超厚皮革软包桌面，桌脚由柏图木制成，支撑柱为火山斑岩。圆桌另有一款光滑 Cuoio Saddle 超厚皮革的款式可供选择。



H_0 Round Meeting Table ø 203cm h 72cm

La versione scura del tavolo riunione rotondo, nelle foto, ha il piano in Cuoio Saddle "square" color Caffè, gambe di appoggio in Louro Preto e colonna in Porfido Valcamonica. I round table sono disponibili anche nella versione in Cuoio Saddle liscio.

In the photos the dark version of the round meeting table has a Caffè-coloured "square" Cuoio Saddle leather top, supporting legs in Louro Preto and column in Valcamonica Porphyry. The round tables are also available in the smooth Cuoio Saddle leather version.

会議用ラウンド・テーブルのダーク・カラーのタイプ。写真の天板は Cuoio Saddle クオイオ・サドル"スクエア"のカフェカフェ色レザー張り、脚部は Louro Preto ルーロプレト支柱は Porfido Valcamonica カモニカ溪谷産斑岩。ラウンド・テーブルは Cuoio Saddle クオイオ・サドルのスムーズ・レザー張りのタイプも有る。

图示款为深色 H_0 圆形会议桌，咖啡色“方形”图案 Cuoio Saddle 超厚皮革软包桌面，桌脚由柏图木制成，支撑柱为火山斑岩。圆桌另有一款光滑 Cuoio Saddle 超厚皮革的款式可供选择。

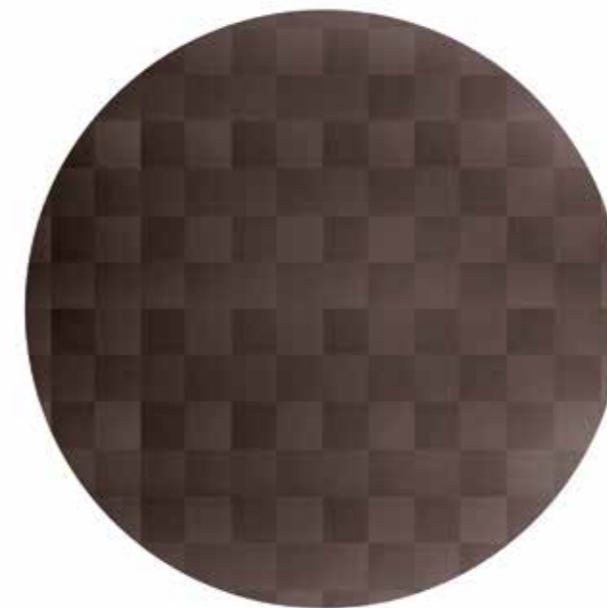

H_0 Oval Meeting Table

La versione scura del tavolo riunione ovale, nelle foto, ha il piano in Cuoio Saddle "square" color Caffè e gambe di appoggio in Louro Preto.
La versione chiara abbina invece al piano in Cuoio Saddle color Tortora, liscio o "square", gambe in Rovere tortora. Sulla parte centrale del piano è prevista la possibilità di ricavare 4 vani apribili per accogliere eventuali impianti elettrici.

In the photos the dark version of the oval meeting table has a Caffè-coloured "square" Cuoio Saddle leather top and supporting legs in Louro Preto. Meanwhile, the light version pairs Ash-Tinted Oak legs with Tortora-coloured smooth or "square" Cuoio Saddle leather. Four openable compartments can be made in the central part of the surface to accommodate electrical wiring.

会議用オーバル型テーブルのダーク・カラーのタイプ。写真の天板は Cuoio Saddle クオイオ・サドル"スクエア"の Caffèカフエ色レザー張り。脚部は Louro Preto ルーロプレト。ライト・カラーのタイプの天板は Cuoio Saddle クオイオ・サドルの Tortora ダヴ・グレーのスムーズ・レザー、もしくは、"スクエア"レザーで張る。脚部は Rovere tortora ダヴグレー・オーク。天板のセンター部分に電気の配線を通すスペースが 4 か所開ける様に設計されている。

图示款为深色 H_0 椭圆形会议桌，咖啡色“方形”图案 Cuoio Saddle 超厚皮革软包桌面，桌脚由柏图木制成。同时，另有浅色款搭配灰色橡木桌腿，及光滑驼色皮革或“方形”图案 Cuoio Saddle 超厚皮革。



H_0 Console

Nella foto la versione scura della Consolle H_0 che abbina il Cuoio Saddle "square" color Caffè all'essenza di Louro Preto.

The photo shows the dark version of the H_0 Console Table, which combines Caffè-coloured "square" Cuoio Saddle leather and essence of Louro Preto.

写真は H_0 コンソールのダーク・カラーのタイプで、Cuoio Saddle クオイオ・サドル"スクエア"の Caffè カフエ色と Louro Preto ルーロプレトのコンビネーション。

图示款为深色 H_0 蜗形腿小桌，结合了咖啡色方形图案 Cuoio Saddle 超厚皮革，与柏图木的精美细节。



H_0 Cabinet Lac / Cabinet

Il cabinet H_0 è disponibile in Pelle Frau® del Color System, in abbinamento alle Desk Lac, o in cuoio Saddle, sia liscio che "square". Nelle foto al lato è presentato nella versione in Pelle Frau® SC 26 Topo e in Cuoio Saddle "square" Caffè, sempre in abbinamento al legno Louro Preto. Il cabinet è attrezzato con quattro cassetti e quattro vani dotati di anta e attrezzati internamente con mensole.

The H_0 cabinet is available in Pelle Frau® Color System, matched to the Desk LAC, or both in smooth and "square" Cuoio Saddle leather. The photos show the Pelle Frau® SC 26 Topo version and the dark one in Caffè-coloured "square" Cuoio Saddle leather, both matched with Louro Preto wood. The cabinet comes with four drawers and four compartments with doors, and has shelves inside.

H_0 のキャビネットは Lac ラックのデスクとコーディネートして Color System カラー・システムの Pelle Frau® ペッレ・フラウ® でレザー張り、あるいは、Cuoio Saddle クオイオ・サドルのスムース、もしくは、"スクエア"でも可能。横の写真では、Pelle Frau® ペッレ・フラウ® SC 26 Topo トーポ、および Cuoio Saddle クオイオ・サドルの"スクエア"の Caffè カフェ色、組み合わせるのは常に Louro Preto. ルーロプレートの木目仕上げ。キャビネットには引き出しが 4 つと扉付のコンパートメントが 4 つ付いており、その内部には棚がついている。

从色彩系统中精选光滑或"方形"图案的 Pelle Frau® 皮革或 Cuoio Saddle 超厚皮革软包可供挑选。图示为深色款储物柜。咖啡色"方形"图案 Cuoio Saddle 超厚皮革搭配柏图木。储物柜包含 4 个抽屉以及 4 个带柜门的单元格，内部自带搁板。



H_0 Modular Bookcase

La libreria, componibile, si basa sulla combinazione di tre elementi base, cassetto, colonna e mensola che possono dare origine a configurazioni differenti. Quattro dimensioni disponibili, tutte configurabili nelle versioni chiara o scura.

Nella foto la versione scura della bookcase lunga 400 cm che abbinata il Cuoio Saddle "square" color Caffè, usato per i frontali, al legno Louro Preto usato per la struttura.

The modular bookcase is based on the combination of three basic elements - drawer, column and shelf which can be configured in different ways. Four sizes available, all configurable in the light or dark versions. The photo shows the dark version of the 400 cm-long bookcase that pairs the Caffè-coloured "square" Cuoio Saddle leather used for the front with the Louro Preto wood used for the structure.

ユニット式本棚は引き出し、支柱、棚という 3 つの基本要素から成り、組合せ方によって形状を変えられる。4 種類のサイズがあり、それぞれのサイズにライト・カラーのタイプとダーク・カラーのタイプがある。写真は 400 cm の本棚のダーク・カラーのタイプ。Cuoio Saddle クオイオ・サドル"スクエア"の Caffè カフェ色をフロント面に使い、Louro Preto ルーロプレートを構造に使う組合せ。

常规款书架由 3 个基本元素组成——抽屉、支撑柱及搁板架——这些元素相互之间可以变换出无穷组合方式。有 4 种大小尺寸可供选择，所有组合件均可选择深色或浅色款式。图示为深色款的 4 米长书柜，正面使用咖啡色"方形"图案 Cuoio Saddle 超厚皮革，而结构框架则采用了柏图木打造。



H_0 President Desk — Saddle or Saddle Square leather

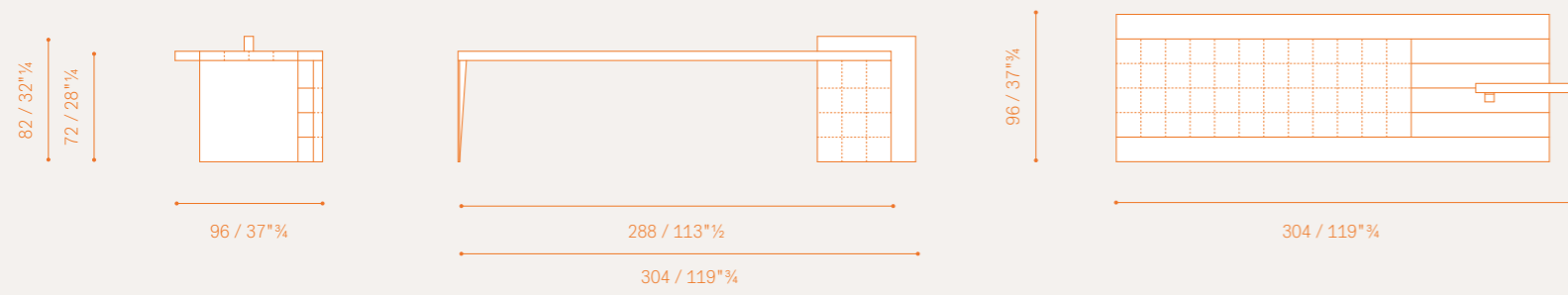

H_0 President Desk — with modesty panel — Saddle or Saddle Square leather

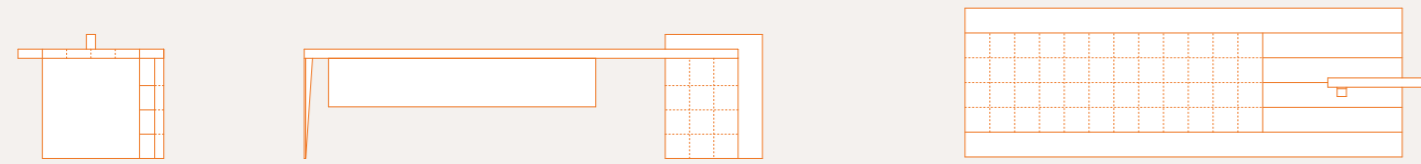

H_0 President Desk Lac — Pelle Frau® SC leather

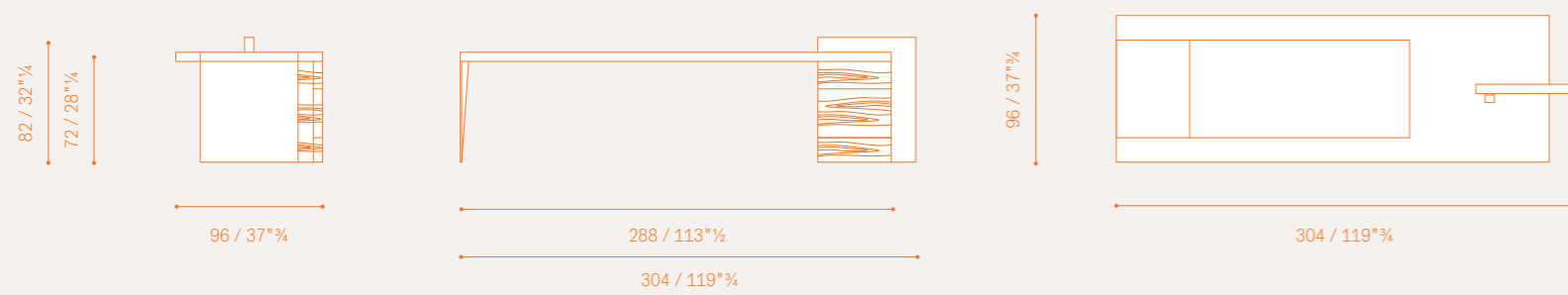

H_0 President Desk Lac — with modesty panel — Pelle Frau® SC leather

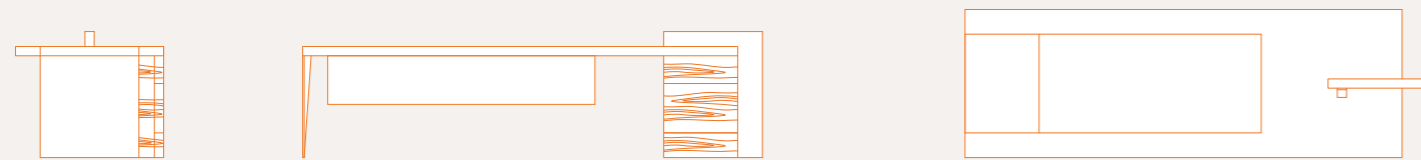

H_0 Executive Desk — Saddle or Saddle Square leather

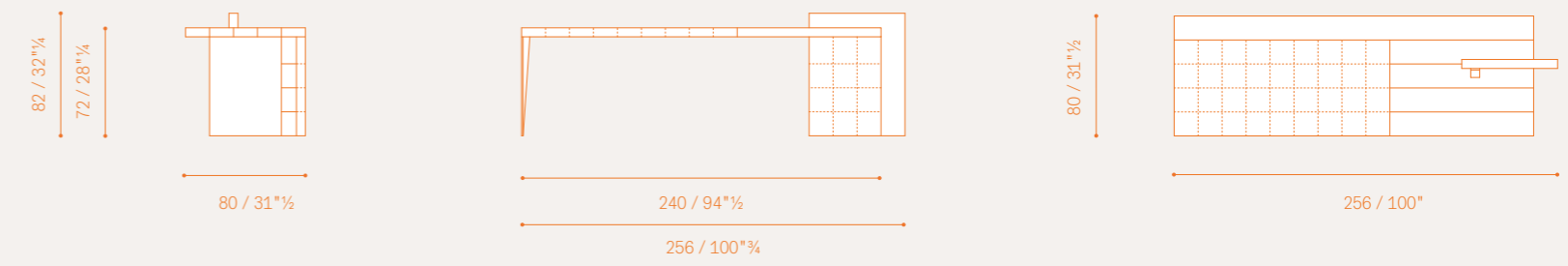

H_0 Executive Desk — with modesty panel — Saddle or Saddle Square leather

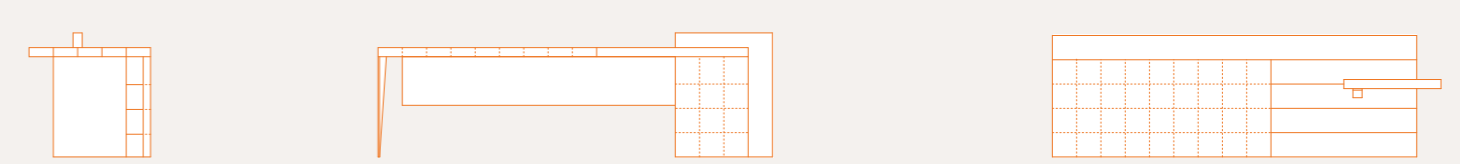

H_0 Executive Desk Lac — Pelle Frau® SC leather

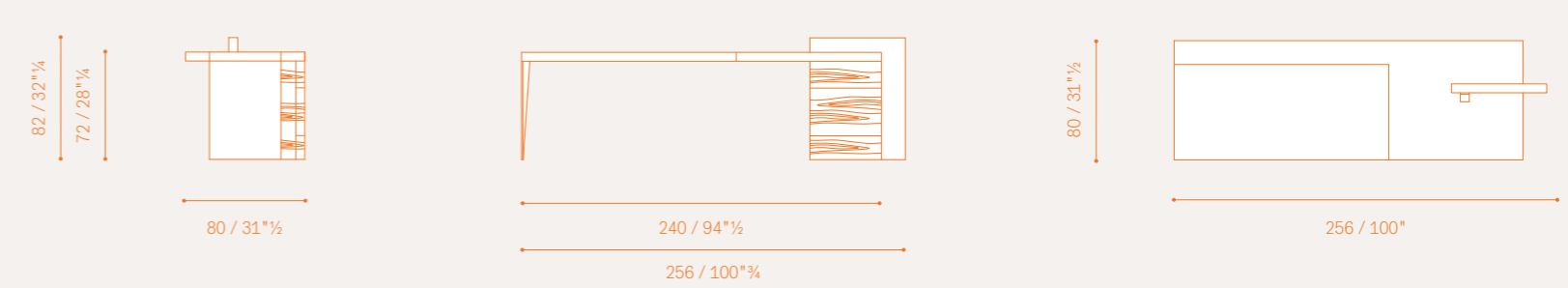

H_0 Executive Desk Lac — with modesty panel — Pelle Frau® SC leather

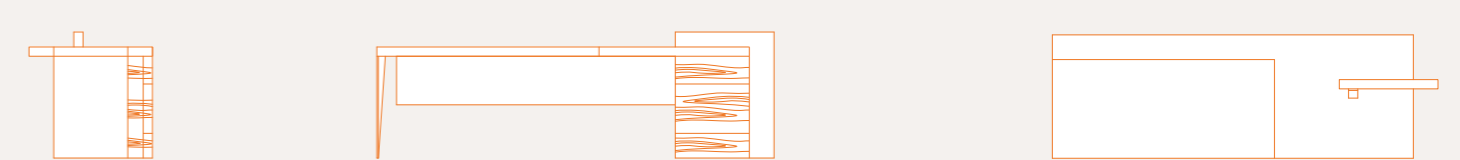

H_O PC Table — Saddle or Saddle Square leather

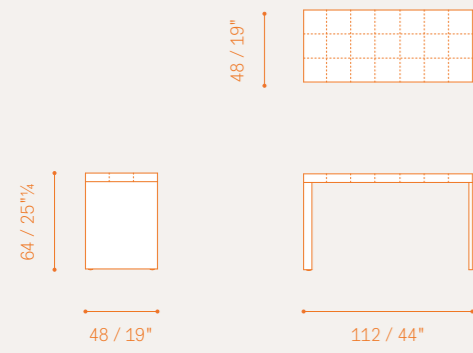

H_O Console — Saddle or Saddle Square leather

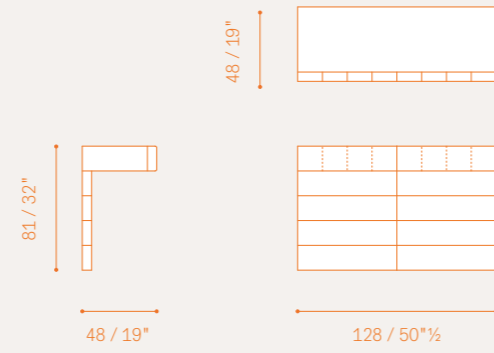

H_O Low Round Meeting Table — Saddle or Saddle Square leather

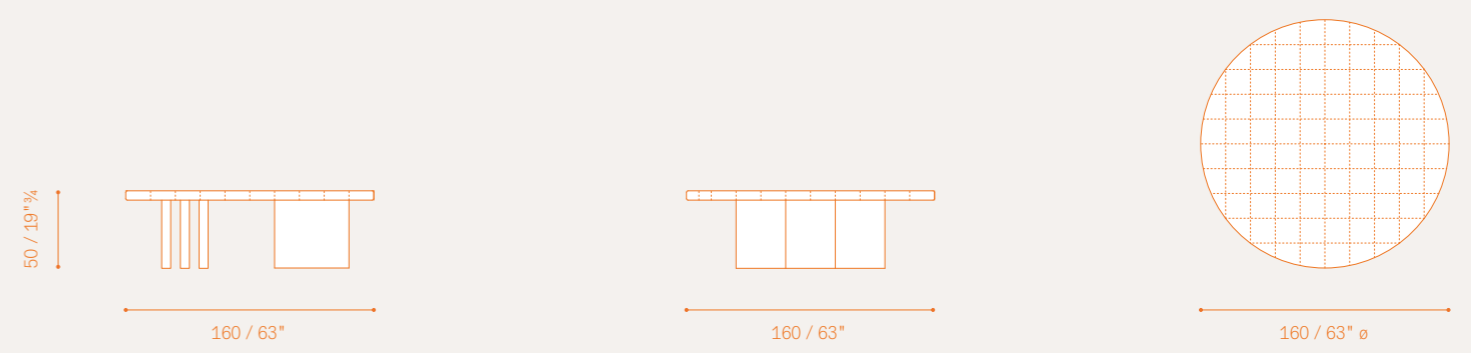

H_O Cabinet — Saddle or Saddle Square leather

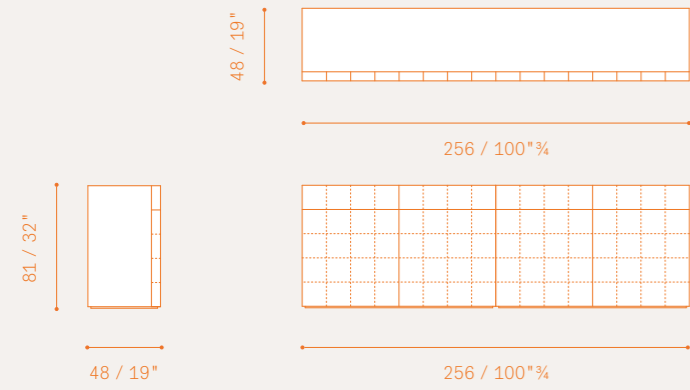

H_O Cabinet Lac — Pelle Frau® SC leather

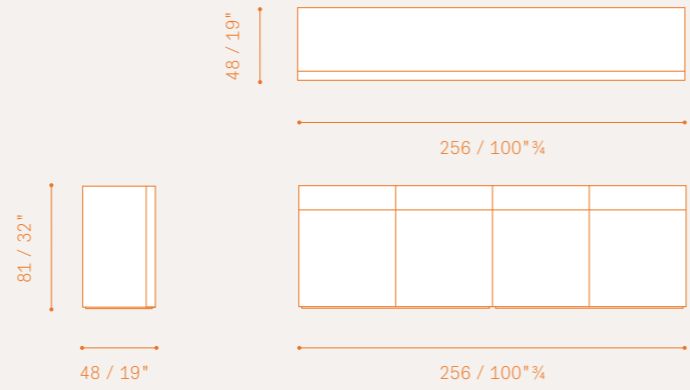

H_O Round Meeting Table — Saddle or Saddle Square leather

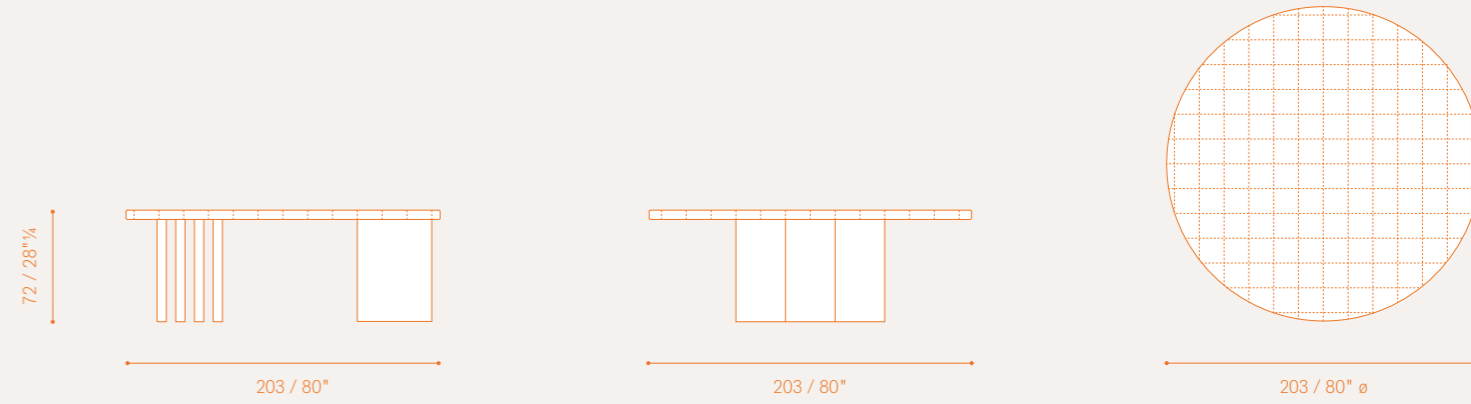

H_O Bookcase 145x208 / 145x272 / 145x336 / 145x400 — Saddle or Saddle Square leather

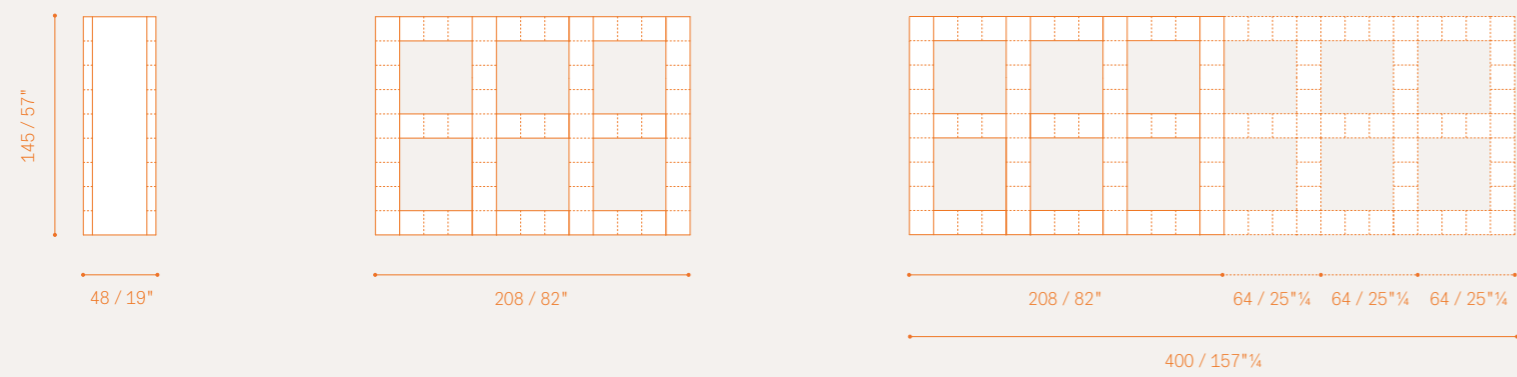

H_O Oval Meeting Table / H_O Oval Meeting Table Hardware — Saddle or Saddle Square leather

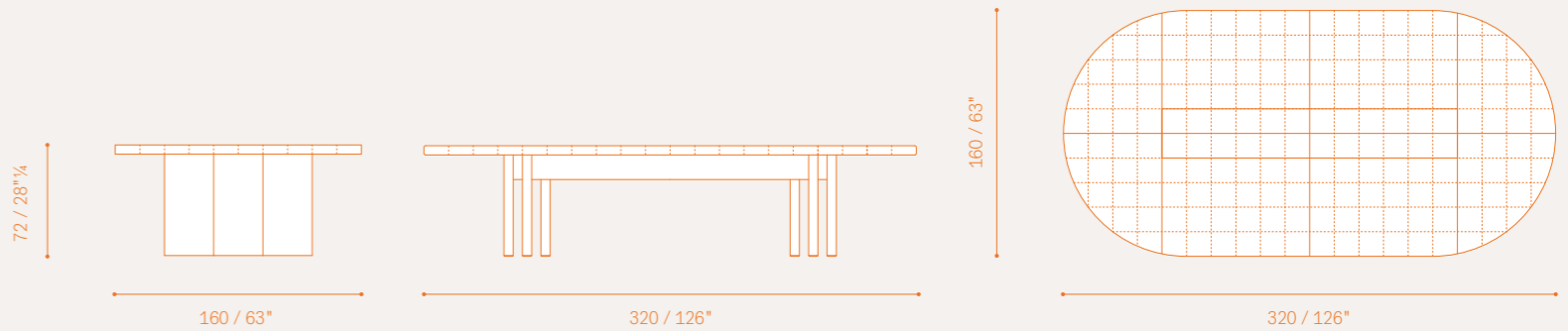

Luca Scacchetti

Corinthia



LUCA SCACCHETTI

Nato a Milano nel 1952 si è laureato in architettura al Politecnico di Milano. Le sue prime realizzazioni, agli inizi degli anni Ottanta, sono ristrutturazioni e costruzioni di case per abitazioni in Lombardia, Svizzera e Germania. Nel 1985, a Milano, si occupa della ristrutturazione di un edificio in corso Garibaldi; in seguito realizza un doppio edificio per abitazione in viale Piave (1986-90). A Roma ha realizzato il ridisegno del terminale internazionale di Fiumicino. Ha partecipato a concorsi per edifici e spazi pubblici e ha realizzato numerosi progetti d'interni per abitazioni, uffici, negozi ed esposizioni. Ha disegnato mobili, oggetti decorativi e tessuti. Ha partecipato a esposizioni in Italia e all'estero ed è stato relatore in congressi internazionali.

CONCEPT

Libertà assoluta nell'uso della forma, cercando di restare lontano dal razionalismo asciutto che contraddistingue molti degli arredi dell'ufficio di prestigio.

ルカ・スカッケッティ

1952年ミラノに生まれる。ミラノ理工科大学建築学部卒業。1980年初頭からロンバルディア州、スイス、ドイツで、邸宅の修復や新築。1985年にミラノで、コロソ・ガリバルディ通りの建物を修復、その後、

ヴィアーレ・ピアヴェ通りに二棟で

一軒の邸宅を建造(1968~90年)。

ローマのフィウミチーノ空港国際線

ターミナルのリニューアル。公共の建

造物や公共スペースの国際コンペに

参加、住宅、オフィス、店舗、展示会な

どの内装設計も数多く手がける。家

具、インテリア装飾用オブジェ、テキ

スタイルをデザイン。イタリア内外の

展示会にも参加、国際会議の壇上に

招かれる事も多い。

コンセプト

高級オフィス家具に有りがちな合理主義とは距離を置き、全く自由にフォルムを操る。

LUCA SCACCHETTI

Lucca Scacchetti 1952年出生于米兰,毕业于米兰理工大学的建筑系。他的职业生涯始于二十世纪80年代,包括在意大利伦巴第地区,瑞士与德国等地修复与新造建筑。1985年,他主持了米兰加里波第大道上的建筑的重修工作。接着又接手了米兰Viale Piave地区一幢双体住宅楼的建造工作(1986-90)。他曾重新设计了罗马菲乌米奇诺机场的国际航站楼,参与各类建筑大楼,公共空间的设计竞标,为众多室内设计项目,无论是家庭,办公场所,抑或是商店或展览,交出优秀设计。他也曾设计过家具,装饰配件与布艺织物。他参加过意大利国内及海外多个展览,并受邀在国际峰会上发表演讲。

理念

对于外形的完全自由发挥,避免奢华办公场所常见的形而上学的形式主义室内设计通病。

LUCA SCACCHETTI

Born in Milan in 1952, Lucca Scacchetti graduated in architecture from the Politecnico di Milano. His early work at the start of the 1980s included restorations and new houses in Lombardy, Switzerland and Germany. In 1985, he took charge of the restoration of a building in Corso Garibaldi in Milan. He then went on to complete a dual residential building in Viale Piave (1986-90). He redesigned the international terminal at Rome Fiumicino Airport and has taken part in competitions for buildings and public spaces, performing a great many interior design projects for homes, offices, shops and exhibitions. He has designed furniture, decorative objects and fabrics. He has taken part in exhibitions in Italy and abroad and has been a speaker at international conferences.

CONCEPT

Absolute freedom in the use of form, seeking to avoid the dry rationalism that characterises much interior design in luxury offices.



↑ Corinthia Desk with 3 drawers, Pelle Frau® leather SC 3 Grigio

Sistemi Direzionali — Corinthia

C.E.O. Office Furniture — Corinthia

エグゼクティブシステムズ — Corinthia

監 梅様 鎌任 仝 — Corinthia



↑ Corinthia Desk with 3 drawers — Turned Column detail ↗ Drawer Unit

Sistemi Direzionali — Corinthia

C.E.O. Office Furniture — Corinthia

エグゼクティブシステムズ — Corinthia

豎 柵 様 漣 鑲 仟 仞 — Corinthia

Corinthia Materials

Acciaio, legno, pelle e cristallo si fondono nella ricchezza delle geometrie di una collezione unica completa di tavoli, scrivanie e mobili contenitori formalmente molto connotati.

ACCIAIO CROMATO

Struttura in acciaio cromato: eleganti volute che richiamano le geometrie classiche della colonna e del capitello corinzio. Un profilo curvo in acciaio a “v” che, funziona sia come punto di appoggio dei piani che come piede o sostegno per mobili e cassettiere. Le colonne tornite in acciaio cromato hanno il “capitello” reggipiano in estruso di alluminio lucidato e costituiscono i sostegni portanti di scrivanie e tavoli riunione.

NOCE CANALETTO

Usato in abbinamento o in alternativa alla pelle, il noce Canaletto può essere scelto per impreziosire il piano di lavoro delle desk diversificando le fasce laterali dal sottomano in pelle ma anche come finitura dei meeting table in una vastissima varietà di combinazioni con pelle e cristallo. I cabinet, se scelti nella versione pelle/legno, hanno frontali e top in essenza.

PELLE FRAU® COLOR SYSTEM

La Pelle Frau® riveste l’area di lavoro del piano di scrivanie e meeting table, tutta, in parte o semplicemente il bordo perimetrale dei piani. Corinthia è disponibile anche con colonne di sostegno a sezione quadrangolare rivestite in pelle. Anche nei cabinet la pelle può rivestire piano e frontali o solamente il bordo perimetrale del top.

CRISTALLO TRASPARENTE

Esclusivo per i meeting table ovali, il cristallo trasparente può essere usato nella parte centrale del piano in abbinamento a pelle e/o noce Canaletto dando vita ad un’ampia gamma di combinazioni materiche.

Steel, wood, leather and glass are combined in the rich geometries of a unique collection of tables, desks and furniture units that are highly distinctive from a formal point of view.

CHROME-PLATED STEEL

Chrome-plated steel structure: elegant swirls that recall the classic geometries of columns and Corinthian capitals. A v-shaped curved steel profile that functions as both a support for the surfaces and as a foot or support for furniture units or drawer chests. The chrome-plated steel turned columns have “capital” brackets in polished extruded aluminium and bear the weight of the desks and meeting tables.

CANALETTO WALNUT

Canaletto walnut is used together with or as an alternative to leather to embellish desktops, distinguishing the lateral edges from the leather desk pad, but also as a finish for the meeting tables in a vast range of combinations with leather and glass. The fronts and tops of the cabinets in the leather/wood version, are in wood.

PELLE FRAU® LEATHER FROM THE COLOR SYSTEM

Pelle Frau® leather completely or partially covers the worktop of the desk or meeting table, or is used just around the edges. Corinthia is also available with quadrangular supporting columns covered in leather. Leather can also be used to cover the top and fronts of the cabinets or, alternatively, just the edges of the top.

TRANSPARENT GLASS

Transparent glass is used exclusively for the oval meeting tables. It can be used in the central part of the tabletop together with leather and/or Canaletto walnut to create to a wide range of material combinations.

独特のフォルムのテーブル、デスク、キャビネットなど、様々な形状からなるユニークなコレクションの中で、スチール、ウッド、レザー、クリア・ガラスなどの素材が見事に融合。

クロム・コートのスチール

クロム・コートを施したスチールの支柱:コリント式柱頭や柱に見られる古典的な造形を彷彿させる優美なカーブ。輪郭が“V”字型のスチールは天板を支えると同時に、家具や引き出しの脚や支えとしての機能も果たす。旋盤成形にクロム・コートを施したスチール製支柱には“柱頭”があり、押し出し成形アルミ製光沢仕上げの柱頭はデスクや会議用テーブルの支えとなる。

NOCE CANALETTO

カナレット・ウォールナット

Noce Canaletto カナレット・ウォールナットはレザーとのコンビネーション、もしくは、レザーの代わりに使われる。デスクの天板に高級感を与えるこの素材をレザーのデスクパッドの両サイドに使い、特徴を出す事もできる。また、会議用テーブルの仕上げに、レザーやクリア・ガラスとのコンビネーションの選択肢も豊富に提案されている。キャビネット類についてはレザー／ウッドのタイプを選んだ場合、フロント面と天板は木目となる。

PELLE FRAU® COLOR SYSTEM

ペルレ・フラウ®カラー・システム

Pelle Frau® ペルレ・フラウ® はデスクと会議用テーブルの天板の革張りに使われる。全体に革張りを施す場合もあれば、部分使い、あるいは、天板の縁取りだけにレザーを使う場合もある。Corinthia は断面が四角い支柱に革張りしたものもある。キャビネットについても、天板とフロント面両方を革張り、あるいは、天板の縁取りだけをレザーにする事も可能。

クリア・ガラス

会議用テーブルのオーバル型のみ特別に、クリア・ガラスを天板のセンター部分に使ってレザーおよび／もしくは、Noce Canalettoカナレット・ウォールナットとのコンビネーションが可能で、素材の組合せの選択肢が豊富。

钢材、木材、皮革与玻璃通过丰富的几何形式组合在一起,创造出与众不同的茶几、书桌与家具系列,独特的外形打破了传统的定义。

CHROME-PLATED STEEL

镀铬的不锈钢金属结构: 优雅的螺旋底座不禁让人联想起经典的几何形立柱以及科林斯式的柱头.V型弯曲既可以作为台面的功能性支撑结构,同时也作为家具单元和斗柜的支撑脚。镀铬不锈钢为螺旋立柱的主体材质,而柱头部分则采用 抛光轧制铝,以承担办公台与会议桌的重量。

CANALETTO WALNUT CANALETTO 胡桃木

Canaletto 胡桃木既可以与皮革拼在一起,或与皮革单独使用,作为桌面的装饰,使侧边缘与皮革的办公区域形成鲜明对比,也可以作为会议桌众多皮革与玻璃材质组合饰面中的一种形式。储物柜正面与顶面包裹皮革/木质的款式,为实木打造。

从色彩系统中精选的 PELLE FRAU® 皮革

办公桌或会议桌的工作区域可以选择全部或部分由 Pelle Frau® 皮革包裹,或者仅用来包裹边缘。科林斯式的元素同样运用于四棱支撑柱上,外面包裹皮革。皮革也可以用于储物柜的顶面或正面,或者围绕顶面边缘一圈。

透明玻璃

透明玻璃材质特别用于椭圆形的会议桌。这种材质可以用于桌面的中央区域,搭配皮革以及/或 Canaletto 胡桃木,共同营造出丰富的材质搭配。

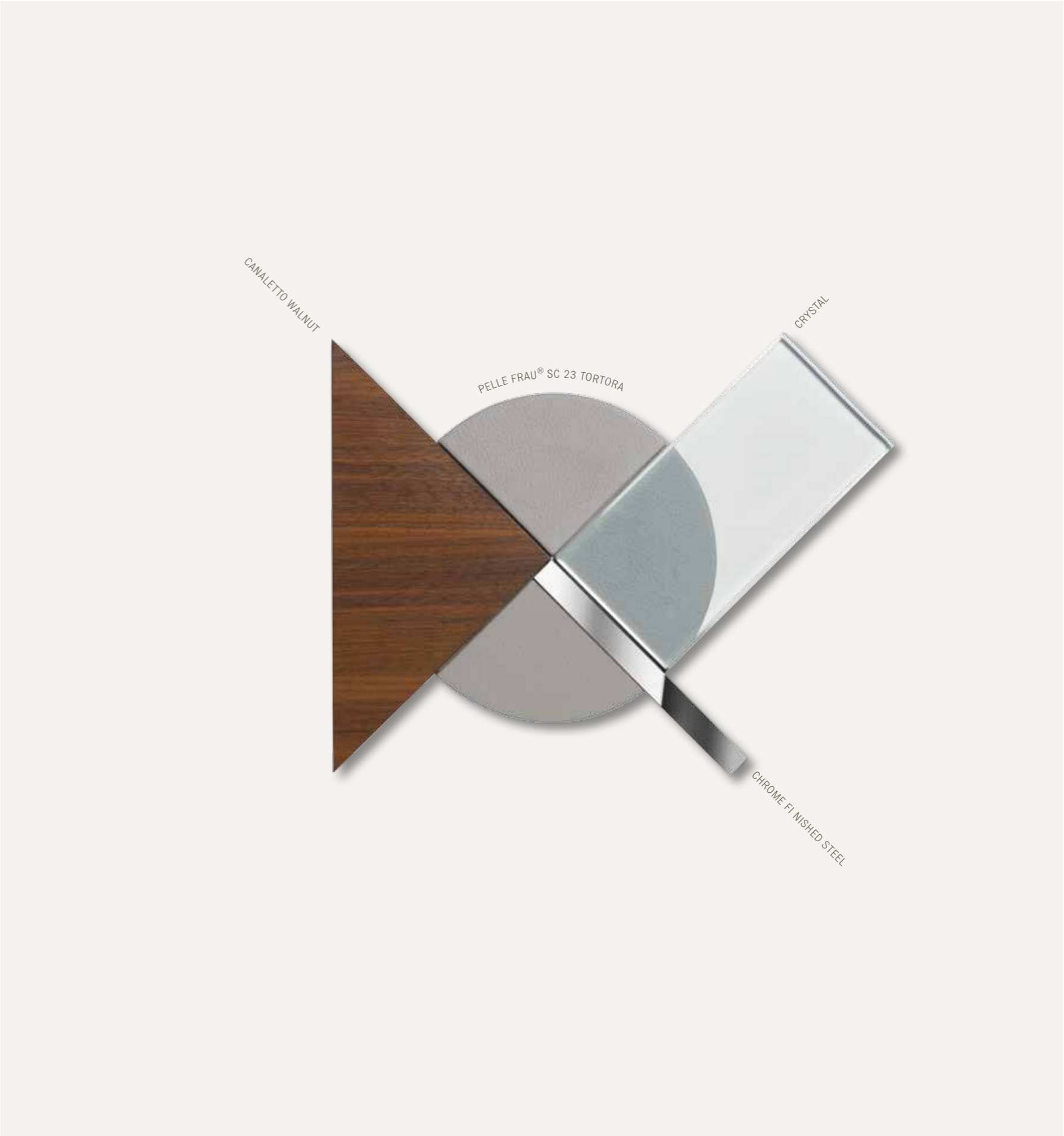

Corinthia Desk

Il piano di lavoro è composto da quattro pannelli in fibra di legno a media densità, i cui due laterali possono essere impiallacciati in noce Canaletto mentre i due centrali sono sempre rivestiti in Pelle Frau®. I bordi perimetrali sono rivestiti in pelle. Nelle foto il piano è interamente rivestito in Pelle Frau® SC 3 Grigio. La cassetteria della scrivania è dotata di 3 cassetti muniti di serratura con frontali e retro completamente rivestiti in pelle in abbinamento al piano.



The top surface is made up of four panels of medium-density wood fibre. The two side pieces can be in Canaletto walnut veneer while the two centre pieces are always upholstered in Pelle Frau® leather. Top has leather-covered edges. In the photo It's entirely upholstered in Pelle Frau® leather SC 3 Grigio. The drawer unit has three lockable drawers with front and back completely covered in leather to match the top.

作業台は4枚のMDF中密度繊維版で構成され、両サイドの2枚はNoce Canaletto カナレット・ウォールナットの木目仕上げも可能、センターの2枚は常にPelle Frau® ベッレ・フラウ®のレザー張り。縁取りは常にレザー。写真の製品は、Pelle Frau® ベッレ・フラウ® SC 3 Grigio グレーで全体をレザー張り。デスクには錠付の引き出しが3つ備わっており、フロント面と裏面はデスクの天板とのコーディネートで全面レザー張り。



桌面由4块中密度嵌纤维板拼接而成。两侧的两块板可以选用Canaletto胡桃木贴皮。而中间的两块板只能选用Pelle Frau®皮革软包。桌面边缘采用皮革围边。图示款为完全采用Pelle Frau®皮革系列中的SC 3 Grigio套面软包的款式。抽屉单元包含3个带锁的抽屉。正面及背面都采用完全皮革包裹。与桌面的选材相互呼应。

Corinthia Easy Desk

Nelle foto il piano ha i pannelli centrali in Pelle Frau® SC 238 Blu Notte e i pannelli laterali in Noce Canaletto. Le scrivanie possono avere come sostegni portanti colonne tornite in acciaio cromato con capitello (come nella foto) o colonne quadrangolari rivestite in pelle.



In the photos top surface has central panels in Pelle Frau® SC leather 238 Blu Notte and lateral panels in Canaletto Walnut veneer. The desks can be supported by turned chrome finished steel columns with capitals (as in the photo) or square leather columns.

写真の製品では、天板のセンターのパネルがPelle Frau® ベッレ・フラウ® SC 238 Blu notte ナイト・ブルーのレザー張り、サイドのパネルはNoce Canaletto カナレット・ウォールナット。デスクの支柱は旋盤で成形してクロム・コートを施したスチールに柱頭がついた支柱(写真の通り)、あるいは、レザー張りで断面が四角い支柱の使用も可能。

图示款的桌面,位于中间的两块嵌板包裹Pelle Frau® SC系列中的238 Blu Notte皮革。而侧翼的两块嵌板则采用Canaletto胡桃木贴皮工艺。桌面支撑采用镀铬表面的不锈钢螺旋支柱,上端带有装饰柱头(如图所示)或者采用皮革包裹的方形四棱柱。



Corinthia Modular Meeting Table

I tavoli ovali, disponibili in numerose dimensioni, sono modulari. Nella foto il piano è rivestito in Pelle Frau® SC 23 Tortora con parte centrale in cristallo trasparente.

The oval tables, available in various sizes, are modular. In the photo the top is covered in Pelle Frau® leather SC 23 Tortora with the central part in transparent glass.

オーバル型のテーブルはサイズが豊富で、ユニット式。写真の製品の天板は Pelle Frau® ベッレ・フラウ® SC 23 Tortora クレイ色のレザー張りで、センターの部分がクリア・ガラス製。

标准款的椭圆形桌子,有多种尺寸可供挑选。图示款中的桌面为包裹 Pelle Frau® 系列的 SC 23 Tortora 皮革,中央的部分拼接透明玻璃材质。



Il piano dei tavoli riunione è retto da una struttura in acciaio cromato dotata di "capitelli" reggipiano e colonne di sostegno.

The meeting table surface is supported by a chrome-plated steel structure with "capital" brackets and supporting columns.

会議用テーブルの天板はクロム・コートを施したスチールの上に“柱頭”がついた支柱で支えられている。

会议桌的表面由镀铬得不锈钢结构支撑,带有柱头样式的托架与支撑柱。

Corinthia Modular Meeting Table

Nella foto il piano è in noce Canaletto con parte centrale in cristallo trasparente e bordo in pelle.

In the photo the top is in Canaletto walnut veneer with the central part in transparent glass and leather-covered edges.

写真の製品の天板は Noce Canaletto カナレット・ウォールナットで、センターの部分がクリア・ガラス製、縁取りはレザー。

图示款的桌面,四周为 Canaletto 胡桃木贴皮,中央部分为透明玻璃拼接,四周采用皮革围边。

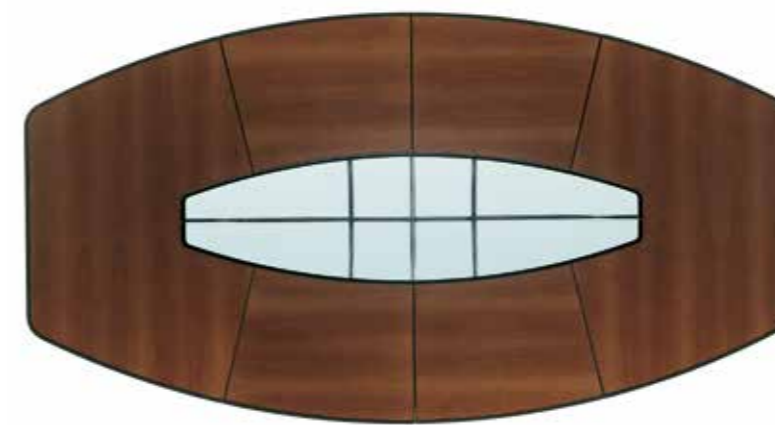

Nella foto il piano è rivestito in Pelle Frau® SC 23 Tortora con parte centrale in noce Canaletto e bordo in pelle.

In the photo the top is covered in Pelle Frau® leather SC 23 Tortora with the central part in Canaletto walnut veneer and leather-covered edges.

写真の製品は天板が Pelle Frau® ベッレ・フラウ® SC 23 Tortora クレイ色のレザー張りで、センターの部分は Noce Canaletto カナレット・ウォールナット、縁取りはレザー。

图示款的桌面,四周为 Pelle Frau® 系列的 SC 23 Tortora 皮革软包,中央部分采用 Canaletto 胡桃木贴皮,四周采用皮革围边。



Corinthia Modular Meeting Table

Ogni posto di lavoro è delimitato sul piano da pannelli in fibra di legno a media densità rivestiti in pelle o impiallacciati in noce canaletto con bordo in pelle. Nella foto il piano è rivestito in Pelle Frau® SC 53 Creta con parte centrale in cristallo trasparente.

Each workspace on the table surface is defined with MDF panels. They are covered with leather or veneered with Canaletto walnut veneer with leather trim. In the photo the top is covered in Pelle Frau® leather SC 53 Creta with the central part in transparent glass.

天板上でそれぞれの仕事のスペースは、レザー張りの MDF 中密度繊維版、もしくは、Noce Canaletto カナレット・ウォールナット木目仕上げにレザーの縁取りが施された MDF 中密度繊維版で区分されている。写真の製品の天板は Pelle Frau® ベッレ・フラウ® SC 53Creta クレイ色のレザー張りで、センターの部分がクリア・ガラス製。

桌面上的的每一块工作区域都设计采用 MDF 嵌板。每一块嵌板都包裹皮革或采用 Canaletto 胡桃木贴皮交织细条皮革编织带。图示款的桌面，四周为 Pelle Frau® 系列的 SC 53 Creta 皮革软包，中央部分采用透明玻璃。



Corinthia Round Table

Tavolo rotondo Ø 150 cm rivestito in Pelle Frau® del Color System, nella foto SC 128 Carminio. Il piano di lavoro è composto da 6 pannelli che possono essere impiallacciati in noce canaletto, con rifinitura in pelle lungo i bordi perimetrali e nel disco centrale, o interamente rivestiti in Pelle Frau®. Struttura portante composta di elementi tubolari in acciaio e appoggiata su colonne in acciaio cromato.

Ø 150 cm round table covered in Pelle Frau® leather from the Color System, in the photo SC 128 Carminio. The table top comprises six panels that can either be covered with Canaletto walnut veneer, with leather trim along the edges and the central disc, or completely covered in Pelle Frau® leather. The supporting frame is composed of tubular steel elements and supported by columns in chrome-plated steel.

Color System カラー・システムの Pelle Frau® ベッレ・フラウ® でレザー張りした 150cm 径の丸テーブル。写真の製品のレザーの色は SC 128 Carminio カルミン・レッド。天板は 6 枚のパネルで構成され、Noce Canaletto カナレット・ウォールナット木目仕上げ、縁取りとセンターの円盤型にレザーの部分使いが可能。あるいは、全体を Pelle Frau® ベッレ・フラウ® でレザー張りする事もできる。天板を支える構造はスチール製パイプで構成され、クロム・コートを施したスチール製の支柱に乗っている。

直径 150cm の圆形桌包裹从色彩系统中精选出的 Pelle Frau® 皮革。图示款为 SC 128 Carminio 皮革。桌面由 6 块嵌板组成，饰面既可以选择 Canaletto 胡桃木贴皮，边缘及中央圆盘位置采用细条皮革编织带，或者也可以选择完全包裹 Pelle Frau® 皮革。支撑结构由不锈钢管元素组成，采用镀铬不锈钢柱状支撑。

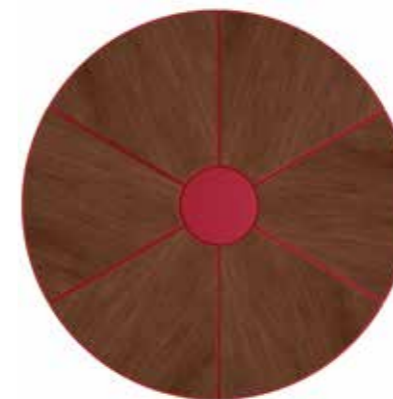



Colonne di sostegno opzionali: colonna tornita in acciaio cromato o colonna quadrangolare rivestita in Pelle Frau® del Color System.

Optional supporting columns: turned column in chrome-plated steel or square column covered with Pelle Frau® leather from the Color System.

支柱のオプション: 旋盤で成形してクロム・コートを施したスチール製の支柱、もしくは、Color System カラー・システムの Pelle Frau® ペッレ・フラウ® でレザー張りした断面が四角い支柱。

其他可选择的支撑柱: 镀铬的不锈钢螺旋支柱或是包裹从色彩系统中精选的 Pelle Frau® 皮革的四方立柱。

I tavoli riunione ovali utilizzano come struttura portante colonne, tornite o quadrangolari, sormontate da un "capitello" reggipiano in estruso di alluminio lucidato e raccordate tramite elementi curvi in tubolare metallico.

The oval meeting tables are supported by turned, or square, columns and topped by a "capital" bracket in polished extruded aluminium, connected using curved tubular metal elements.

オーバル型会議用テーブルには旋盤で成形した支柱、もしくは、断面が四角い支柱が使われ、さらに、押し出し成形光沢仕上げのアルミニウム製「柱頭」がカーブした金属パイプで連結されている。

椭圆形会议桌可选择螺旋支撑

Corinthia Drawers Unit

Il rivestimento di top, retro e frontali è sempre in Pelle Frau® SC, nella foto SC 3 Grigio. Disponibile nelle versioni a 3 cassetti o a 1 cassetto e 1 classificatore, entrambe munite di serratura centralizzata, la cassettera è dotata di quattro ruote piroettanti.

The top, front and rear are all covered with Pelle Frau® SC leather, in the photo SC 3 Grigio. Available in versions with three drawers or one drawer and one filing cabinet, both with central keyhole, the drawers chest has four swivel castors.

天板、裏面、フロント面のレザー張りは常に Pelle Frau® ベッレ・フラウ® SC、写真の製品のレザーの色は SC 3 Grigio グレー。引き出し 3 つのタイプ、もしくは、引き出し 1 つに整理箱のタイプ。両方ともセンターロックが付いている。引き出しのキャビネットは 4 本のキャスター付き。

頂面、正面及背面均采用 Pelle Frau® SC 系列皮革包裹，图式款采用的是 SC 3 Grigio 皮革。有带三个抽屉的款式，或带一个抽屉及一个文件抽的款式可供选择，任何一种款式都配备中央锁孔，斗柜下有四个旋转脚轮。



Corinthia Low Cabinet 285cm / 194cm

Due dimensioni, da 285 cm e da 194 cm, entrambe disponibili nelle versioni in Pelle Frau® SC o in Noce Canaletto con bordi perimetrali in pelle. Nelle foto SC 57 Torba. I piani intermedi dei vani a giorno sono realizzati in cristallo trasparente sagomato per accogliere le colonne in acciaio tornito. I vani dotati di anta sono muniti di serratura con chiave.

Two sizes, 285 cm and 194 cm, both available in the versions with Pelle Frau® leather from the Color System or Canaletto walnut veneer with leather trim. In the images, SC 57 Torba. The intermediate levels of the open compartments are in transparent glass shaped to accommodate the turned steel columns. The compartments with doors are equipped with lock and key.

285 cm と 194 cm という二つのサイズ。両サイズとも Pelle Frau® ベッレ・フラウ® SC のレザー張りのタイプ、もしくは、Noce Canaletto カナレット・ウォールナットにレザーの縁取りを施したタイプがある。写真の製品のレザーの色は SC 57 Torba 泥炭色。オープン・コンパートメントの仕切りはクリア・ガラス製で、旋盤で成形したスチールの支柱に合わせてカーブがついている。扉つきのコンパートメントには鍵で閉める錠がついている。

两种尺寸，285 cm 与 194 cm，任何一种款式都可以选择包裹从色彩系统中精选出的 Pelle Frau® 皮革套面，或采用 Canaletto 胡桃木贴皮交织细条皮革编织带。图式款为 SC 57 Torba 皮革。为了与不锈钢质地的支撑住相呼应，开放式储物单元之间的夹层采用透明玻璃材质。带柜门的储物单元均配备锁与钥匙。



Corinthia Easy Desk with 3 drawers — Pelle Frau® SC leather / Canaletto walnut

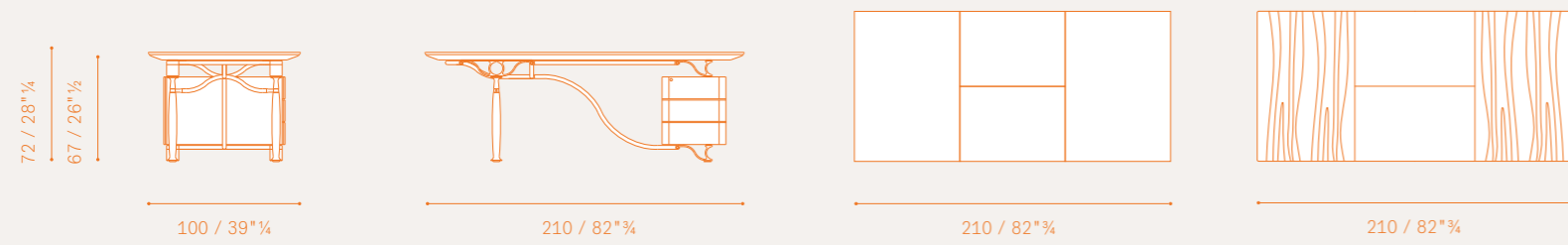

Corinthia Easy Desk with 3 drawers — Pelle Frau® SC leather / Canaletto walnut

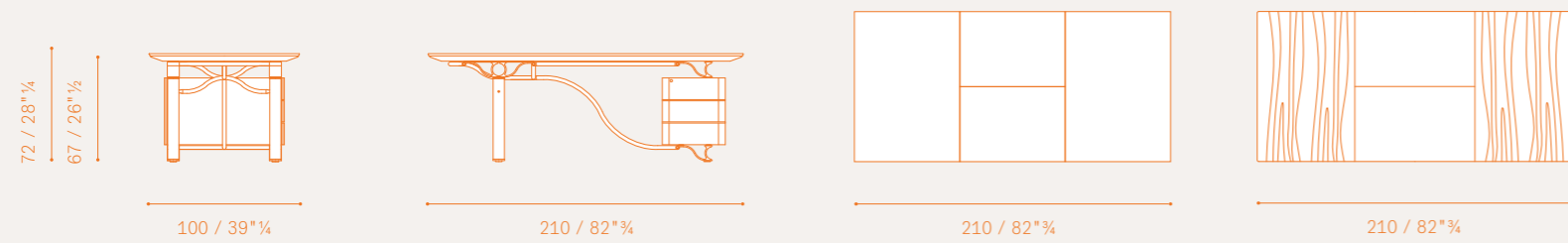

Corinthia Easy Desk — Pelle Frau® SC leather / Canaletto walnut

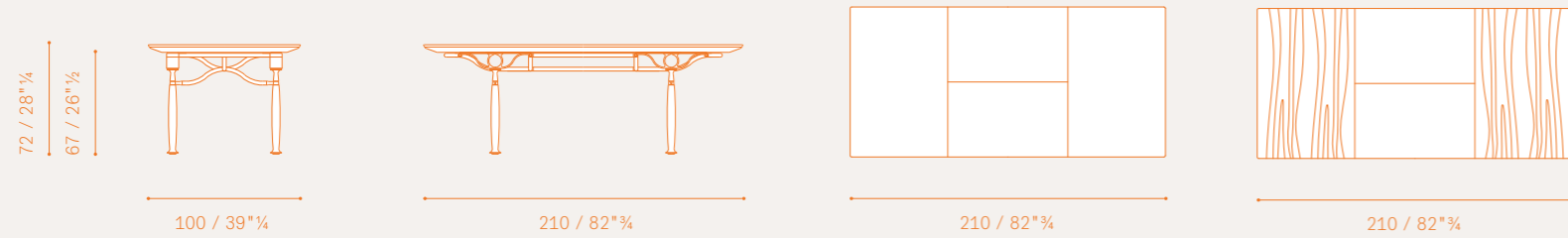

Corinthia Easy Desk — Pelle Frau® SC leather / Canaletto walnut

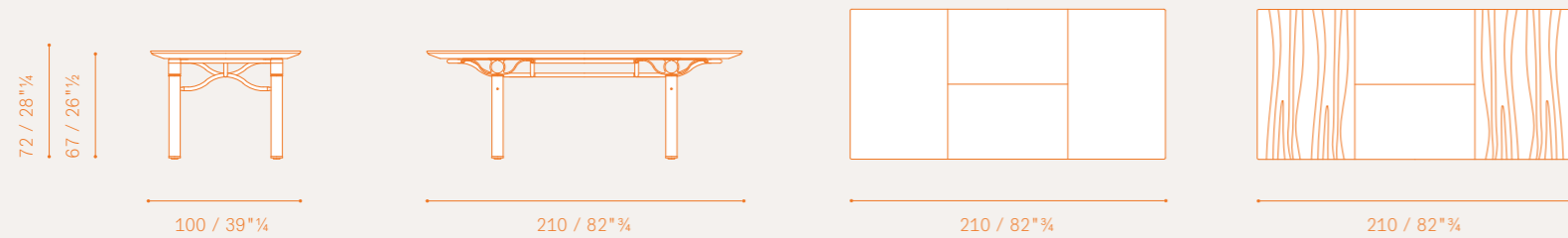

Corinthia Low Cabinet 285cm — Pelle Frau® SC leather

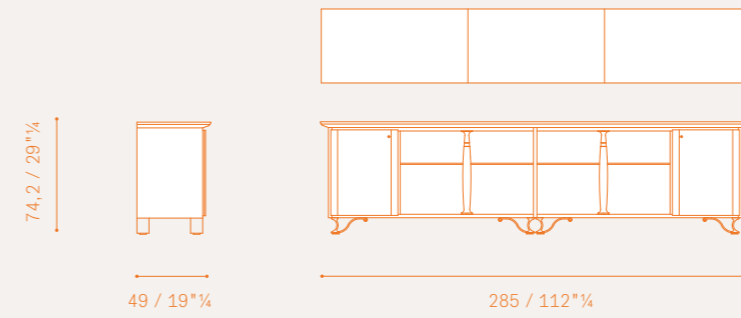

Corinthia Low Cabinet 285cm — Pelle Frau® SC leather / Canaletto walnut

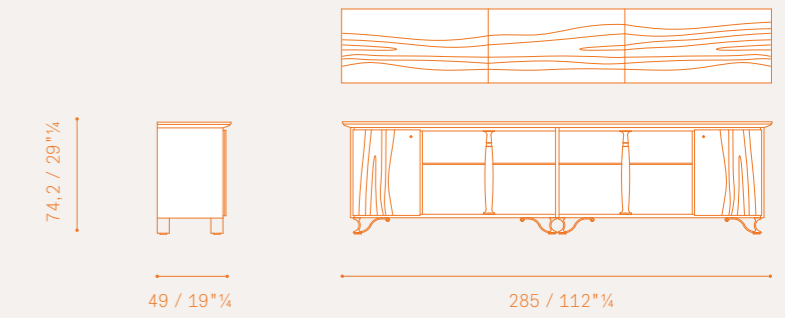

Corinthia Low Cabinet 194cm — Pelle Frau® SC leather

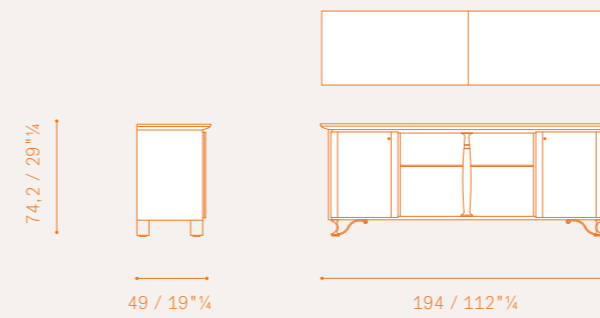

Corinthia Low Cabinet 194cm — Pelle Frau® SC leather / Canaletto walnut

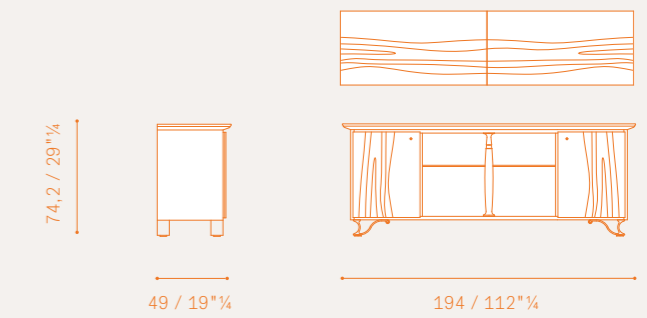

Corinthia Drawers unit 2 / 3 drawers — Pelle Frau® SC leather

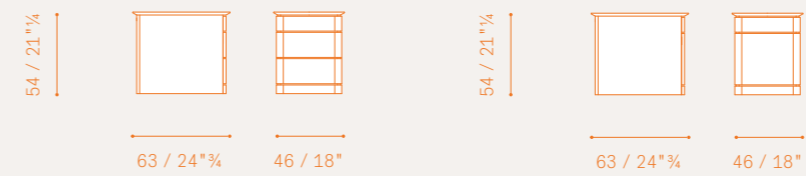

Corinthia Round Table — Pelle Frau® SC leather

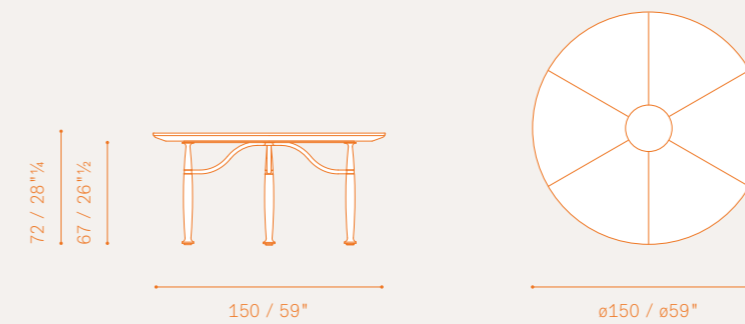

Corinthia Round Table — Pelle Frau® SC leather / Canaletto walnut

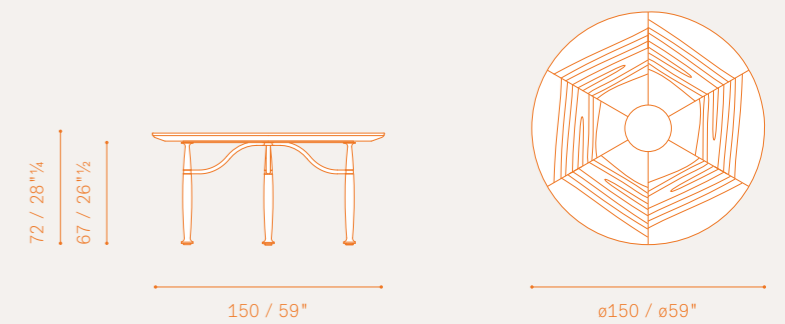

Corinthia Meeting Table 280x150cm / 350x150cm — Pelle Frau® SC leather / Canaletto walnut

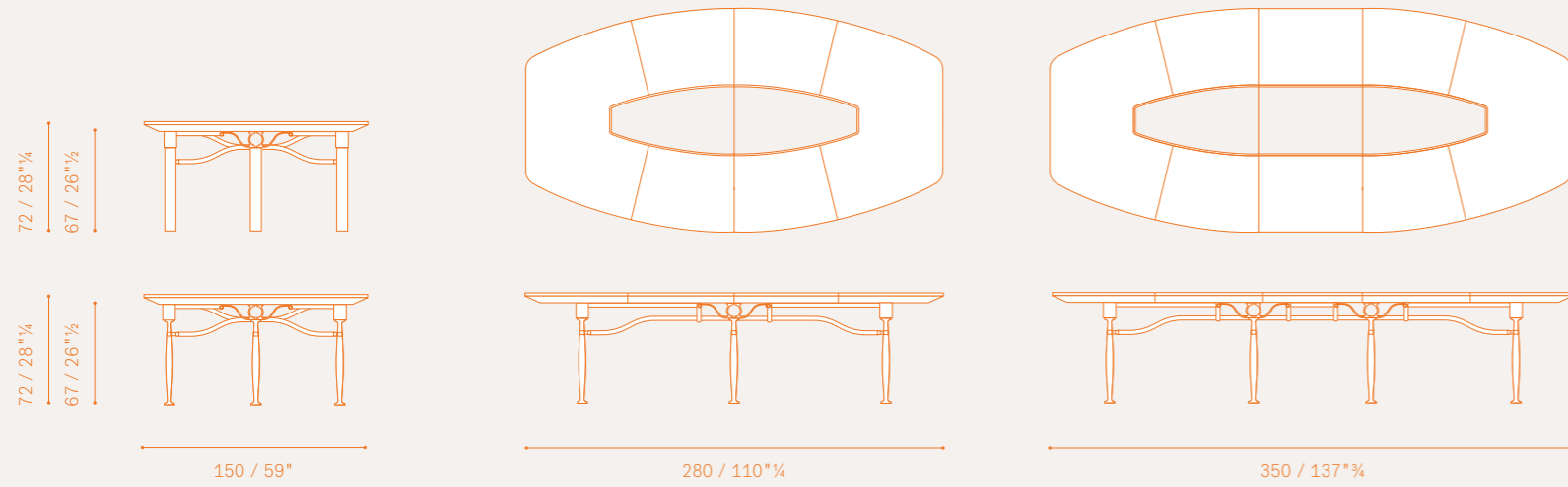

Corinthia Meeting Table 560x150cm — Pelle Frau® SC leather / Canaletto walnut

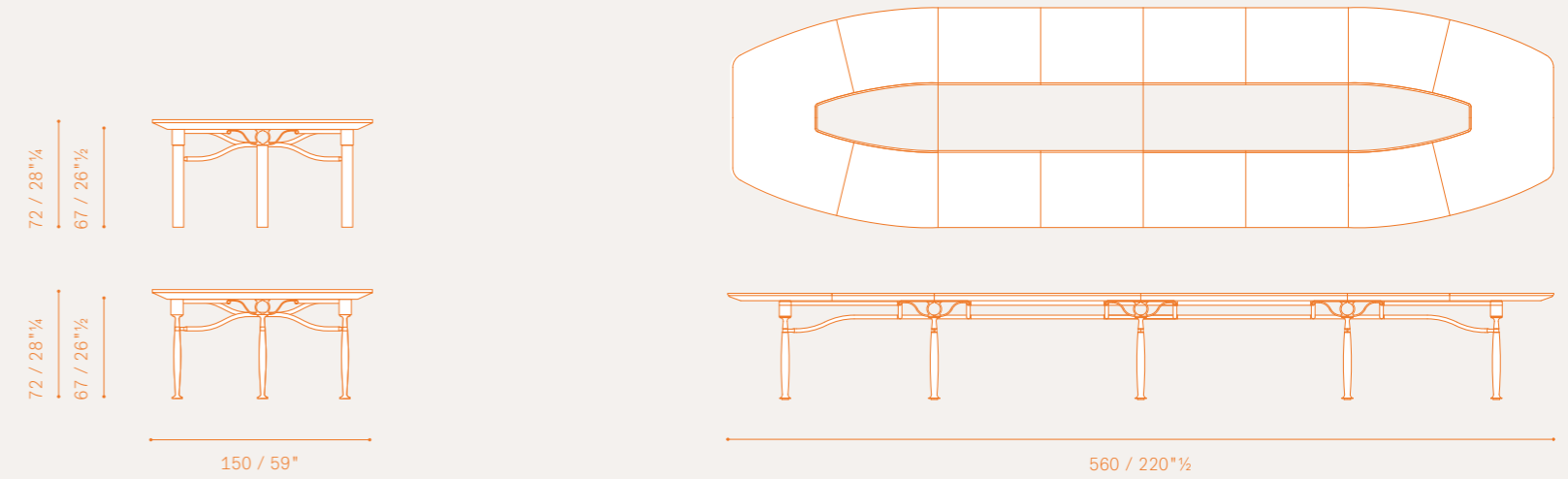

Corinthia Meeting Table 420x150cm — Pelle Frau® SC leather / Canaletto walnut

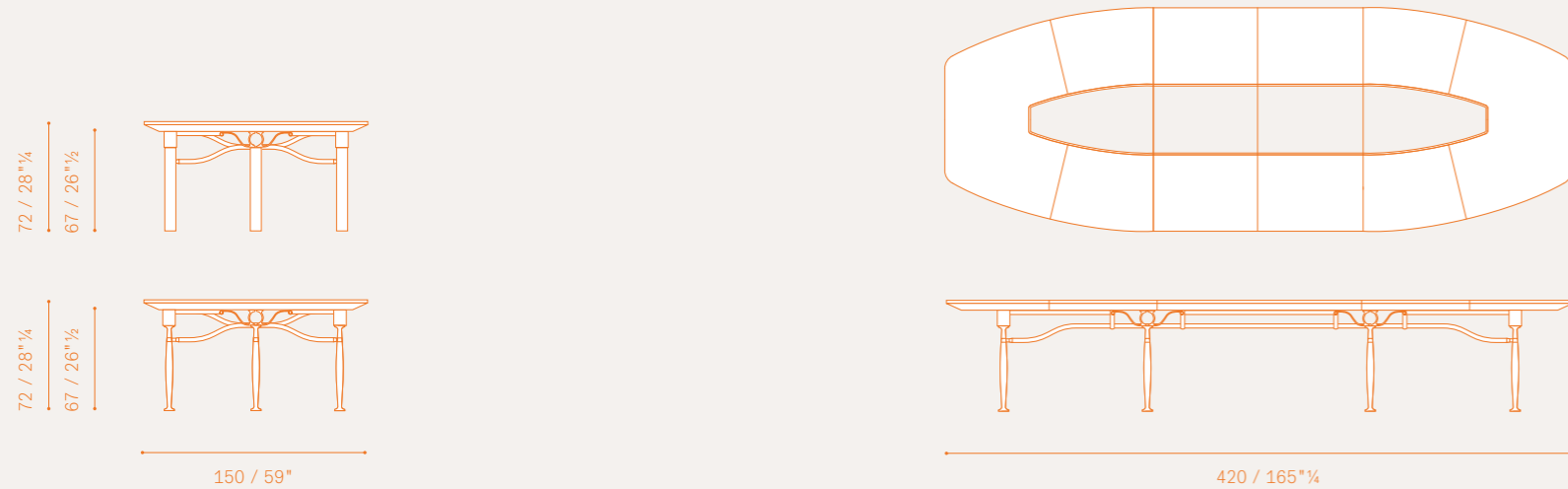

Corinthia Meeting Table 630x150cm — Pelle Frau® SC leather / Canaletto walnut

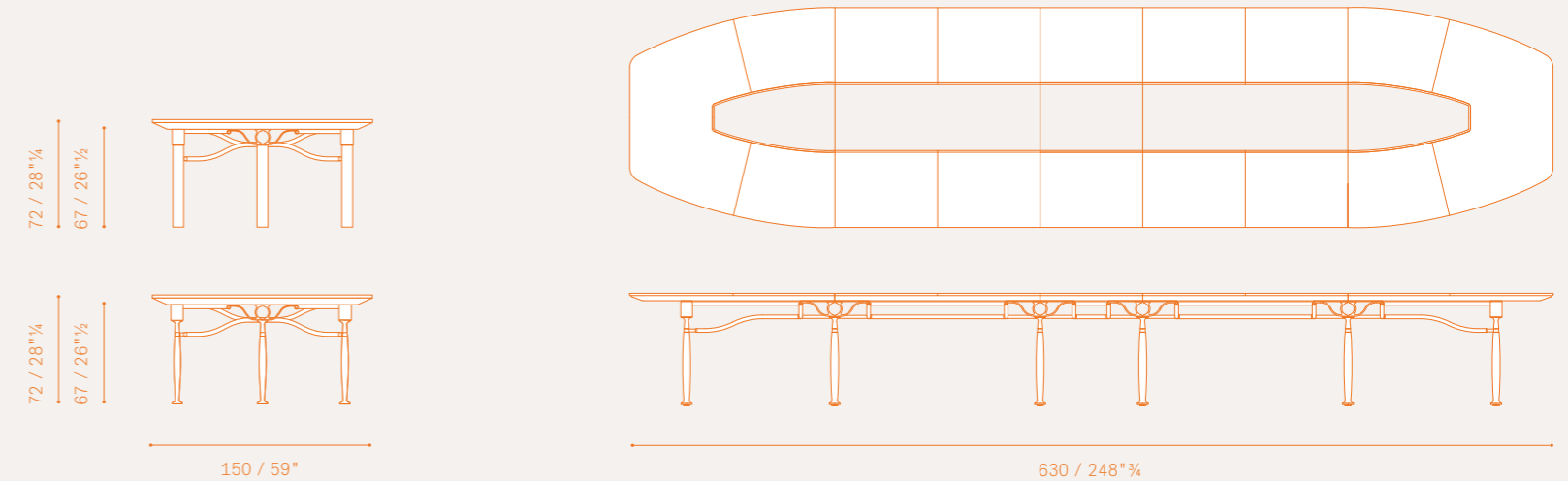

Corinthia Meeting Table 490x150cm — Pelle Frau® SC leather / Canaletto walnut

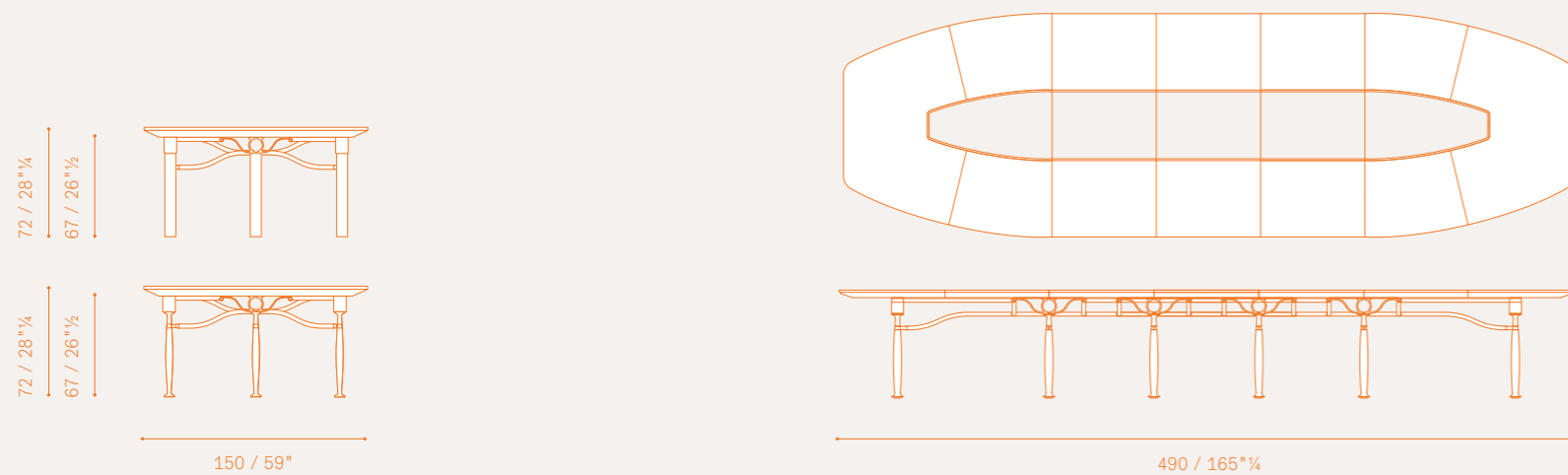

Corinthia Meeting Table 700x150cm — Pelle Frau® SC leather / Canaletto walnut

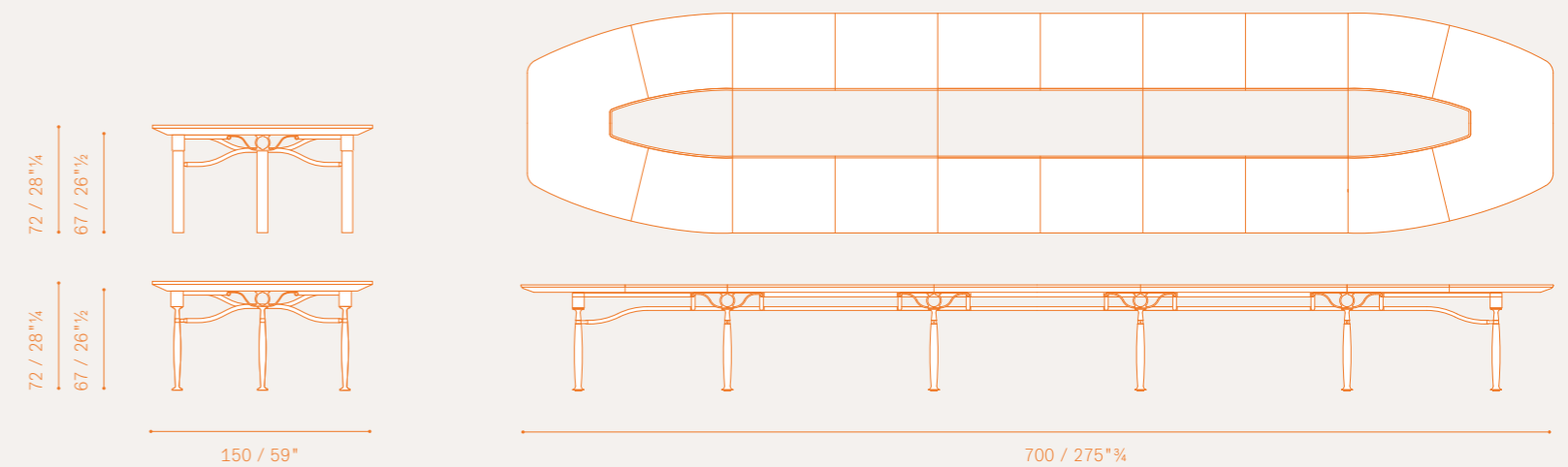

Jean-Marie Massaud

DownTown



JEAN-MARIE MASSAUD

Laureato all'ENSCI nel 1990, Jean-Marie Massaud è fin da subito alla ricerca di sintesi, riduzione e leggerezza. Affronta i diversi aspetti del design: dai mobili ai prodotti industriali, alle attrezzature. Nel 2000, crea lo Studio Massaud ed estende la sua attività all'architettura e alle strategie di sviluppo. Ponendo l'uomo ed il suo ambiente naturale al cuore delle sue creazioni, questo ideatore senza limiti adotta un modo di procedere impegnato e politico e si sforza di trasformare ogni progetto in un'esperienza di vita e in uno scenario economico che riconcilia desiderio e responsabilità.

CONCEPT

Competente, elegante, senza tempo. Downtown è la poltrona da lavoro dedicata a "decision-makers" esigenti che ricercano comfort e eleganza raffinata. Una seduta tecnica che si rivela una silhouette, fatta a mano dagli artigiani di Poltrona Frau come garanzia di alta qualità. Molto più di una bella scultura, Downtown è una creazione sensuale e distintiva di Jean-Marie Massaud.

Poltrone Ufficio — DownTown

JEAN-MARIE MASSAUD

Jean-Marie Massaud graduated from ENSCI (the French national school for advanced studies in design) in 1990 and from the very outset he has sought synthesis, essentiality and lightness. He has handled all aspects of design, from furniture to industrial products and equipment. In 2000, he founded Studio Massaud and expanded his expertise to architecture and brand development. By placing humanity and the natural environment at the heart of his creations, this free-thinking designer adopts an engaged and political approach, striving to make every project into a life experience and to do so within an economic framework that reconciles desire and responsibility.

CONCEPT

Proficient, elegant, and timeless. DownTown is a desk armchair specially dedicated to demanding decision-makers who seek comfort and refined elegance. A technical seat that looks like a silhouette; handcrafted by Poltrona Frau as a guarantee of the highest quality. More than a beautiful sculpture, DownTown is a sensual and distinctive creation by Jean-Marie Massaud.

Office Armchairs — DownTown

ジャン・マリー・マッソー

1990年にENSCIを卒業してすぐに、Jean-Marie Massaudは、合成と縮小そして軽さの研究を始め、家具から工業製品や機材におけるまで、デザインの(多様な側面)多面性の考察を行う。2000年には、Studio Massaud (マッソー・スタジオ)を設立し、建築や開発計画にまで活動の拡大。創造の中心に人間と自然環境というテーマを想定し、その限界を持たない考案者は積極的かつ政治的な工程を進める方法を選びつつ、あらゆるプロジェクトを人生の経験として、また欲望と責任感を折衷する経済的なシナリオとして、形を変える努力をしている。

コンセプト

卓越していて、優雅で、時間効果なしには。DownTownは、快適性と洗練された優雅さを求める、要求の多い"decision-makers" デシジョンメーカーのために仕事用アームチェアです。技術的に座ってもまるでシルエットの様で、職人の手作業手作りから生まれる Poltrona Frau (ポルトローナ・フラウ)の品質の高さを証明しています。DownTownは、美しい彫刻以上のもの、Jean-Marie Massaudによる官能的で比類のない被造創造的物なのです。

オフィス用アームチェア — DownTown

让·马利·马沙德

让·马利·马沙德 1990年毕业于 ENSCI (法国高级设计学校) 后, 立即致力于综合化、精简化和轻巧化的研究之中。他的设计涉及各个领域: 从家具到工业产品, 再到设备。2000年创建了马沙德事务所并拓展了其建筑及品牌拓展的业务。以人和自然环境为创意的核心, 设计师采取合理的方式将每个项目转变为人生的体验, 并在理想的框架下调和需求和责任。

理念

干练、优雅、经久耐用。DownTown 是专为寻求舒适、典雅、细腻的决策者而设计的办公椅。专业的办公椅看起来像一件艺术品, 由 Poltrona Frau 的工匠手工制作, 是高品质的保证。但又不仅仅作为一个艺术品 DownTown 也是让·马利·马沙德 Jean-Marie Massaud 的一个情感上的独特创造。

领导体系 — DownTown



Regolabili in altezza e rotabili su stesse, le versioni President, Executive e Managerial sono dotate di un meccanismo di oscillazione "Sincron" di schienale e sedile che permette alla poltrona di seguire con estrema facilità l'andamento del corpo, con possibilità di blocco in 4 posizioni. La versione Meeting può ruotare su se stessa mentre la Visitor è dotata di un meccanismo di rotazione con ritorno nella posizione di partenza.

The President, Executive and Managerial versions are height adjustable and can rotate. The "Sincron" turning mechanism for the seat and backrest allows the armchair to easily accompany the body's movements and allows it to be locked into 4 different positions. Downtown Meeting can rotate around its axis. Downtown Visitor is fitted with an automatic return rotation mechanism.

高さ調節可能で、回転式。President、Executive、Managerial のモデルは背部と座部の角度を4段階に調節できる "Sincron" シンクロンというリクライニング装置付きで、掛け心地は快適。Meeting モデルは回転式、Visitorモデルはオートリターン機能付。

总裁椅、行政椅以及经理椅的款型均可以调节座高，并且可以旋转。“同步”旋转机械装置可以使单椅的座位以及靠背轻松配合人体的运动，并且可以在4个不同位置上进行锁定。Downtown 会议系列办公扶手椅围绕自身轴线原地转动。Downtown 访客椅配备了自动回转的装置。





Il rivestimento, impreziosito con cuciture tono su tono o a contrasto, è in Pelle Frau® del Color System disponibile anche nella versione con microforatura sulla superficie interna della seduta di schienale, braccioli e cuscino. La base d'appoggio, in alluminio lucido o verniciato nero, è composta da 5 razze attrezzate con ruote tipo "W" piroettanti autofrenanti morbide o scivoli. La versione Visitor ha un basamento a 4 razze con scivoli girevoli.

The upholstery, embellished with tone-on-tone or contrast stitching, is made with Pelle Frau® SC leather, and is also available in a version with micro-perforations on the inner surface of the backrest, armrests and cushion. The five-spoke resting base, available in either polished aluminium or with a black finish, is fitted with soft, self-blocking "W" type wheels or swivel glides. The Visitor version has a 4-spoke base with swivel glides.

革張りには Pelle Frau® Color System カラーシステムのペッレ・フラウ®を使い、トーン・オン・トーン又はコントラスト・カラーのステッチで高級感を際立たせる。座部、背部、肘掛、クッションの身体に接する側の面に微小なバンチングが施された革張りもある。光沢仕上げ又はブラック塗装仕上げのアルミ製支柱から脚が5本、車輪表面がソフトタイプのオートブレーキ機能付 "W" 型回転式キャスター付、又はグライダー・キャスター付。Visitor モデルは支柱から脚が4本、回転式グライダー・キャスター付。

软包的套面装饰有褶边多色调车线或对比车线，并从 Color System 色彩系统中精选的 Pelle Frau® 皮革，还可以选择在靠背、扶手以及靠垫的内侧套面开小透气孔的款式。五轮底座支架可选择抛光或黑色饰面铝金属，并配备柔软的可锁定 "W" 型脚轮或万向轮。访客椅的底座为四轮支架，并配备万向轮。

DownTown President / Executive / Managerial / Meeting / Visitor



DownTown President — Castors or glides

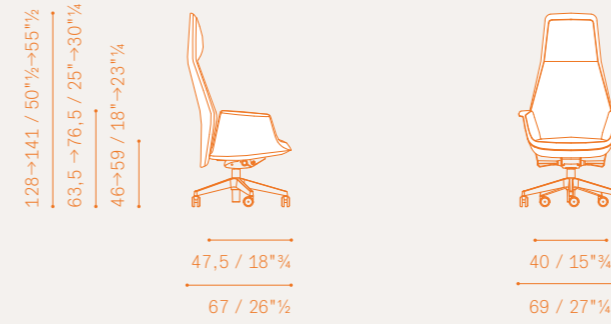

DownTown Executive — Castors or glides

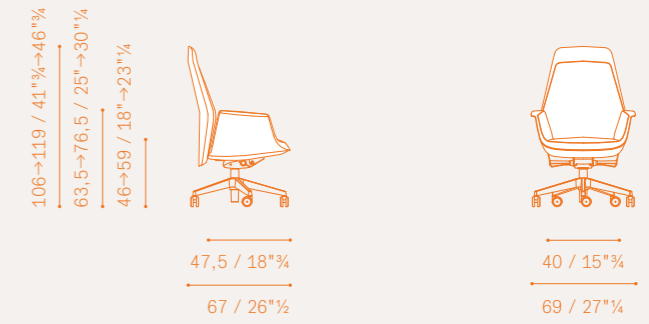

DownTown Managerial — Castors or glides

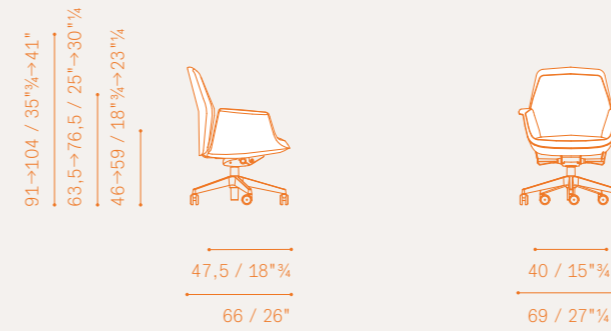

DownTown Meeting — Castors or glides

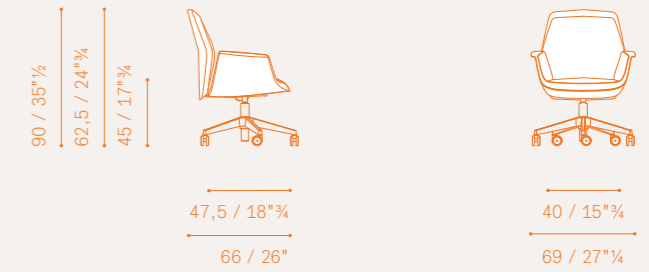

DownTown — Finishings

- Upholstery**
- Pelle Frau® leather from the Color System
 - Micro-perforated Pelle Frau® leather from the Color System

- Base**
- Aluminium in a black finish
 - Polished aluminium

DownTown Visitor — Glides

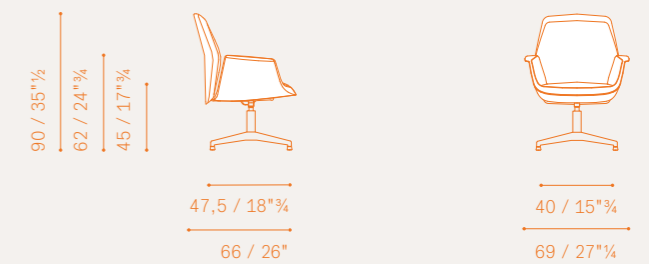

Roberto Lazzeroni

Ginger Ale



ROBERTO LAZZERONI

Nato a Pisa, Roberto Lazzeroni compie un percorso professionale dinamico legato agli studi di Arte e Architettura compiuti a Firenze e agli interessi maturati, negli anni della sua formazione, verso i fenomeni dell'arte concettuale e del Radical Design. Debutta all'inizio degli anni '80 con una serie di importanti lavori di "Architettura d'Interni", subito notati e pubblicati da riviste italiane ed estere. Impegnato su diversi fronti con collaborazioni prestigiose, art direction e progetti d'interni e contract in varie parti del mondo, annovera importanti riconoscimenti internazionali.

CONCEPT

Ginger Ale Office riprende l'iconica scocca a guscio con le due aperture laterali a goccia tipiche di Ginger e Ginger Ale, ampliandone ulteriormente le possibilità d'uso. Fresca, ben disegnata, modernissima nelle sue varianti, si presta con versatilità sia agli spazi di lavoro, come seduta per singole postazioni o sale riunioni, che agli spazi pubblici o alla zona studio/lavoro di casa.

Poltrone Ufficio — Ginger Ale

ROBERTO LAZZERONI

Pisa-born Roberto Lazzeroni has enjoyed a dynamic career path very much linked to his art and architecture studies in Florence and the interest he acquired, while studying, in the phenomena of conceptual art and Radical Design. He made his debut in the early 1980s with a series of important "Interior Design" works, which were immediately noticed and published by national and international magazines. He has been engaged on several fronts with prestigious collaborations, art direction and interior design and contract projects in various parts of the world, and has won major international awards.

CONCEPT

Ginger Ale Office takes the iconic shell with the two lateral drop-shaped openings typical of Ginger and Ginger Ale and further expands their possible use. Fresh, well-designed, and highly modern with a number of variants, it lends versatility to work spaces, as a seat for individual workstations or meeting rooms, and to public spaces or study and work areas in the home.

Office Armchairs — Ginger Ale

生命伝記

ピサ生まれ。Roberto Lazzeroni (ロベルト・ラッツオーニ)は、フィレンツェで勉強した美術・建築と彼が長年興味を持っていたコンセプチュアル・アートと Radical Design (ラディカル・デザイン)の現象を結び付けながら、精力的に仕事を積み重ねてきました。80年代初頭に、一連の "Architettura d'Interni" (インテリア建築)の重要な作品でデビューし、即座に注目されたイタリア内外の雑誌に掲載

され話題になりました。また、一流の世界でのコラボレーションやアートディレクション、内装設計や世界各国からのコントラクトなど多分にで積極的に活動を行い、世界的に高い知名度を得ています。

コンセプト

Ginger Ale Office (ジンジャー・エール・オフィス)では、ジンジャーとジンジャー・エールの特徴である一滴のしずくの形をした二つの穴を両脇に空けたシェルがその椅子の本領になっていますが、このデザインがさらに使い勝手の幅を広げています。新鮮で、良質なデザイン、バラエティーに富んでいて現代的なこのアームチェアは、個人使用、または会議など仕事の場、かつ公共の場所や勉強・家事のスペースにも合うなど大変多才です。

オフィス用アームチェア — Ginger Ale

罗伯特·拉泽罗尼

出生于比萨，在佛罗伦萨出色地完成了建筑学及艺术学的专业学习，在学习的那几年里，获得了浓厚的概念艺术和激进设计现象的兴趣。自八十年代初的一系列重要的“室内设计”作品而初露头角，之后立即引起了意大利及国外杂志的注意并公开发表其作品。其在世界各地均有签约并从事于室内项目、艺术指导、高端合作等前沿工作，从而在国际上被熟知。

理念

Ginger Ale 办公椅采用并延展了 Ginger 和 Ginger Ale 座椅的合理使用，侧面水滴形开口的标志性外型依然是其特点。清新、巧妙设计、多变并极富现代感，用途广泛，可以是独立的工作区，也可以出现在会议室，满足公共空间或家庭学习工作区域的多功能性。

领导体系 — Ginger Ale



La scocca esterna è realizzata in polimero termoplastico composito ottenuto da stampo, disponibile nei colori "antracite", "cemento" o "gesso". Ginger Ale è disponibile con 4 varianti di base, nelle finiture verniciata, "antracite", "cemento" o "gesso" in abbinamento alla scocca, o cromata. Rivestimento in Pelle Frau Color System®

The outer shell is made of moulded thermoplastic composite polymer, and is available in the colours "anthracite", "cement" or "chalk". Ginger Ale is available in 4 versions with an "anthracite", "cement" or "chalk" varnish matching the shell, or chromium plated. Pelle Frau® leather from the Color System upholstery

ボディーは熱可塑性ポリマーの金型成形。"チャコールグレー"、"セメント"あるいは"チョコレート"のカラーが選べる。Ginger Ale の支柱には4つの基本色が用意されており、ボディーとのコーディネートで"チャコールグレー"、"セメント"、"チョコレート"の塗装仕上げ、そしてクロム仕上げがある。革張りは Pelle Frau® Color System ベッレ・フラウ®カラー・システム

这款办公椅的外壳由高分子聚合物热塑成型，有“炭黑色”与“粉白色”两款可供选择。填充物为聚氨酯海绵，座位的内表面包裹从色彩系统中精心挑选的 Pelle Frau® 皮革。Ginger Ale 办公椅有3款底座，“炭黑色”或“粉白色”的清水漆或镀铬表面。





La base a 5 razze con ruote è realizzata in acciaio e disponibile sia nella versione girevole ad altezza fissa sia nella versione con molla a gas per la regolazione dell'altezza seduta. È dotata di ruote piroettanti auto-frenanti morbide con supporto in plastica nera per le versioni verniciate e supporto in zama pressofusa con finitura cromata per la versione cromata.

The 5-spoke base with wheels is made in steel and is available in a fixed-height swivel version and also in a gas spring version so you can adjust the seat height. Equipped with soft, self-blocking swivel wheels with a black plastic support for the varnished versions and a die-cast zamak support with a chrome finish for the chromium-plated version.

回転式で高さが固定されたモデルとガス・シリンダーで座部の高さを調節できるモデルがある。スチール製支柱から脚が5本、セルフ・ブレーキ機能付回転式で車輪の表面がソフト・タイプのキャスター。塗装仕上げではサポート部分はブラックの合成樹脂製、クロム仕上げではサポート部分はプレス製造した亜鉛合金にクロム仕上げ。

5 轮底座选用金属钢材质,可以选择固定高度的转椅款式或可以调节坐高的气压款式。旋转脚轮柔软、并自带锁扣功能(W 型脚轮可以适用于任何种类的地面),清水漆的款式为黑色塑料支撑连接件,镀铬款式采用表面镀铬的压铸锌合金作为支撑连接。

Poltrona con base a 5 razze con ruote
(altezza fissa o regolabile)

Armchair with 5-spoke base
(fixed or adjustment height)

5スポーク・ベース付きアームチェア
(高さ固定もしくは可動式)

5 星滚轮单椅 (固定高度或高度可调)



Poltrona con base a 4 razze

Armchair with 4-spoke column base
(fixed or swivel)

4 スポーク・コントラクト・ベース付きアームチェア (固定もしくは回転式)

4 腿扶椅 (固定或可旋转)



Poltrona con colonna a 4 razze
(fissa o girevole)

Armchair with 4-spoke base

4 スポーク・ベース付きアームチェア

4 星轮辐单椅



Poltrona con base metallica
e gambe coniche

Armchair with conical metal supports

金属製円錐形脚部付アームチェア

椅脚为锥形的金属支脚

Ginger Ale — Armchair with 5-spoke base and fixed-height

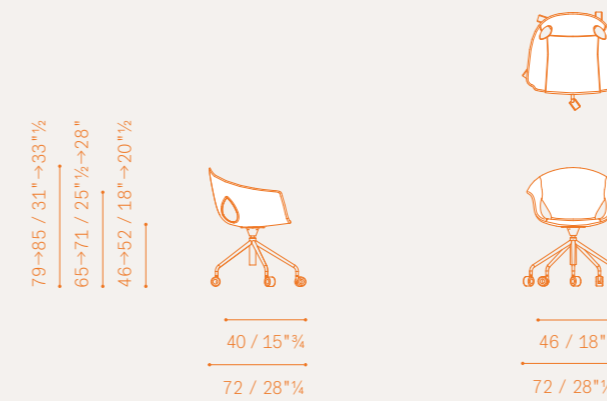

Ginger Ale — Armchair with 5-spoke base and height-adjustment

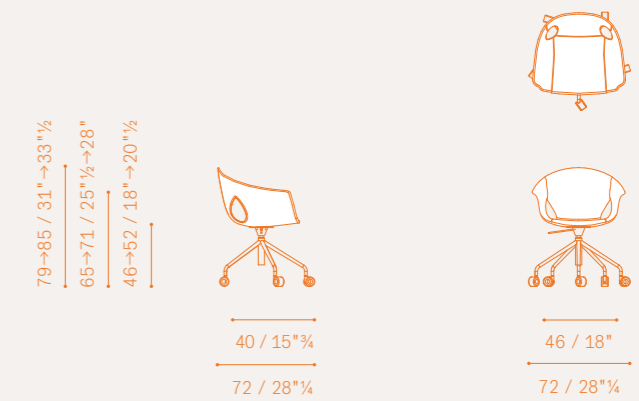

Ginger Ale — Fixed or Swivel armchair with 4-spoke column base

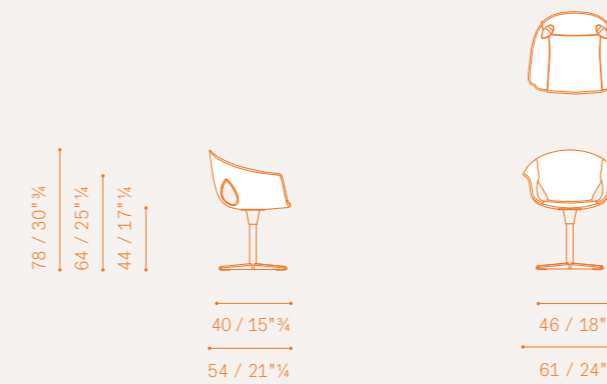

Ginger Ale — Armchair with 4-spoke base

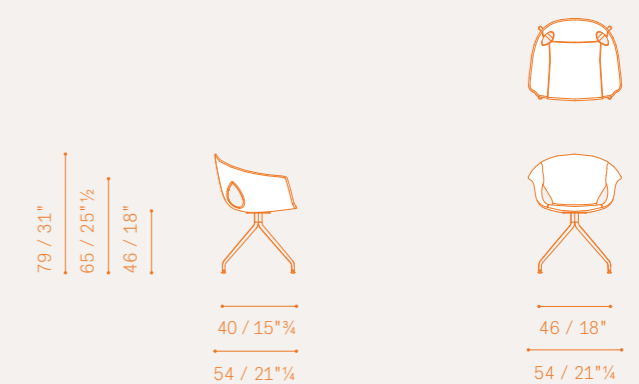

Ginger Ale — Finishings

Upholstery

— Pelle Frau® leather from the Color System

External frame finish

— "Chalk" color
— "Anthracite" color
— "Cement" color

Base finish

— "Chalk" color
— "Anthracite" color
— Chrome finished metal
— "Cement" color

Ginger Ale — Armchair with conical metal supports

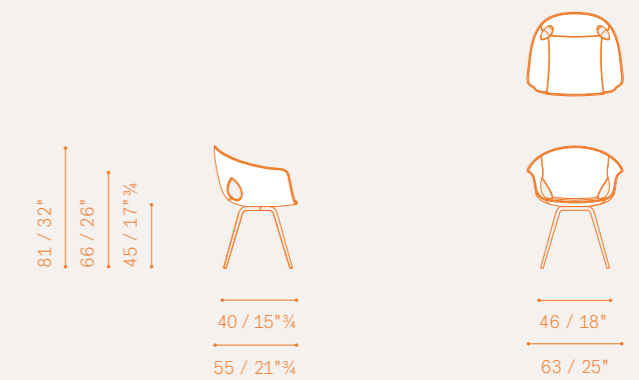

Chancellor



LIEVORE - ALTHERR - MOLINA

Lo studio Lievore Altherr Molina nasce nel 1991 dalla fusione di tre partner: Alberto Lievore, Jeannette Altherr e Manel Molina. Sin dalla sua fondazione si è dedicato al design di prodotto, alla consulenza e alla direzione artistica di varie aziende. Nel corso degli anni lo studio ha avuto numerosi riconoscimenti nazionali e internazionali, tra cui Design Award nazionale spagnolo nel 1999, e ha sviluppato, contemporaneamente, notevoli capacità di insegnamento realizzando seminari e corsi di formazione per nuove figure professionali in diverse università spagnole e altre organizzazioni.

CONCEPT

L'essenzialità formale di un confortevole abbraccio. Una collezione di sedute dalle sobrie geometrie ed una forte presenza scenica nello spazio di lavoro. I braccioli continui con il piano seduta suggeriscono nuove gestualità e sono concepiti per migliorare il livello di comfort e relax.

LIEVORE - ALTHERR - MOLINA

Lievore Altherr Molina was created in 1991 by the merging of its three partners: Alberto Lievore, Jeannette Altherr and Manel Molina. Since its founding, the studio has been devoted to product design, consulting and the art direction of various companies. Throughout the years the studio has been awarded many national and international awards, including Spain's National Design Award in 1999. Simultaneously, it has developed an intense teaching practice, giving seminars and training courses to new professionals at various Spanish universities and other organizations.

CONCEPT

The formal purity of a comfortable embrace. A collection of sober, geometrical chairs with a strong scenic presence in the workplace. The arms that continue on from the seat provide a new expression and are designed to improve comfort levels and enhance relaxation time.

リエヴォレ - アルテール - モリーナ

Lievore Altherr Molina リエヴォレ - アルテール - モリーナ・スタジオは 1991 年にアルベルト・リエヴォレ、ジャネット・アルテール、マネル・モリーナ、3 名の合同で創設された。当初から、プロダクト・デザイン、様々な企業のコンサルティングやアーティスティック・ダイレクションを手掛けた。以来、同スタジオは 1999 年のスペイン・ナショナル・デザイン・アワードをはじめ、国内外の数多くの賞を受賞して来た。同時に、スペインの大学やその他の団体で新進のプロを育成するセミナーや養成講座を通して、優れた指導力も発揮している。

コンセプト

快適な掛け心地を生み出す無駄の無いフォルム。すっきりとしたデザインが職場で存在感を発揮するアームチェアのコレクション。座部から続く肘掛により、新しい座り方が暗示され、コンフォート感やリラックス感がいっそう高まる。

LIEVORE - ALTHERR - MOLINA

Lievore Altherr Molina 创作于 1991 年，是根据三位合作伙伴的名字命名，他们分别是 Alberto Lievore, Jeannette Altherr 和 Manel Molina。成立以来，这家事务所便专注于产品设计，并为众多公司进行艺术指导及顾问工作。经年累月，这家事务所囊括了包括 1999 年西班牙国家设计奖在内的许多国内国外的大奖。与此同时，他们还开发了一套有针对性的教学内容，为西班牙大学或专业机构的新晋专业从业者提供讲座和培训课程。

理念

这是一个纯正的舒适怀抱。一把造型朴素，几何感极强的单椅，放置在工作区域有很强大的气场。扶手的造型是由座位延伸而来，提供了一种全新的设计表达方式，将舒适感提升到新的境界，提高休闲时间的质量。



La base d'appoggio, disponibile in alluminio verniciato grigio scuro o in alluminio lucido, è composta da 5 razze attrezzate con ruote tipo "W" autofrenanti morbide o scivoli girevoli. La versione Visitor ha una base d'appoggio a 4 razze sempre fornita con scivoli girevoli.

In the President, Executive, Managerial and Meeting versions, the five-spoke resting base, which is available either in polished aluminium or a dark grey finish, is fitted with soft, self-braking "W" type wheels or with swivel castors. The Visitor version has a 4-spoke base with swivel glides.

座部を支える支柱はダークグレー塗装仕上げ又は光沢仕上げのアルミ製、支柱から脚が5本、車輪の表面がソフト・タイプのセルフ・ブレーキ機能付"W"型キャスター、又は回転式グライダー・キャスター付。Visitorモデルは支柱から脚が4本、回転式グライダー・キャスター付。

在总裁椅、行政椅、经理椅及会议椅款型中，五轮底座支架可选择抛光或深灰色饰面铝金属，并配备柔软的可锁定"W"型脚轮或万向轮。访客椅的底座为四轮支架，并配备万向轮。





Regolabili in altezza e rotabili su stesse, le versioni President, Executive e Managerial sono dotate di un meccanismo di oscillazione "Sincron" di schienale e sedile che può assumere una serie continua di 5 posizioni fino a diventare una vera e propria chaise-longue. Il rivestimento in Pelle Frau® del Color System può essere esteso anche al carter di copertura del movimento "Sincron". La versione Meeting può ruotare su se stessa mentre la Visitor è dotata di un meccanismo di rotazione con ritorno nella posizione di partenza.

The President, Executive and Managerial versions are height adjustable, rotate, and are fitted with a "Sincron" turning mechanism for seat and backrest, that boasts a continual series of 5 different positions ranging into an actual chaise-longue. Upholstery is in Pelle Frau® leather from the Color System. A thrust-bearing mechanism allows Meeting to rotate around its axis. Chancellor Visitor is fitted with an automatic return rotation mechanism.

高さ調節可能で回転式。President, Executive、Managerial のモデルには、背部と座部に "Sincron" シンクロンという段階式のリクライニング装置が付いており、シェーズ・ロングさながらの角度まで傾ける事ができる。Pelle Frau® del Color System カラーシ・ステムのペッレ・フラウ®の革張りで "Sincron" シンクロン装置のクランクケースのカバーまで覆う事も可能。Meeting モデルは回転式、Visitor モデルはオートリターン機能付。

总裁椅、行政椅以及经理椅的款型均可以调节座高，并且可以旋转。“同步”旋转机械装置可以使单椅的座位以及靠背轻松配合人体的运动，并可以连续5档调节位置，直至变成一张真正的长榻。套面软包为从 Color System 色彩系统中精选的 Pelle Frau® 皮革，同时也可以包裹“同步”旋转机械装置的金属件。由于安装了推力轴承机械装置，使得该款办公扶手椅可以围绕自身轴线原地转动。Chancellor 访客椅配备了自动回转的装置。

Chancellor President / Executive / Managerial / Meeting / Visitor



Chancellor President

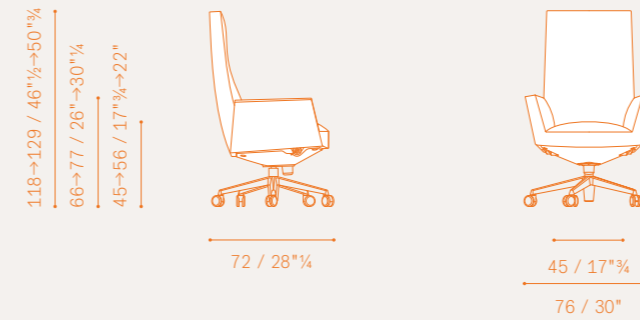

Chancellor Executive

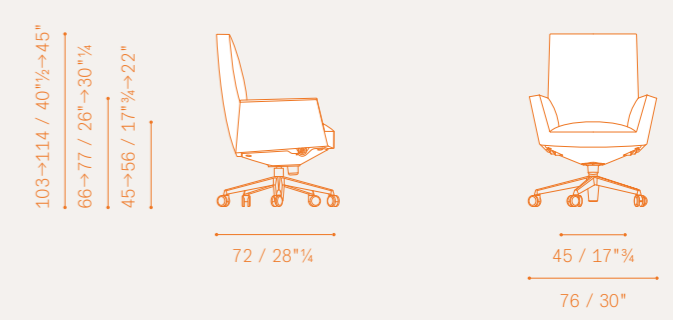

Chancellor Managerial

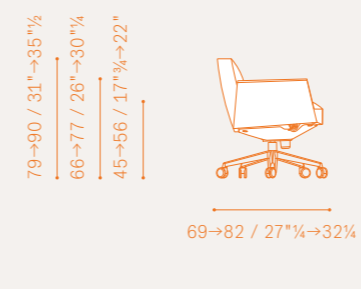

Chancellor Meeting

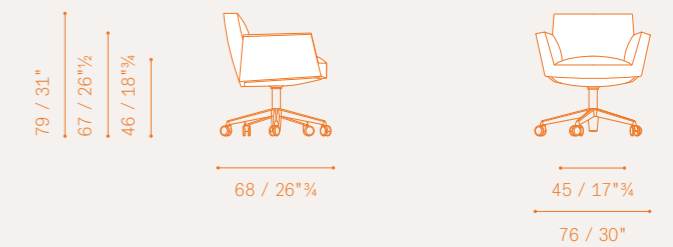

Chancellor — Finishings

Upholstery

— Pelle Frau® leather from the Color System

Base

— Aluminium in a dark grey finish
— Polished aluminium

Stitching

— in matching tones thread
— with a contrast thread

Supports

— Soft, self-braking "W" type castors
— Swivel glides (2 cm lower height)

Chancellor Visitor

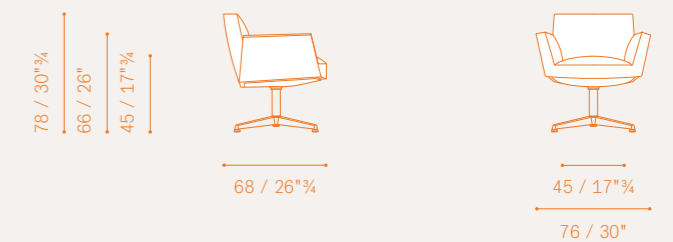

Poltrona Frau R. & D.

Forum



POLTRONA FRAU R. & D.

Dalla seconda metà degli anni sessanta Poltrona Frau ha creato una struttura interna che si occupa di ricerca e sviluppo. Ogni giorno, accanto alla salvaguardia del know-how di alta artigianalità, il Centro Ricerche e Sviluppo sperimenta nuovi materiali, nuove tecniche costruttive e realizza nuove forme. Il gruppo, che è formato da tecnici altamente specializzati nella progettazione, può contare su di un attrezzatissimo reparto di prototipazione nel quale dare forma alle nuove idee. Molto efficace, per la messa a punto di prodotti eccellenti nella qualità e conformi alle normative internazionali, è il Laboratorio di Analisi e Sperimentazione nel quale vengono testati i prodotti e le materie prime.

CONCEPT

Una ricca collezione di sedute per l'ufficio direzionale e di medio livello che riprende le forme classiche e i dettagli propri della tradizione artigiana Poltrona Frau, come il ricciolo a voluta dello schienale e del sedile.

POLTRONA FRAU R. & D.

Poltrona Frau, Second half of the 60. In the second half of the 1960s, Poltrona Frau created an internal structure to manage research and development. Whilst preserving the know-how of expert craftsmanship, the Centre for Research and Development experiments with new material, new building techniques and creates new forms. The highly specialised design technicians that make up the group benefit from a superbly equipped prototype laboratory, where they can give form to new ideas. Products and raw material are tested in the Analysis and Experimentation Laboratory, a very efficient structure for the fine-tuning of high-quality products conforming international norms.

CONCEPT

A rich collection of executive and middle-management seating that suggests a revival of classic forms and details typical of Poltrona Frau's craft tradition, for example the scrolls on the backrest and seat.

ポルトローナ・フラウ研究開発センター

1960年代後半、ポルトローナ・フラウは社内に研究開発部門を開設。高度なクラフツマンシップのノウハウを大切に保ちつつ、研究開発センターでは新しい素材、新しい製造技術を研究し、新たなフォルムを開発している。当グループはデザイン・設計部に高度な専門技術を持つ技術者を擁し、新しい発想を具現化するプロトタイプ部門の設備も極めて充実しているため、高品質で国際規格に適合する製品を生み出すのに役立っている。素材や製品をテストする分析・実験ラボの役割も担っている。

コンセプト

エグゼクティブや幹部のオフィス用高級コレクション。クラシックなフォルム、渦形装飾を始めとするディテールにポルトローナ・フラウならではの伝統的クラフツマンシップが際立つ。

POLTRONA FRAU R. & D.

20世紀60年代后期，Poltrona Frau 成立了内部研发部门。在保持专业制造工艺知识的同时，研发中心还专注于新材料、新建筑技术和新造型的研究。研发中心高度专业化的设计人员可利用配备精良的原型实验室，从而形成新的设计概念。产品和原材料在分析实验室进行试验，可对符合国际标准的高质量产品进行有效的精确调整。

理念

各种款式的高管和中级管理层座椅，充分体现了 Poltrona Frau 特有传统工艺的经典形式和细节，如靠背和座面的涡卷褶皱。

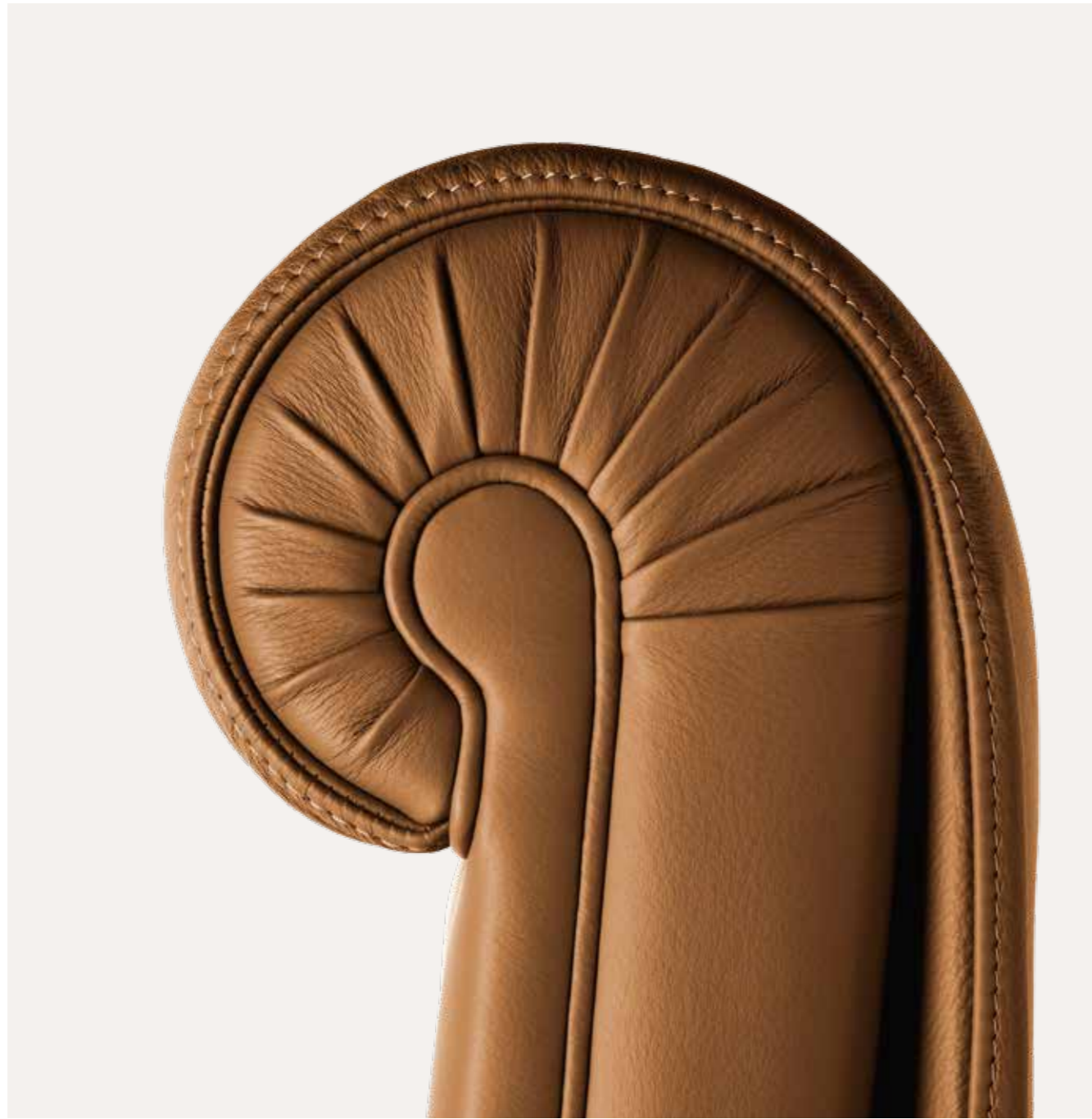

Forum ha la struttura portante in legno con terminale a voluta. Il rivestimento è in Pelle Frau® del Color System arricchito da una trapunta in pelle su sedile e schienale. Il basamento a 5 razze è disponibile in alluminio verniciato nero o lucido attrezzabile con ruote di vario tipo o scivoli.

Solid wood structure. A leather upholstered quilt gives to the back and to the seat a more elegant look. Five stars base available in black epoxy or polished aluminium finish on either castors (many types are available) or glides.

Forum のフレームはウッド製で、先端に渦形装飾が見られる。革張りはカラー・システムの Pelle Frau® ペッレ・フラウ®。座部と背もたれのレザーに特別なキルティングを施し、高級感が際立つ。主柱から脚が5本、ブラック塗装仕上げ又は光沢仕上げのアルミ製。種々のキャスター、又はグライダー・キャスター付。

实木框架结构。皮革套面配以精致的缝线，使得座椅和后背看起来更显高雅。五轮底座采用黑色环氧涂料或抛光铝饰面配有各种款型的滑轮或导轨。





Regolabili in altezza e rotabili su stesse, le versioni President, Executive e Managerial sono dotate anche di un meccanismo di oscillazione di schienale e sedile con blocchi intermedi. Nella President e Executive è opzionale l'estensione del poggiatesta e del sedile attraverso un dispositivo elettropneumatico. Le versioni Meeting e Meeting Large sono disponibili con un meccanismo di rotazione con ritorno nella posizione di partenza.

The President, Executive and Managerial versions are height adjustable, rotate, and are fitted with a turning mechanism for seat and backrest with lock-in positions. For the President and Executive versions there is an optional electro-pneumatic regulation of the lumbar area and seat. Fully rotating, the Meeting and Meeting Large versions can be also equipped with an automatic return rotation mechanism.

高さ調節可能で回転式、President、Executive、Managerial のモデルでは、背部と座部がリクライニング式で数段階調節可能。PresidentとExecutiveではオプションで腰部と座部の空気圧調節機能が付く。MeetingとMeeting Largeのモデルはオートリターン機能付。

总裁椅、行政椅和经理椅版本均可调节高度可旋转并配有旋转装置使座位和后背可锁定状态。总裁椅和行政椅版本另外可选腰部区域的电动气动调节装置。可自由旋转，会议椅和大会议椅版本也装备了自动还原旋转装置。

Forum President / Executive / Managerial / Meeting large / Meeting



Forum President

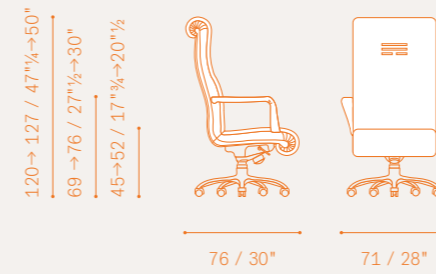

Forum Executive

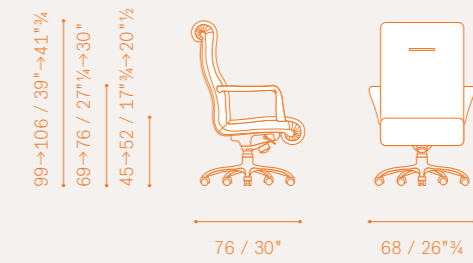

Forum Managerial — with or without armrests

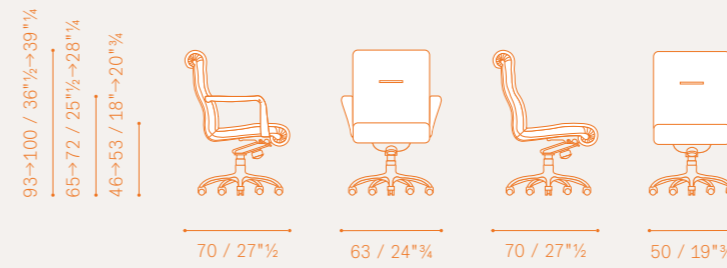

Forum Meeting Large

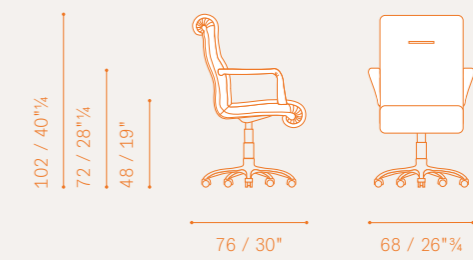

Forum — Finishings

Upholstery

— Pelle Frau® leather from the Color System

Base

— Aluminium in a black finish
— Polished aluminium

Supports

— Soft, self-braking "W" type castors — Hard, self-braking swivel castors
— Free-rolling soft castors — Free-rolling hard castors
— Swivel glides (2 cm lower height)

Forum President / Executive

— with Electro-pneumatic system — manual adjustments

Forum Meeting / Meeting Large

— with "Back to position mechanism" and swivel glides
— without "Back to position mechanism"

Forum Meeting — with or without armrests

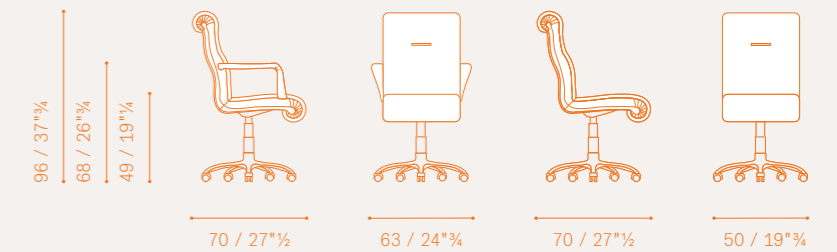

Emilio Ambasz

Brief



EMILIO AMBASZ

Nato in Argentina nel 1943, ha studiato alla Princeton University dove ha conseguito il Master in Architettura. Famoso per il suo pionierismo architettonico teso all'integrazione della natura con l'architettura, è stato soggetto di un'esposizione architettonica al Museo di Arte Moderna di New York nel 1989 ed alla Triennale di Milano, dove ha anche esposto i suoi disegni industriali. In possesso di numerosi brevetti industriali e meccanici, ha ricevuto il premio Compasso d'Oro nel 1981.

CONCEPT

Brief si distingue per la possibilità che schienale, sedile e braccioli offrono di adattarsi alle diverse misure antropometriche assecondando le svariate posture di ogni singolo utilizzatore.

EMILIO AMBASZ

Born in 1943 in Argentina, has a Master's Degree in Architecture from Princeton University. Renowned for his pioneering architecture integrating nature with architecture, he was the subject of an architectural exhibition at The Museum of Modern Art in New York in 1989, and at the Triennale di Milano, which also included his industrial designs. Mr. Ambasz holds a number of industrial and mechanical design patents. He was awarded the Compasso d'Oro prize in 1981.

CONCEPT

Brief is an innovative product with an anatomically-designed seat, backrest and armrests. Through a unique, synchronized adjustment system, it adapts to suit the size and height of each user, easily supporting the many different variations in posture.

エミリオ・アンバース

エミリオ・アンバースは 1943 年アルゼンチンに生まれる。プリンストン大学で建築学修士号を取得。建築におけるパイオニア的活動は有名で、自然と建築の融合を図る。1989 年にニューヨーク近代美術館で建築作品をテーマにした展覧会が開催され、ミラノのトリエンナーレではインダストリアル・デザインの作品も展示された。Ambasz アンバースはインダストリアル・デザインや機械設計の分野で数多くの特許を所有。1981 年に Compasso d'Oro コンパッソ・ドーロ賞を受賞。

EMILIO AMBASZ

コンセプト

Brief は背部、座部、肘掛を使用者の体型や姿勢に合わせて様々に調節できる画期的な製品。

于 1943 年出生于阿根廷，拥有普林斯顿大学建筑学硕士学位。他以前卫建筑集成风格而闻名。他于 1989 年杂纽约现代艺术博物馆举办了个人建筑展并参加了米兰三年展，展出了其工业设计作品。Ambasz 先生持有大量工业和机械设计专利。他于 1981 年获得 Compassod'Oro 奖。

理念

Brief 是一种创新解决方案，拥有符合人体工学设计的座面和靠背。通过其独特的同步调节系统，可适用于不同身形和身高的使用者们各种不同的坐姿。

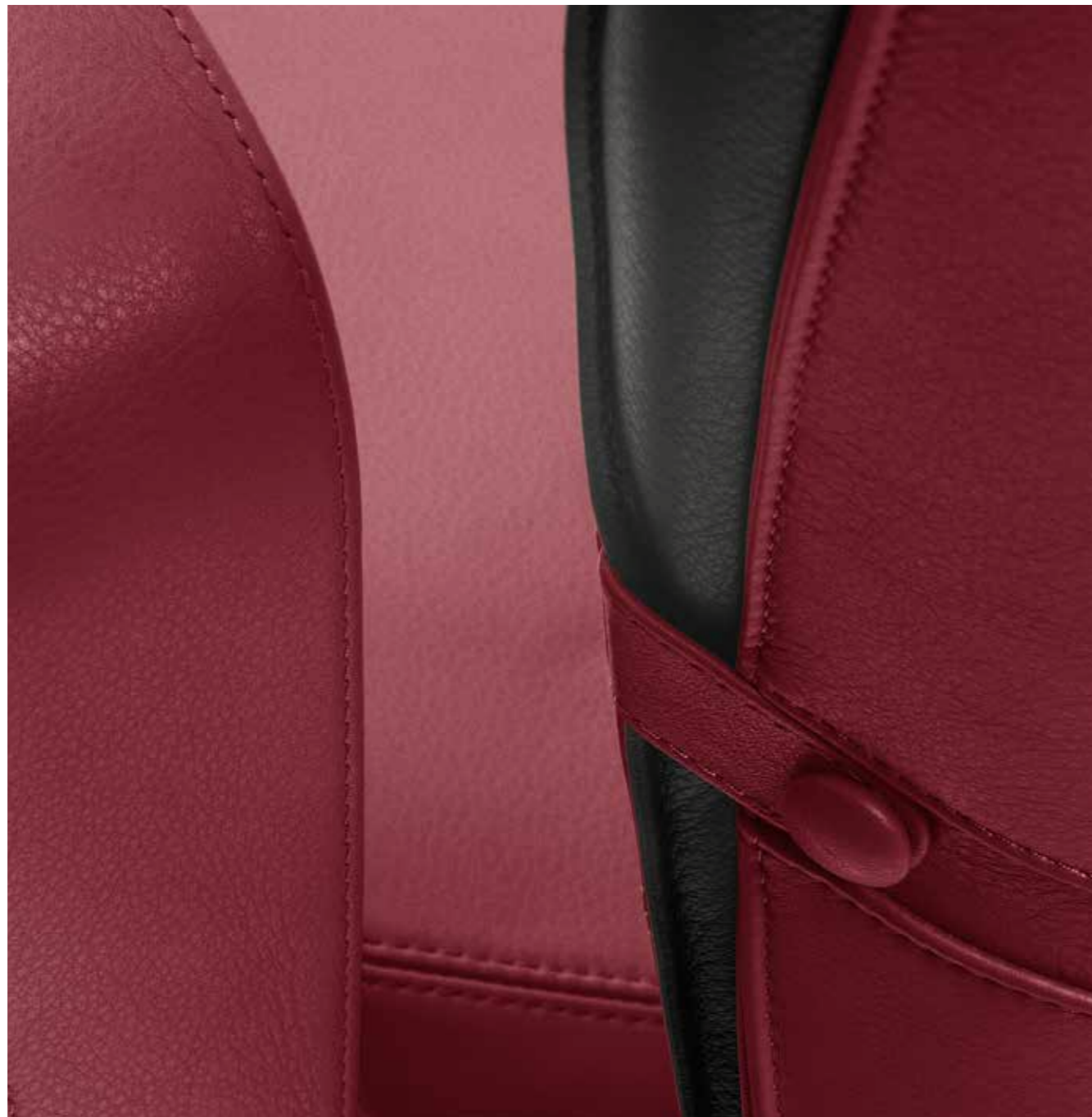

Brief ha la struttura in acciaio. Il rivestimento è in Pelle Frau® del Color System cucito a mano, anche in versione bicolore. Il basamento a 5 razze è disponibile in alluminio verniciato nero o lucido attrezzabile con ruote di vario tipo o scivoli.

Steel structure. Pelle Frau® from the Color System upholstery with hand-made stitching. It's also available in two-colored upholstery. Five stars base available in black epoxy or polished aluminium finish on either castors (many types are available) or glides.

構造はスチール製。革張りはカラーシステムの Pelle Frau® ペットレ・フラウ® を手作業で縫製する。バイカラーのバージョンもある。支柱から脚が5本、ブラック塗装又は光沢仕上げのアルミ製がある。様々なタイプのキャスター、又はグライダー・キャスター付が用意されている。

钢结构框架。套面采用 Pelle Frau® 色彩系列的皮革配以手工缝线，也可采用双色套面。五轮底座采用黑色环氧涂料或抛光铝饰面配有各种款型的滑轮或导轨。





Rotabili su se stesse, le poltrone Brief possono avere seduta, schienale e braccioli regolabili in altezza.

I modelli President ed Executive sono dotati di un sistema "Synchron" che consente un movimento oscillatorio di schienale e sedile con possibilità di parzializzazione dell'oscillazione. Le versioni Meeting e Meeting Large sono disponibili con un meccanismo di rotazione con ritorno nella posizione di partenza.

Fully rotating, the Brief armchairs can have seat, backrest and armrests height adjustment. The President and Executive versions are fitted with a "Synchron" mechanism with synchronized and reclining movement for seat and backrest. The Meeting and Meeting Large versions can be also equipped with an automatic return rotation mechanism.

Brief は回転式で座部、背部、肘掛の高さ調節機能付も可能。President、Executive は"シンクロン"システムにより、背部と座部のリクライニングを数段階に調節することができる。Meeting と Meeting Large はオートリターン機能付。

可自由旋转，Brief 扶手椅的座位，靠背，扶手高度均可调节。总裁椅和行政椅版本标准配置了 "Synchron" 装置使得座位和靠背能同步调节躺位。会议椅和大会议椅版本也装备了自动还原旋转装置。

Brief President / Executive / Managerial / Meeting Large / Meeting



Brief President — with adjustable or fixed armrests

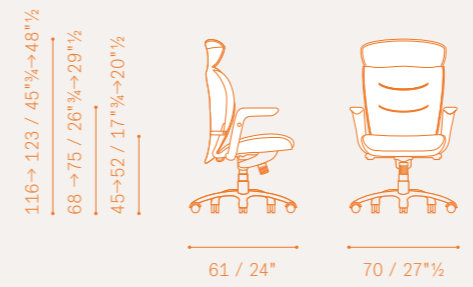

Brief Executive — with, without or adjustable armrests

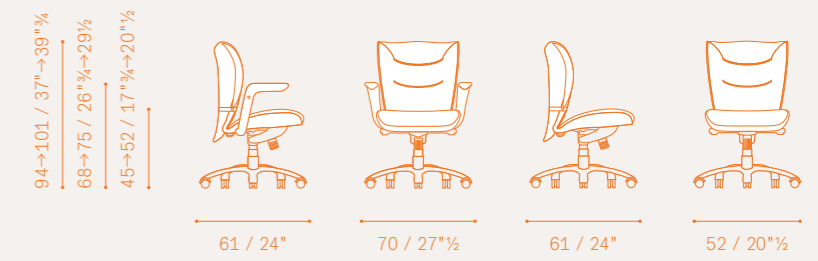

Brief Managerial — with, without or adjustable armrests

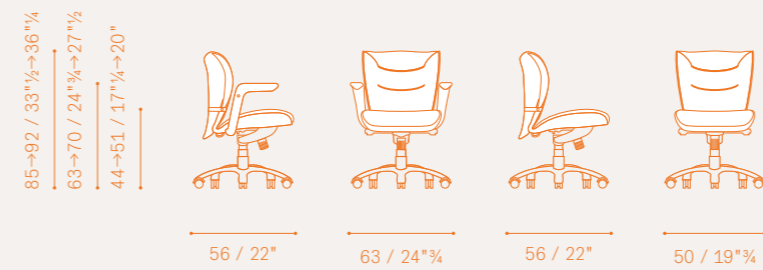

Brief Meeting Large — with or without armrests

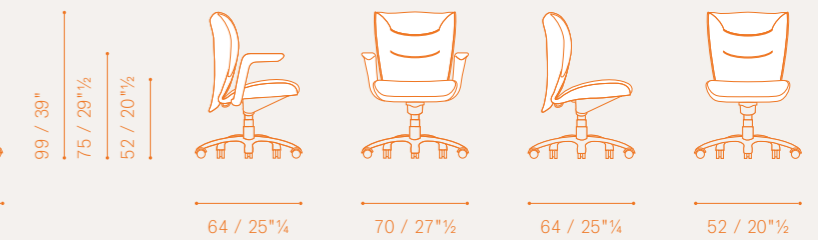

Brief — Finishings

Upholstery

- Pelle Frau® leather from the Color System
- Two-colored Pelle Frau® leather from the Color System

Base

- Aluminium in a black finish — Polished aluminium

Supports

- Soft, self-braking "W" type castors — Hard, self-braking swivel castors
- Free-rolling soft castors — Free-rolling hard castors
- Swivel glides (2cm lower height)

Brief President / Executive / Managerial

- with adjustable armrests — with fixed armrests
- (only for Executive and Managerial) without armrests

Brief Meeting / Meeting Large

- with fixed armrests — without armrests
- with "Back to position mechanism" — without "Back to position mechanism"

Brief Meeting — with or without armrests

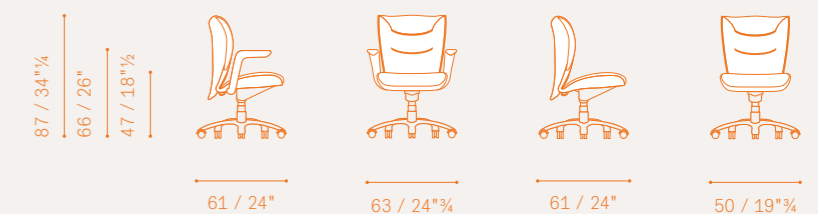

Poltrona Frau R. & D.

Oxford

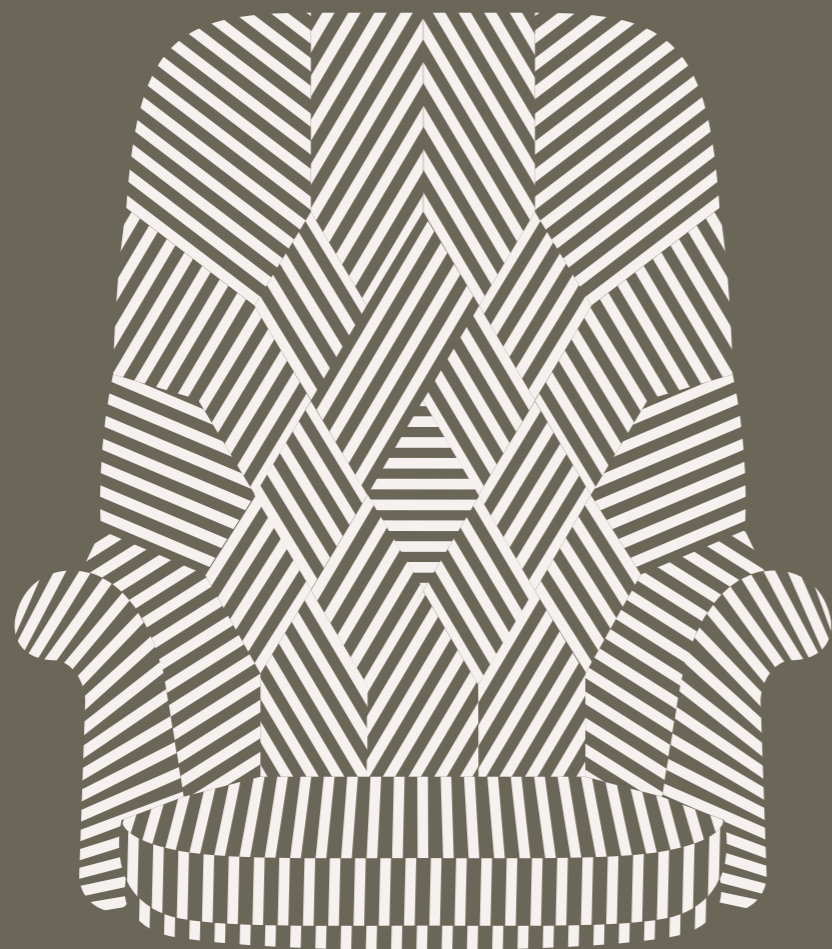

POLTRONA FRAU R. & D.

Dalla seconda metà degli anni sessanta Poltrona Frau ha creato una struttura interna che si occupa di ricerca e sviluppo. Ogni giorno, accanto alla salvaguardia del know-how di alta artigianalità, il Centro Ricerche e Sviluppo sperimenta nuovi materiali, nuove tecniche costruttive e realizza nuove forme. Il gruppo, che è formato da tecnici altamente specializzati nella progettazione, può contare su di un attrezzatissimo reparto di prototipazione nel quale dare forma alle nuove idee. Molto efficace, per la messa a punto di prodotti eccellenti nella qualità e conformi alle normative internazionali, è il Laboratorio di Analisi e Sperimentazione nel quale vengono testati i prodotti e le materie prime.

CONCEPT

Lavorazione "capitonée" per una poltrona d'ufficio pensata per chi ama le linee classiche e tradizionali. Design che riporta alla memoria le prestigiose sedute d'ufficio inglesi del primo Novecento.

POLTRONA FRAU R. & D.

Poltrona Frau, Second half of the 60. In the second half of the 1960s, Poltrona Frau created an internal structure to manage research and development. Whilst preserving the know-how of expert craftsmanship, the Centre for Research and Development experiments with new material, new building techniques and creates new forms. The highly specialised design technicians that make up the group benefit from a superbly equipped prototype laboratory, where they can give form to new ideas. Products and raw material are tested in the Analysis and Experimentation Laboratory, a very efficient structure for the fine-tuning of high-quality products conforming international norms.

CONCEPT

This quilted treated office armchair has been conceived for those who love classical, traditional lines. Its design calls to mind the high-prestige chairs typical of early 20th century English office furniture.

ポルトローナ・フラウ研究開発センター

1960年代後半、ポルトローナ・フラウは社内には研究開発部門を開設。高度なクラフツマンシップのノウハウを大切に保ちつつ、研究開発センターでは新しい素材、新しい製造技術を研究し、新たなフォルムを開発している。当グループはデザイン・設計部に高度な専門技術を持つ技術者を擁し、新しい発想を具現化するプロトタイプ部門の設備も極めて充実しているため、高品質で国際規格に適合する製品を生

み出すのに役立っている。素材や製品をテストする分析・実験ラボの役割も担っている。

コンセプト

クラシックな趣と伝統を愛する方のために、オフィス用アームチェアに“カピトネ”の手法を用いる。1900年代初頭の英国の格調高いオフィスを彷彿させるデザイン。

POLTRONA FRAU R. & D.

20世紀60年代后期，Poltrona Frau 成立了内部研发部门。在保持专业制造工艺知识的同时，研发中心还专注于新材料、新建筑技术和新造型的研究。研发中心高度专业化的设计人员可利用配备精良的原型实验室，从而形成新的设计概念。产品和原材料在分析实验室进行试验，可对符合国际标准的高质量产品进行有效的精确调整。

理念

这款办公扶手椅采用绗缝工艺，为那些热爱经典，崇尚传统的人士而生。它的设计让人回忆起 20 世纪早期英国办公家具中具有崇高声望的椅子的典型特征。



Girevoli, regolabili in altezza con molle a gas e basculanti con blocchi intermedi, le versioni Oxford President e Executive hanno il basamento a cinque razze disponibile in legno nocino d'America tinto noce medio, in alluminio verniciato con polvere epossidica nera o lucidato.

President and Executive versions are fully rotating, gas spring height adjustable and reclining with several fixed settings. The five-star base is made from American black walnut in a medium walnut stain, or from aluminium in a black epoxy or chrome finish.

回転式、ガス・シリンダーで高さ調節可能。リクライニングもでき、数段階の調節が可能。Oxford PresidentとExecutiveの5本脚付支柱はミディアム・ウォールナット・カラーのアメリカン・ウォールナット、もしくはブラックのエポキシ仕上げ又は光沢仕上げのアルミ製。

总裁椅和行政椅版本可自由旋转，气压式可调节高度装置，有几种固定的躺位设置可调。星形底座采用中度颜色的胡桃木染色的美国黑胡桃木，也可选择黑色涂层或抛光铝饰面。



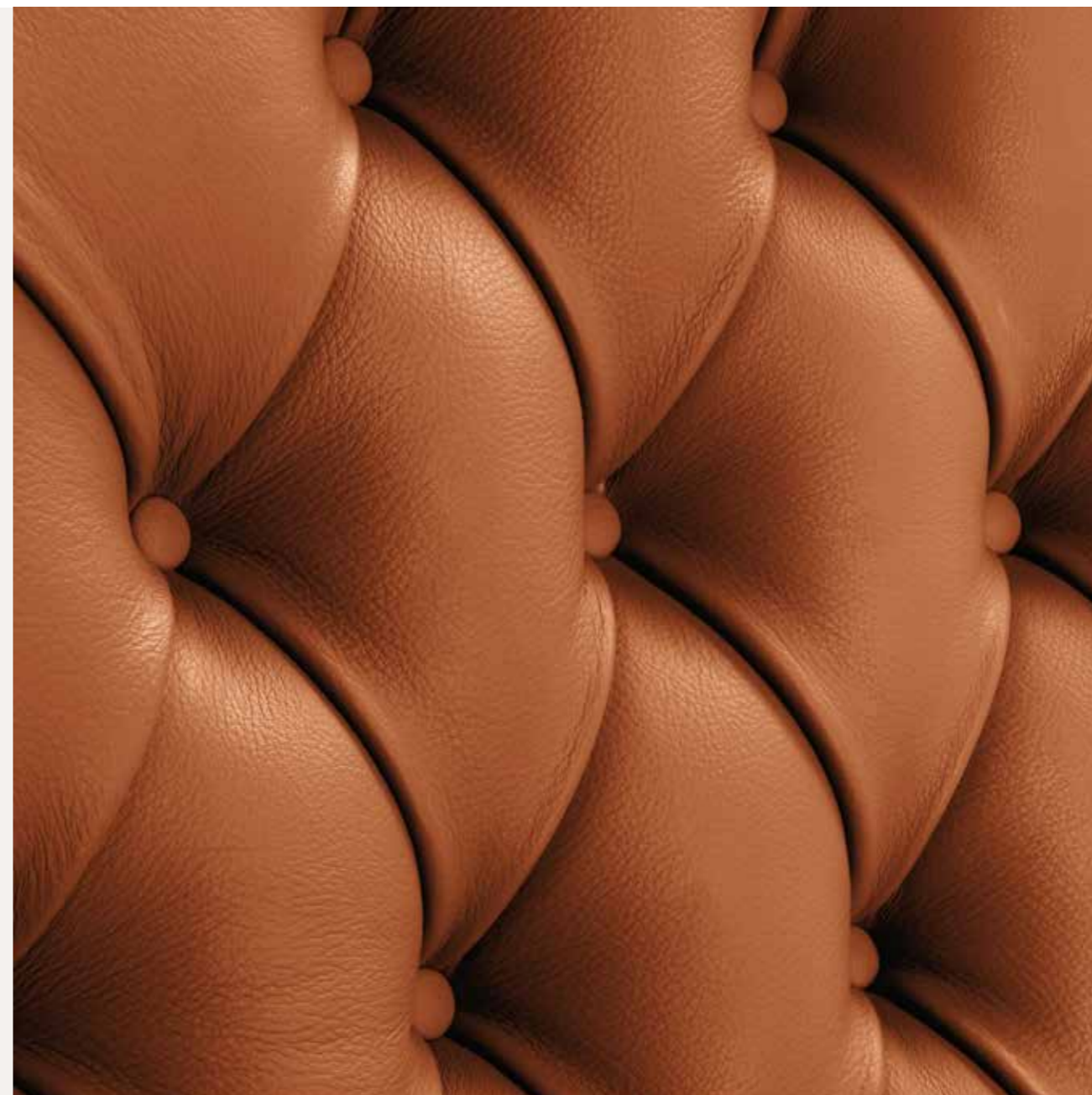

La struttura è realizzata in faggio stagionato con rivestimento in Pelle Frau® del Color System arricchito da lavorazione capitonnée eseguito a mano per la superficie interna. Nella versione Visitor le gambe sono fisse e sempre in Nocino d'America tinto noce medio.

Seasoned beechwood structure upholstered in Pelle Frau® leather from the Color System with hand-finished capitonnée quilting. Visitor version is only available with fixed, American black walnut in a medium walnut stained legs.

構造はシーズニングしたブナ材、革張りはカラー・システムの Pelle Frau® ペッレ・フラウ®、手作業で施すカピトネのボタン留めにより高級感が際立つ。Visitor の脚は常にミディアム・ウォールナット・カラーのアメリカン・ウォールナット。

该扶手椅框架采用风干榉木，套面可用 Pelle Frau® 色彩系统的皮革并配以手工缝线。访客版椅脚只适用中度颜色的胡桃木染色的美国黑胡桃木。

Oxford President / Executive / Visitor



Oxford President

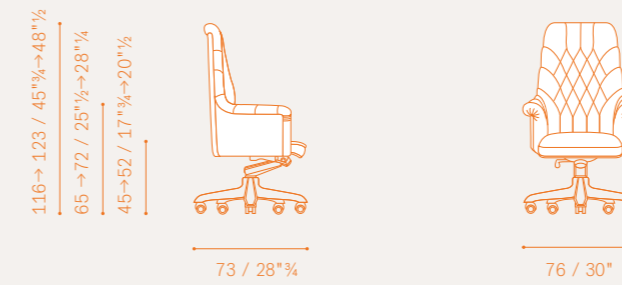

Oxford President aluminium

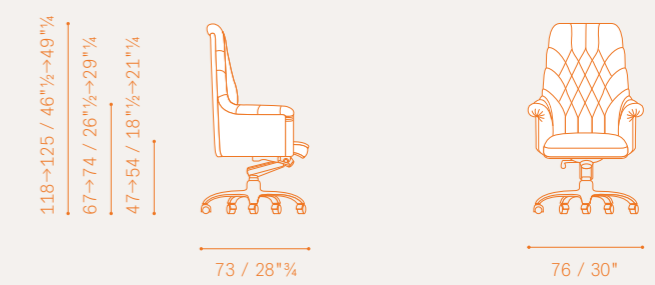

Oxford Executive

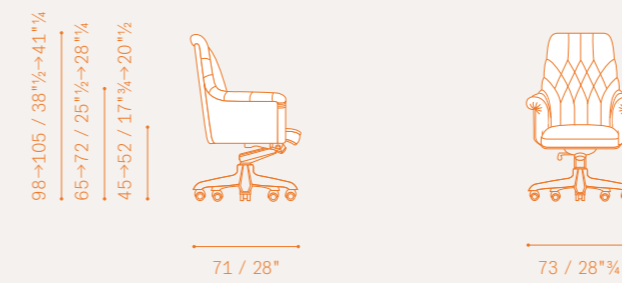

Oxford Executive aluminium

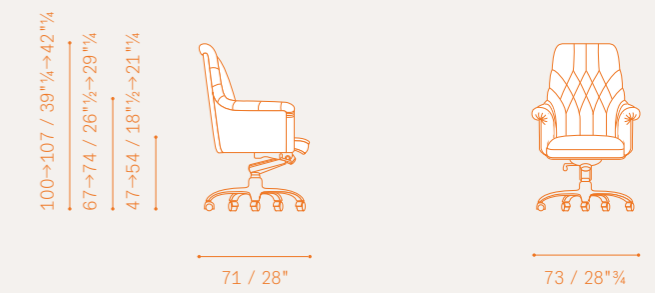

Oxford — Finishings

Upholstery

- Pelle Frau® leather from the Color System

Oxford President / Executive

Base

- American black walnut in a medium walnut stain
- Aluminium in a black finish
- Polished aluminium

Supports

- Soft, self-braking "W" type castors — Hard, self-braking swivel castors
- Free-rolling soft castors — Free-rolling hard castors
- Swivel glides (2 cm lower height)

Oxford Visitor

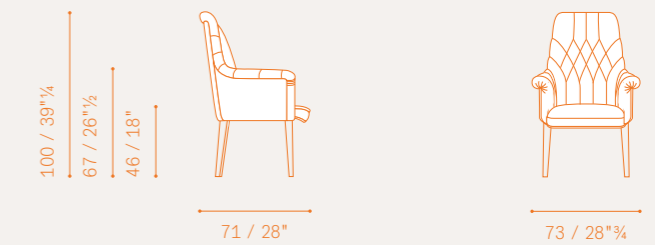

Tito
Agnoli

THF



Poltrone Conferenza — THF

Conference Armchairs — THF

会議場用アームチェア — THF

会议扶手椅 — THF



Una poltroncina dagli usi molteplici: seduta singola e serie di sedute in linea. L'imbottitura è in poliuretano ignifugo indeformabile. Il rivestimento è in Pelle Frau® del Color System o in tessuto fornito dal cliente. Un piccolo piano scrittoio può essere collocato a scomparsa nella gamba laterale. Disponibile con ruote o scivoli.

A multi-purpose armchair: as a single chair or row of seats. Non-deformable, fire-proof polyurethane padding. Upholstery is available in Pelle Frau® leather from the Color System or alternatively in the customer's own material. It can be equipped with a small writing top that disappears into a leg. Model available with castors or on glides.

様々な用途に使えるアームチェア: 一人掛けと並列がある。パッドの素材は難燃性形状安定ポリウレタン。Pelle Frau® Color System カラー・システムのペッレ・フラウ®で革張り又はクライアントから供給される生地を張る事も可能。メモ台の小さな天板は脚の中にたたみ込む事ができる。キャスター付かグライダー・キャスター付。

多功能扶手椅: 可作为单椅或成排座椅使用。填充为不变形防火聚氨酯。包括带有前单向和后旋转脚轮或导轨的款式。根据要求, 可配备写字板和连接系统。

THF 96

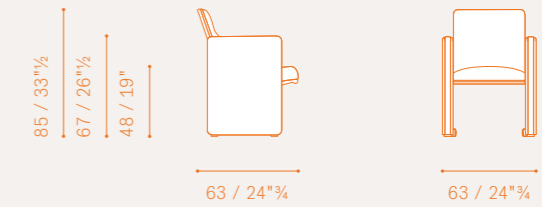

THF 98

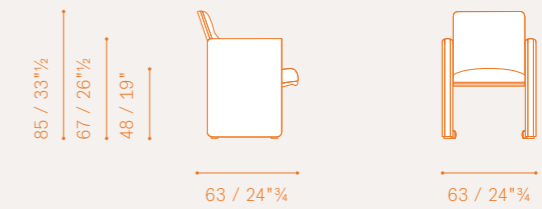

THF — Finishings

Upholstery

- Pelle Frau® leather from the Color System
- Client's Own Material (C.O.M.)

Supports

- Unidirectional castors
- Unidirectional front castors and swivel rear castors
- Glides

Fixing system

- without fixing system
- with fixing system

THF 98

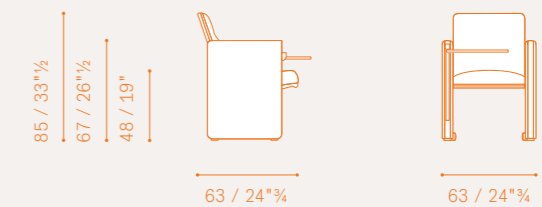

Mario
Marenco

Movie





La struttura è in tubolare di acciaio, verniciato nero opaco oppure cromato. Il rivestimento è in Pelle Frau® del Color System con finitura dei bordi con levigatura e tinteggiatura a mano. Posizionabile in file con sistema d'aggancio, è impilabile fino a un massimo di 8 poltroncine. Il piano-scrittura, in policarbonato, è estraibile con sistema di innesto a baionetta.

The frame is made of black or chrome-finish steel tubing. It's upholstered in Pelle Frau® leather from the Color System with edges hand-polished and painted. The writing tablet attached to the support structure is made of polycarbonate. The chairs are stackable up to maximum of 8 chairs. They can also be connected side-to-side on demand.

構造はマットのブラック塗装又はクロム仕上げのスチール製パイプ材。革張りは Pelle Frau® Color System カラー・システムのペツレ・フラウ®。縁の研磨と塗装は手作業で行う。連結システムにより並列が可能。8脚まで積み重ねられる。メモ台の小さな天板はポリカーボネート製で差し込み式の接合。

框架采用黑色或镀铬管状不锈钢。套面使用 Pelle Frau® 色彩系列的皮革，边缘采用手工打磨着色。支撑框架上连接的写字板用塑料制成。椅子可叠起堆放，最多可以叠8把。也可以根据需求横向连接组合。

Movie

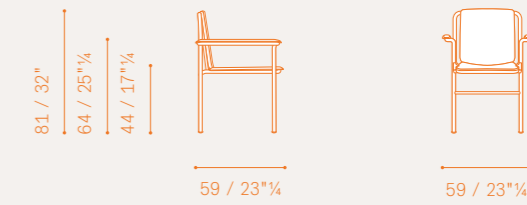

Movie with writing surface



Movie — Finishings

Structure

- Chrome finished
- Matt black finished

Accessories

- with writing surface
- without writing surface

Fixing system

- without fixing system
- with fixing system

Ring





Struttura di gambe e schienale in tubolare d'acciaio a profilo quadrato verniciato a polvere epossidica nero opaca o canna fucile. Il telaio della seduta è in pressofusione di alluminio. Maneggevole e facilmente impilabile, Ring è disponibile in Pelle Frau® del Color System o in tessuto fornito dal cliente.

Legs and backrest structure is in square tubular steel with epoxy paint in matt black or gun-metal grey finishes. The seat frame is moulded in pressure die-cast aluminium. It is easy to handle and stackable. Ring is available with Pelle Frau® from the Color System upholstery or in the customer's own material.

脚と背部の構造はスチール製で四角い断面のパイプ材にマットなブラックもしくはガン・メタルのエポキシ仕上げ。座部のフレームはアルミのプレス鋳造。扱い易く、積み重ねも可能。Ring は Pelle Frau® Color System カラー・システムのペルレ・フラウ®で革張り又はクライアントから供給される生地を張る事も可能。

椅腿和后背框架是方管状钢材，涂有哑光黑色或青铜灰色环氧涂料。座椅框架是用压铸铝铸造而成。它易移动，可叠起堆放。Ring 的套面可使用 Pelle Frau® 色彩系列的皮革或客人指定材料。

Ring Chair — Pelle Frau® SC

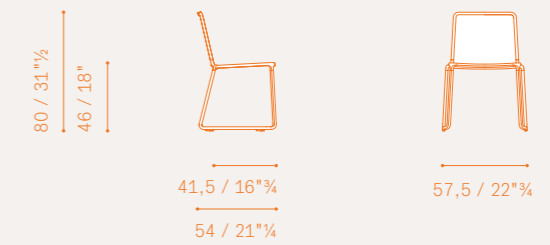

Ring — Finishings

Upholstery

- Pelle Frau® leather from the Color System
- Client's Own Material (C.O.M.)

Structure

- Matt black finished
- Gun-metal grey finish

Ego





La struttura portante è realizzata in acciaio con imbottitura in poliuretano espanso ottenuto da stampo. Il molleggio della seduta è ottenuto con cinghie elastiche. La poltroncina, montata su ruote, è rivestita in Pelle Frau® del Color System. Ego è caratterizzata da una maniglia sul retro dello schienale che rende più agevole lo spostamento.

Moulded steel structure with polyurethane foam padding. Seat suspension with elastic belts. Ego is upholstered in Pelle Frau® leather from Color System and It's fitted out with four unexposed castors. A handle, inserted in the back, under the headrest, allows for easy movement of the armchair.

スチール製の支柱にモールド成形のポリウレタン・フォームをパッドとして使用。座部のサスペンションはイラスティック・ベルト。Pelle Frau® Color System カラー・システムのパッセル・フラウ® で革張りしたこのアームチェアはキャスターの上に乗っている。Ego の背部の後ろには取っ手があり、運ぶのに便利。

高分子泡沫填充配以铸钢结构。座位倚靠弹力细带支撑悬浮。Ego 套面可使用 Pelle Frau® 色彩系统的皮革。配备 4 个隐藏式脚轮。

Ego Meeting Chair

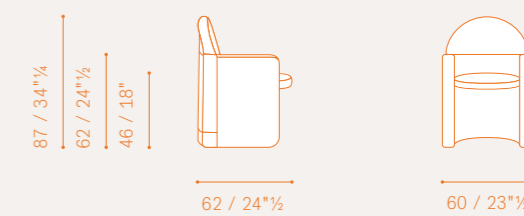

Ego — Finishings

- Rear supports**
- Soft, self-braking swivel castors
 - Hard, self-braking swivel castors
 - Free-rolling soft castors
 - Free-rolling hard castors

Lella and Massimo
Vignelli

Onda





La struttura di sedile e schienale è realizzata in acciaio mentre quella dei fianchi è in legno. L'imbottitura è realizzata in poliuretano espanso ottenuta da stampo. Il rivestimento è in Pelle Frau® del Color System. Le ruote di serie sono anteriormente unidirezionali e posteriormente piroettanti autofrenanti morbide, a richiesta sono disponibili ruote autofrenanti dure, libere dure o morbide o scivoli in gomma.

Steel structure for seat and backrest and wooden sides structure.
Moulded polyurethane foam padding.
Upholstered in Pelle Frau® leather from the Color System, Onda Bridge is available as standard with two front castors with back-forth movement and two self-braking swivel rear castors in a soft-surface finish. On request also available in a hard-surface finish, and with or without self-braking mechanism, or on rubber glides.

座部と背部の構造はスチール製、両サイドはウッド。パッドにはモールド成形のポリウレタン・フォームを使用。革張りは Pelle Frau® Color System カラー・システムのペッレ・フラウ®。フロントのキャスターは前後方向のみ、リアは車輪の表面がソフト・タイプでセルフ・ブレーキ機能付回転式キャスターが基本。リクエストに応じて、表面がハード・タイプのセルフ・ブレーキ機能付、ブレーキ機能無しのハード又はソフト、ラバー製グライダー・キャスター付も可能。

座位和后背结构为钢制，扶手边框为木结构。填充物为模制聚氨酯海绵。套面可使用 Pelle Frau® 色彩系统的皮革。Onda Bridge 配准配置可来回移动的两个前轮和两个独立旋转可刹车软面后轮。根据需求也可以改成硬面后轮不配刹车装置或者是橡皮垫。

Onda — glides

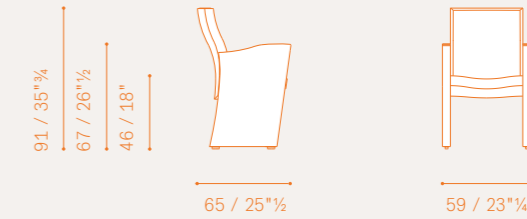

Onda — castors

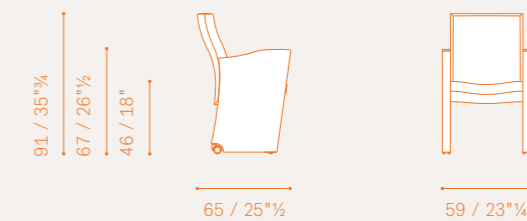

Onda — Finishings

Upholstery

— Pelle Frau® leather from the Color System

Supports

- Unidirectional front castors and soft, self-braking swivel rear castors
- Unidirectional front castors and hard, self-braking swivel rear castors
- Unidirectional front castors and free-rolling soft rear castors
- Unidirectional front castors and free-rolling hard rear castors
- Glides

Chancellor Conference





Chancellor Conference con base a slitta completa la famiglia di poltrone ufficio Chancellor. La base d'appoggio è in tubolare d'acciaio cromato o verniciato colore grigio scuro. Il rivestimento è in Pelle Frau® del Color System. I braccioli, nella versione che li prevede, sono in tubolare di acciaio rivestiti in pelle e rifiniti con attacchi terminali alla struttura in alluminio lucido o verniciati grigio scuro.

Chancellor Conference with sled base completes the range of Chancellor office armchairs. The structure is in moulded polyurethane foam with a metal insert. The tubular steel resting base is available in a polished chrome plate or in a dark grey finish with plastic feet. Upholstered in Pelle Frau® leather from the Color System. The armrests, in the armchair version, are in tubular steel upholstered in leather and finished with ends attached to the structure in a polished aluminium or dark grey finish.

Chancellor のオフィス用アームチェアのシリーズを締めくくることが滑り座のついた Chancellor Conference。支柱はクロム仕上げ又はダークグレー塗装仕上げのスチール製パイプ材。革張りは Pelle Frau® Color System カラー・システムのペッレ・フラウ®。肘掛はスチール製パイプ材の革張り、端は光沢仕上げ又はダークグレー塗装仕上げのアルミ製。

Chancellor Conference, 雪橇式底座，完善了 Chancellor 办公扶手椅系列。框架由金属制成，包裹聚氨酯泡沫。管状钢制支撑底座可采用抛光镀铬金属板或是深灰色涂层塑料脚。套面可使用 Pelle Frau® 色彩系统的皮革。在扶手椅版本中，扶手倚靠部分采用管状钢制结构配以皮革软包，尽头处的金属连接采用抛光铝或深灰涂层。

Chancellor Conference with armrests

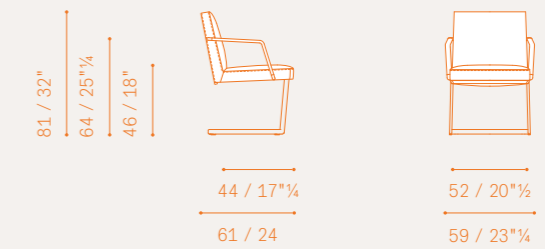

Chancellor Conference

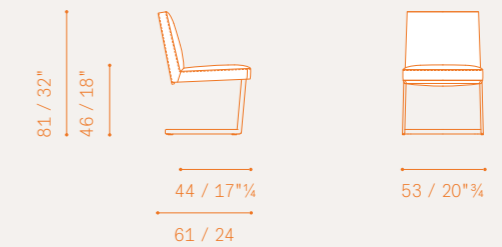

Chancellor Conference — Finishings

Upholstery

— Pelle Frau® leather from the Color System

Base

— Metal in a dark grey finish
— Chrome finished metal

Stitching

— In matching tones thread
— With a contrast thread

Poltrona Frau
R. & D.

Forum Bridge





Forum Bridge completa la famiglia di poltrone ufficio Forum. La struttura portante è in legno con imbottitura in poliuretano espanso. La poltroncina, fornita su ruote di diverso tipo o scivoli, ha il rivestimento in Pelle Frau® del Color System.

Forum Bridge completes the range of Forum office armchairs. Solid wood structure with polyurethane foam padding. Bridge armchair is mounted on castors, available in different types, or on rubber slides Upholstery is available in Pelle Frau® leather from Color Systems.

Forum Bridge は Forum のオフィス用アームチェアのシリーズを締めくくる。ウツの支柱にポリウレタン・フォームのパッド。様々なタイプのキャスターやグライダー・キャスター付が用意されている。革張りは Pelle Frau® Color System。カラー・システムのペッレ・フラウ®。

Forum Bridge 完善了 Forum 办公扶手椅系列产品。实木框架配以聚氨酯泡沫填充物。Bridge 扶手椅增加了不同版本的轮子或是橡皮圈。套面可使用 Pelle Frau® 色彩系统的皮革。

Forum Bridge — glides

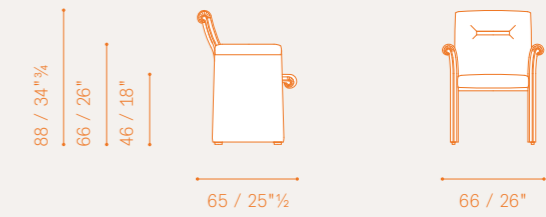

Forum Bridge — castors

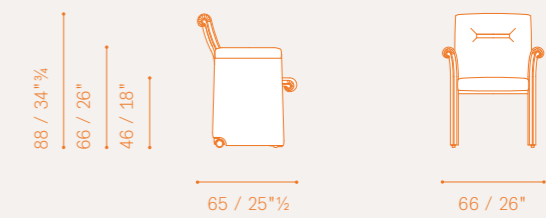

Forum — Finishings

Upholstery

— Pelle Frau® leather from the Color System

Supports

- Unidirectional front castors and soft, self-braking swivel rear castors
- Unidirectional front castors and hard, self-braking swivel rear castors
- Unidirectional front castors and free-rolling soft rear castors
- Unidirectional front castors and free-rolling hard rear castors
- Glides

Pelle Frau® Color System Frau® (SC)

PELLE FRAU®

Ingrediente principe del suo successo, la pelle rappresenta per Poltrona Frau molto più di una semplice materia di progetto: pelle e cuoio sono "icone materiali" da utilizzare in quanto simbolo di eleganza, prestigio, qualità. Per dare alla pelle un volto attuale, Poltrona Frau ha sviluppato nel tempo processi esclusivi di lavorazione delle pelli bovine. Solo pelli in grado di garantire caratteristiche di impermeabilità, traspirazione, resistenza allo sfregamento e alle macchie, vengono definite Pelle Frau®.

COLOR SYSTEM FRAU® (SC)

Pelle Frau® significa anche colore, come le tonalità progettate del Color System: un'ampia varietà di nuance che permette di creare abbinamenti armonici delle tinte sia fra arredi diversi che all'interno dello stesso oggetto. Una particolare ricerca tecnica e la notevole esperienza di Poltrona Frau hanno permesso un ideale equilibrio tra il materiale naturale e il trattamento della superficie in fase di rifinitura. Interessante sotto il profilo organolettico, la Pelle Frau® del Color System con il tempo acquista in eleganza.

PELLE FRAU® LEATHER

Leather is much more than a valuable design material for Poltrona Frau: a key ingredient in its success, leather is perceived as a veritable "icon", a material symbolizing elegance, prestige and quality. To give the leather an up-to-date image, over the years Poltrona Frau has developed exclusive techniques for the treatment of calf skins. Only skins that ensure excellent properties in terms of impermeability, breathability, resistance to rubbing and stains are deemed eligible to go by the name of Pelle Frau® Leather.

COLOR SYSTEM FRAU® (SC)

Pelle Frau® leather means colour, too, like the planned colours of the Color System: a wide variety of different nuances of colours. This makes it possible to harmoniously combine the shades both among the different pieces of furniture and of the same object. Poltrona Frau's special technical research and considerable experience have allowed to achieve the perfect balance between the natural material and surface treatment in the finishing phase. Interesting in organoleptic terms, for its high-resistance features and for its excellent response during use and care, Pelle Frau® leather of the Color System gains in elegance over time.

PELLE FRAU® ペッレフラウ®

コレクションの成功に重要な役割を果たした素材です。Poltrona Frau ポルトローナ・フラウ社にとって、革は単なるプロジェクトの素材以上の存在、エレガンス、格調、品質を象徴する「究極の素材」といえるでしょう。革に現代的な特徴を与えるために、Poltrona Frau ポルトローナ・フラウ社は時間をかけて独自の牛革加工プロセスを開発してきました。防水性、通気性、摩擦への耐久性、汚れ難さを兼ね備えた革だけに、Pelle Frau® ペッレフラウ®の称号が許されるのです。

COLOR SYSTEM FRAU® (SC) カラーシステムフラウレザー®

カラーシステムフラウレザーのカラーチャートが示す通り、Pelle Frau® ペッレフラウ®の特徴は彩りでもあります。豊富な色彩のニュアンスは他のインテリアとの調和のとれたコーディネートや製品自体の色調の調和を生みます。Poltrona Frau ポルトローナ・フラウ社は特別な技術開発と長年の経験を活かして、革の仕上げの段階で天然皮革に施す表面の加工の理想的なバランスを見出しました。Pelle Frau® ペッレフラウ®のColor System Frau® カラーシステムフラウレザーは、時を重ねるほどそのエレガンスを増して行きます。

PELLE FRAU® 皮革

皮革不仅仅是 Poltrona Frau 所采用的有价值的材料，同时是其成功的关键因素，皮革被认为是一种象征优雅、高贵和品质的材料。为使皮革具有与时俱进的形象，百年来 Poltrona Frau 开发了独特的牛皮处理技术。只有具有 Pelle Frau® 商标的皮革才能保证在渗透性、透气性、耐磨和防污上具有优越的特性。

COLOR SYSTEM FRAU® SC SC 皮革系列

Pelle Frau® 皮革也意味着色彩，正如 Color System 系列中所展现出的色彩：色彩的细微差别和多样性。这使得在不同的产品乃至于同一个产品上，不同的色调组合都可以达到和谐自然。Poltrona Frau 的特殊工艺研究和现有经验相结合使得天然原材料和表面处理后的饰面之间达到完美的平衡。在持久的皮革特性和使用及保养的优越反馈基础上，在感官上，Pelle Frau® SC 皮革时间越久越感到典雅。



Pelle Frau® Saddle

CUOIO SADDLE

All'interno di una casa o di un ufficio il cuoio è soggetto a sollecitazioni d'uso quotidiano e a sbalzi di temperatura. Poltrona Frau ha eseguito scrupolosi test prima di arrivare alla definizione del cuoio Saddle. Stabilità dimensionale, qualità e durata costanti nel tempo sono le caratteristiche principali. La base del materiale è una pelle di bovino adulto di provenienza europea lavorata con tecniche naturali e finita con tintura passante per limitare eventuali danni derivanti da graffi accidentali. Il cuoio Saddle è stabile alla luce e ha una buona resistenza alle macchie.

SADDLE LEATHER

Both in the house and office, leather is subject to the requirements of daily use and temperature changes. Poltrona Frau carried out scrupulous testing before reaching a definition of Saddle leather. Dimensional stability has been considered essential, together with constant, durable quality. The base of the material is European adult bovine skin, worked with natural techniques and dyed-through, in order to limit damage from accidental scratches. Saddle leather is stable in light, and resists stains well.

クオイオ・サドル

住宅内やオフィスの環境に於いて、なめし革は日々の使用による消耗や気温の変化に影響されます。ポルトローナ・フラウ Poltrona Frau はそうした環境に対応のための入念なテストを重ね、クオイオ・サドルを開発しました。伸び縮みが少なく安定性に優れ、経年劣化に強く耐久性に富んでいることが本素材の主な特徴です。本素材はヨーロッパ産成牛の原皮をナチュラルな技法で加工し、皮革層全体に深く染色することにより、万一使用中に小さな傷がついたとしても、それが目立ちにくい加工を施してあります。サドル・レザーは耐光性があり、シミがつきにくくなっています。

SADDLE 同时适用于家居空间和办公空间

该皮革能适应每日的使用需求和温度变化。Poltrona Frau 在推出一款 Saddle 皮革前，会进行严格谨慎的测试。皮革弹性的稳定性是最基本的要素，与持久耐用的质量同等重要。原材料采用欧洲成年牛皮，配以自然技术和织染，为了减少意外的划痕。Saddle 皮革在光照下不易褪色且抗污效果极佳。



The Office Credits

CONTACTS

Poltrona Frau S.p.A
Via Sandro Pertini, 22
62029 Tolentino MC Italy

Tel. +39 0733 909.1
Fax +39 0733 971600

www.poltronafrau.com

CREDITS

Art direction / Graphic design
studio FM milano

Photography
Riccardo Bianchi

Adriano Brusaferrì
12→31, 72→79, 106→113, 134→137,
157, 165, 173, 181, 189, 197

Styling
Studio Salaris

Printing
Grafiche Martintype



© POLTRONA FRAU 2015

Poltrona Frau reserves the right to modify the products and the components in this catalogue, without any prior notice. Company with certified Quality Management System in accordance with ISO 9001, certified Environmental Management System in accordance with ISO 14001 and certified Occupational Health and Safety Management System in accordance with BS OHSAS 18001

Company subject to management and co-ordination of Haworth Italy Holding S.r.l